

PRO-FORM® CrossWalk Advanced CR

Model No. PFTL61931

Serial No. _____

Write the serial number in the space above for future reference.

Serial Number Decal

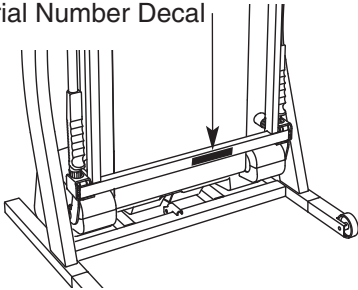

USER'S MANUAL

QUESTIONS?

If you have questions, or if there are missing parts, we will guarantee complete satisfaction through direct assistance from our factory.

TO AVOID DELAYS, PLEASE CALL DIRECT TO OUR TOLL-FREE CUSTOMER HOT LINE.
The trained technicians on our Customer Hot Line will provide immediate assistance, free of charge to you.

CUSTOMER HOT LINE:
1-888-533-1333
Mon.-Fri., 6 a.m.-6 p.m. MST

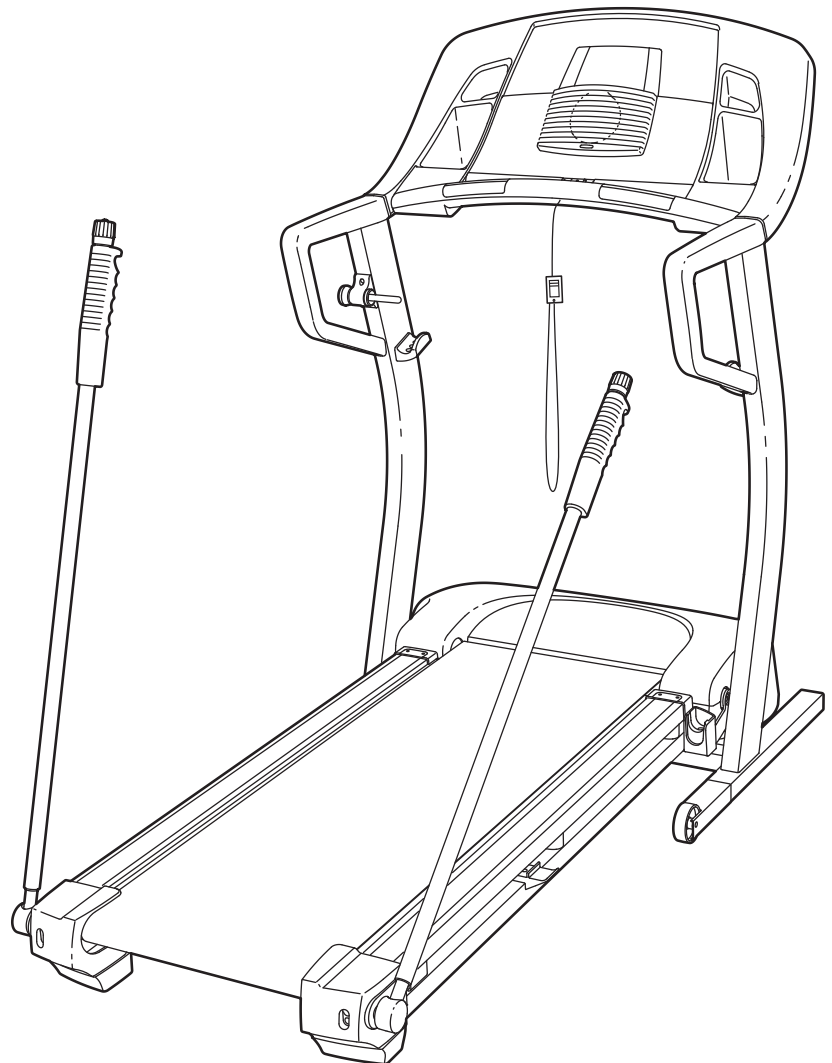

CAUTION

Read all precautions and instructions in this manual before using this equipment. Save this manual for future reference.



Visit our website at

www.proform.com

*new products, prizes,
fitness tips, and much more!*

PRO-FORM CrossWalk Advanced CR

TABLE OF CONTENTS

IMPORTANT PRECAUTIONS	3
BEFORE YOU BEGIN	5
ASSEMBLY AND PART IDENTIFICATION CHART	6
TREADMILL OPERATION	10
HOW TO FOLD AND MOVE THE TREADMILL	25
TROUBLESHOOTING	27
EXERCISE GUIDELINES	29
PART LIST	30
HOW TO ORDER REPLACEMENT PARTS	Back Cover
LIMITED WARRANTY	Back Cover

Note: An EXPLODED DRAWING is attached in the center of this manual.

IMPORTANT PRECAUTIONS

⚠ WARNING: To reduce the risk of burns, fire, electric shock, or injury to persons, read the following important precautions and information before operating the treadmill.

1. It is the responsibility of the owner to ensure that all users of this treadmill are adequately informed of all warnings and precautions.
2. Use the treadmill only as described in this manual.
3. Place the treadmill on a level surface, with at least eight feet of clearance behind it and two feet on each side. Do not place the treadmill on any surface that blocks air openings. To protect the floor or carpet from damage, place a mat under the treadmill.
4. Keep the treadmill indoors, away from moisture and dust. Do not put the treadmill in a garage or covered patio, or near water.
5. Do not operate the treadmill where aerosol products are used or oxygen is administered.
6. Keep children under the age of 12 and pets away from the treadmill at all times.
7. The treadmill should not be used by persons weighing more than 250 pounds. Never allow more than one person on the treadmill at a time.
8. Wear appropriate exercise clothes when using the treadmill. Do not wear loose clothes that could become caught in the treadmill. Athletic support clothes are recommended for both men and women. *Always wear athletic shoes. Never use the treadmill with bare feet, wearing only stockings, or in sandals.*
9. When connecting the power cord (see page 10), plug the power cord into a surge suppressor (not included) and plug the surge suppressor into a grounded circuit capable of carrying 15 or more amps. No other appliance should be on the same circuit. Do not use an extension cord.
10. Use only a single-outlet surge suppressor that meets all of the specifications described on page 10. To purchase a surge suppressor, see your local PROFORM dealer or call 1-888-533-1333 and order part number 146148.
11. Failure to use a properly functioning surge suppressor could result in damage to the control system of the treadmill. If the control system is damaged, the walking belt may change speed or stop unexpectedly, which may result in a fall and serious injury.
12. Keep the power cord and the surge suppressor away from heated surfaces.
13. Never move the walking belt while the power is turned off. Do not operate the treadmill if the power cord or plug is damaged, or if the treadmill is not working properly. (See **BEFORE YOU BEGIN** on page 5 if the treadmill is not working properly.)
14. Never start the treadmill while you are standing on the walking belt. Always hold the handrails or the upper body arms while using the treadmill.
15. The treadmill is capable of high speeds. Adjust the speed in small increments to avoid sudden jumps in speed.
16. The pulse sensor is not a medical device. Various factors, including the user's movement, may affect the accuracy of heart rate readings. The pulse sensor is intended only as an exercise aid in determining heart rate trends in general.
17. Never leave the treadmill unattended while it is running. Always remove the key, unplug the power cord, and move the reset/off circuit breaker to the off position when the treadmill is not in use. (See the drawing on page 5 for the location of the circuit breaker.)
18. Do not attempt to raise, lower, or move the treadmill until it is properly assembled. (See **ASSEMBLY** on page 6, and **HOW TO FOLD AND MOVE THE TREADMILL** on page 25.) You must be able to safely lift 45 pounds (20 kg) to raise, lower, or move the treadmill.
19. When folding or moving the treadmill, make sure that the storage latch is fully closed.

20. When using iFIT.com CDs and videos, an electronic “chirping” sound will alert you when the speed of the treadmill is about to change. Always listen for the “chirp” and be prepared for speed changes. In some instances, the speed may change before the personal trainer describes the change.

21. When using iFIT.com CDs and videos, you can manually override the speed setting at any time by pressing the speed buttons. However, when the next “chirp” is heard, the speed will change to the next settings for the CD or video program.

22. Always remove iFIT.com CDs and videos from your CD player or VCR when you are not using them.

23. Inspect and properly tighten all parts of the treadmill every three months.

24. Never drop or insert any object into any opening.

25. **DANGER:** Always unplug the power cord immediately after use, before cleaning the treadmill, and before performing the maintenance and adjustment procedures described in this manual. Never remove the motor hood unless instructed to do so by an authorized service representative. Servicing other than the procedures in this manual should be performed by an authorized service representative only.

26. The treadmill is intended for in-home use only. Do not use the treadmill in any commercial, rental, or institutional setting.

⚠ WARNING: Before beginning this or any exercise program, consult your physician. This is especially important for persons over the age of 35 or persons with pre-existing health problems. Read all instructions before using. ICON assumes no responsibility for personal injury or property damage sustained by or through the use of this product.

SAVE THESE INSTRUCTIONS

The decals shown below have been placed on your treadmill. If a decal is missing or illegible, please call our Customer Service Department toll-free at 1-888-533-1333 to order a free replacement decal. Apply the decal in the location shown. Note: The decals are not shown actual size.

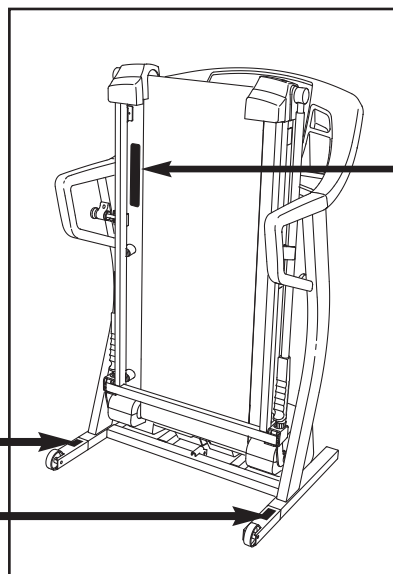

BEFORE YOU BEGIN

Congratulations for purchasing the PROFORM® CROSSWALK ADVANCED CR treadmill. The CROSSWALK ADVANCED CR treadmill offers an impressive array of features to help you achieve your fitness goals in the convenience of your home. From the advanced console to the cushioned walking platform, the CROSSWALK ADVANCED CR treadmill is designed to make each workout more effective and enjoyable. And when you're not exercising, the treadmill can be folded away, taking less than half the floor space of conventional treadmills.

using the treadmill. If you have questions after reading this manual, call our Customer Service Department toll-free at 1-888-533-1333, Monday through Friday, 6 a.m. until 6 p.m. Mountain Time (excluding holidays). To help us assist you, please note the product model number and serial number before calling. The model number is PFTL61931. The serial number can be found on a decal attached to the treadmill (see the front cover of this manual for the location).

Before reading further, please familiarize yourself with the parts that are labeled in the drawing below.

For your benefit, read this manual carefully before

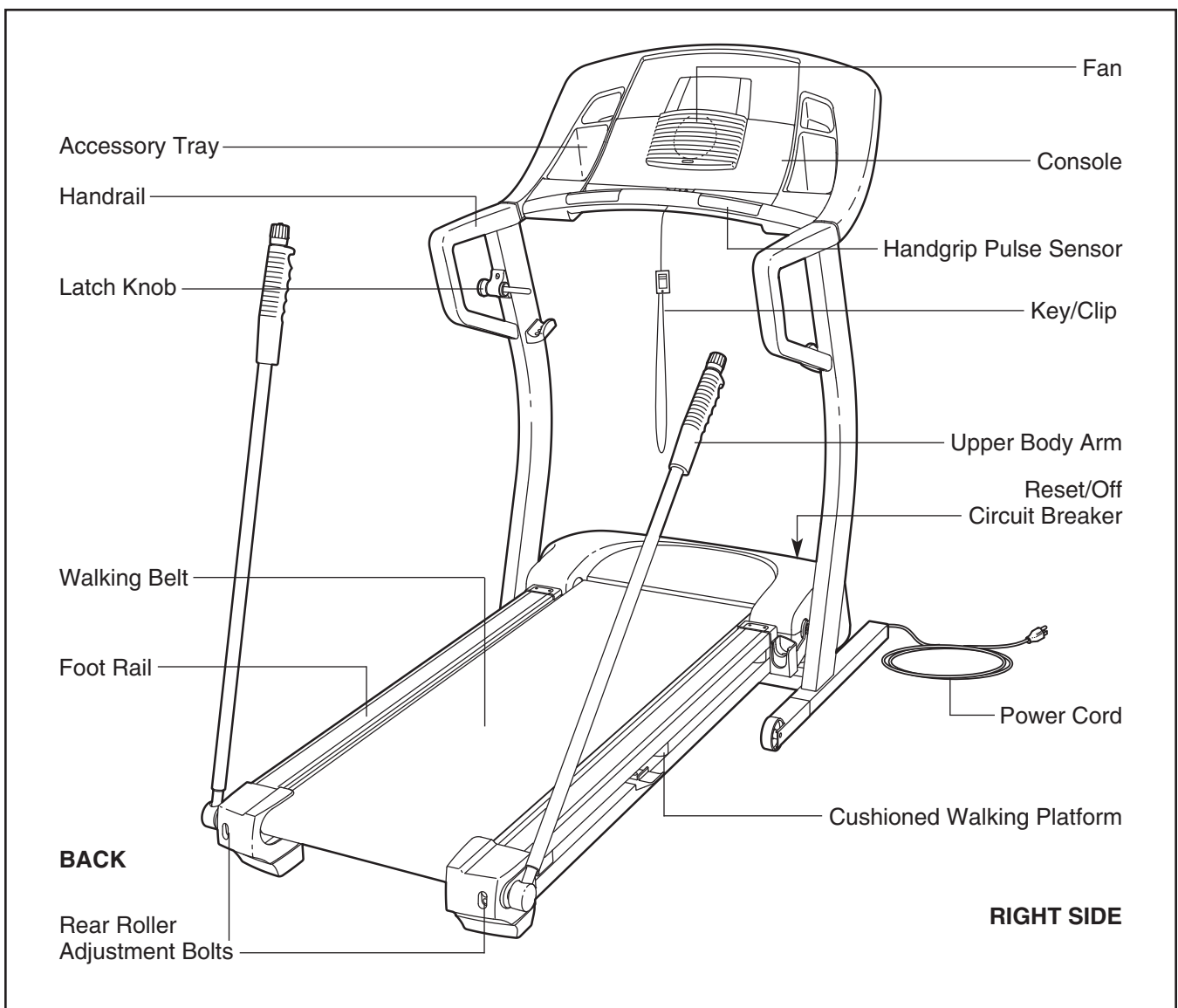

ASSEMBLY

Assembly requires two persons. Set the treadmill in a cleared area and remove all packing materials. Do not dispose of the packing materials until assembly is completed. Note: The underside of the treadmill walking belt is coated with high-performance lubricant. During shipping, a small amount of lubricant may be transferred to the top of the walking belt or the shipping carton. This is a normal condition and does not affect treadmill performance. If there is lubricant on top of the walking belt, simply wipe off the lubricant with a soft cloth and a mild, non-abrasive cleaner.

Assembly requires the included allen wrenches  **and your own Phillips screwdriver** , **wire cutters** , **and rubber mallet** .

For help identifying the assembly hardware, see the drawings below. Note: The assembly hardware and other small parts are packaged in separate part bags. **If a part is not found in the part bags, check to see if the part has been preassembled.**

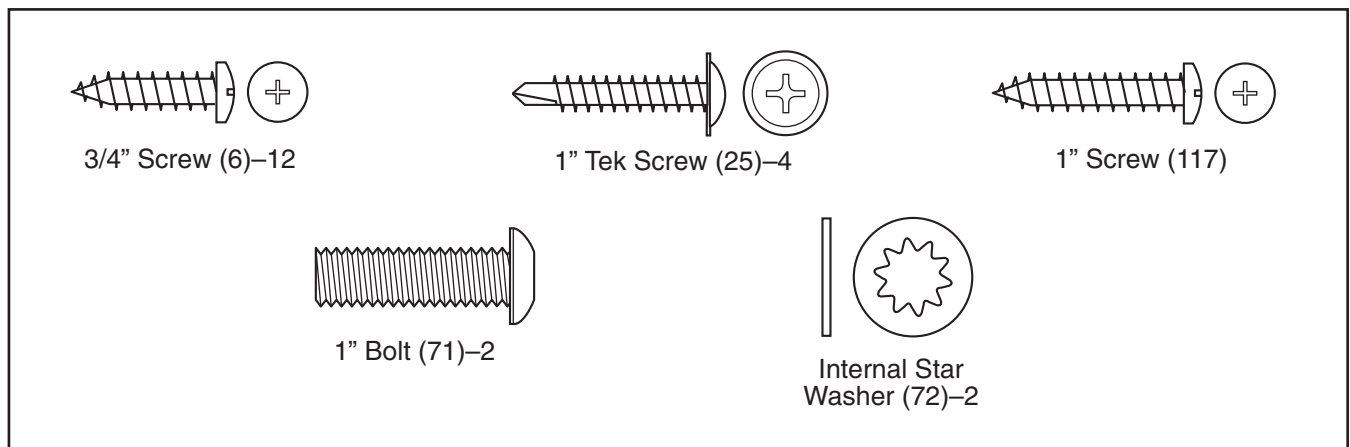

1. With the help of a second person, carefully raise the treadmill to the upright position as shown.

Insert one of the Extension Legs (106) into the treadmill as shown. Make sure that the Extension Leg is turned so the Base Pad (100) is on the bottom. If necessary, tip the Uprights (82) forward as you insert the Extension Leg.

Insert the other Extension Leg (not shown) in the same way.

Note: To prevent damage to the Upper Body Arms (35) if they are moved too far sideways, the lower end of each Upper Body Arm features a breakaway connector. If one of the Upper Body Arms breaks away, simply press the lower end back onto the Ball Joint (7 [not shown]).

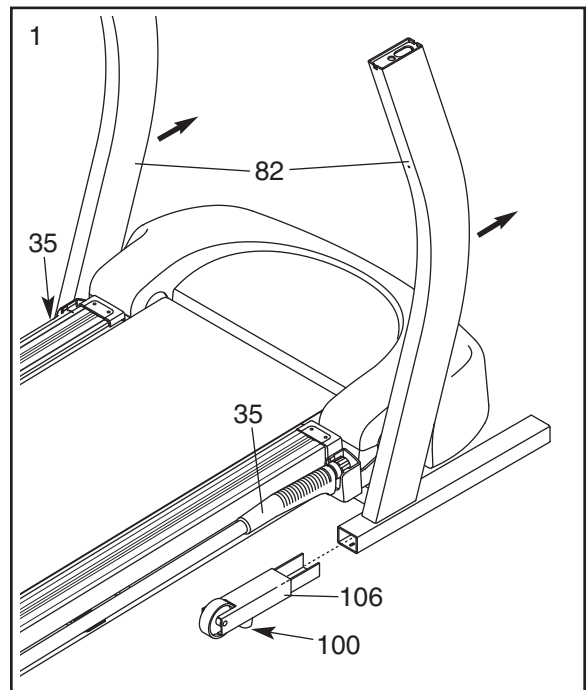

- With the help of a second person, carefully lower the Uprights (82) as shown. Note: It may be helpful to place your foot on one of the Wheels (108) as you tip the Uprights. **Make sure that the Extension Legs (106) remain in the Uprights.**

Attach each Extension Leg (106) with two 1" Tek Screws (25) and a Base Pad (100) as shown. Note: Attach the lower Tek Screw (without the Base Pad) first.

Note: One replacement Base Pad (100) may be included. If a Base Pad becomes worn and needs to be replaced, use the replacement Base Pad.

With the help of a second person, carefully tip the Uprights (82) back to the vertical position.

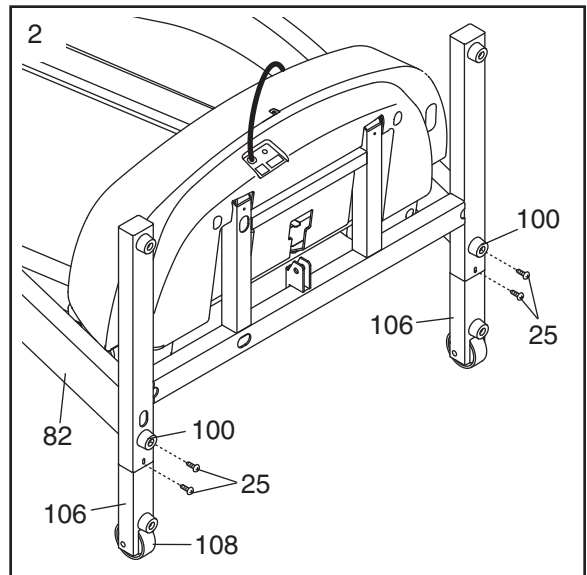

- With the help of a second person, hold the Console Base (85) near the Uprights (82) as shown.

Connect the Wire Harness (83) to the wire harness in the Right Handrail Bracket (113). **Make sure to connect the connectors properly (see the inset drawing). The connectors should slide together easily and snap into place.** If the connectors do not slide together easily and snap into place, turn one connector and then try again. **IF THE CONNECTORS ARE NOT CONNECTED PROPERLY, THE CONSOLE MAY BE DAMAGED WHEN THE POWER IS TURNED ON.** Insert the wire harnesses into the right Upright (82).

Hold the Handrail Brackets (73, 113) on top of the Uprights (82). Finger tighten two 1" Bolts (71) with Internal Star Washers (72) into the Handrail Brackets and the Uprights. **Press the Handrail Brackets towards the center of the treadmill.** Then, tighten both Bolts.

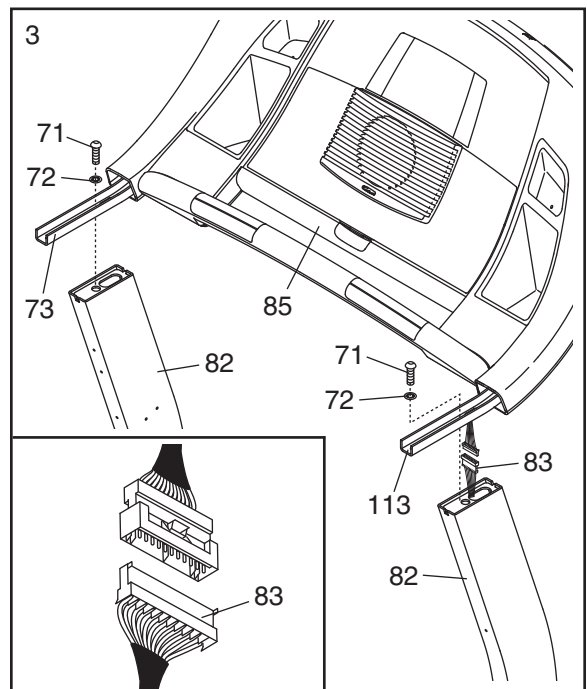

- Attach the Storage Latch (76) to the left Upright (82) with two 3/4" Screws (6). Make sure that the large hole in the Storage Latch is on the side shown.

Remove the knob from the pin. Make sure that the collar and the spring are on the pin. Insert the pin into the Storage Latch (76), and then tighten the knob back onto the pin.

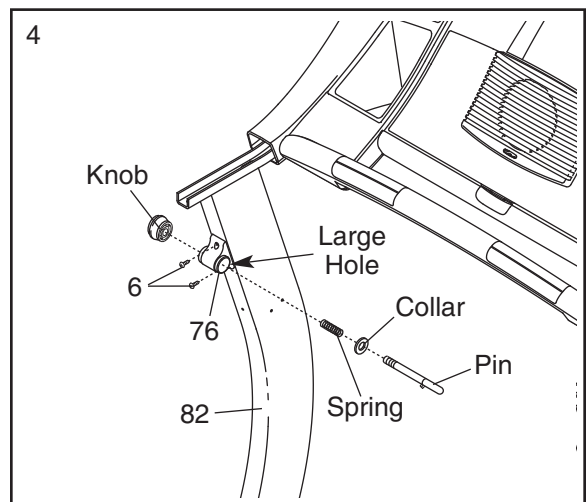

5. Identify the Left and Right Handrails (68, 81); the curved edges of the Handrails should be on the outside (see the end views of the Handrails in the inset drawing).

Slide the Right Handrail (81) onto the Right Handrail Bracket (113), and press the lip on the front of the Right Handrail under the Console Base (85). (Note: It may be helpful to tip the Right Handrail and to tap it with a rubber mallet to correctly position it.) Tighten two 3/4" Screws (6) and a 1" Screw (117) into the Right Handrail in the locations shown. Note: It may be necessary to move the lower end of the Right Handrail slightly to align the lower screw hole.

Attach the Left Handrail (68) in the same way.

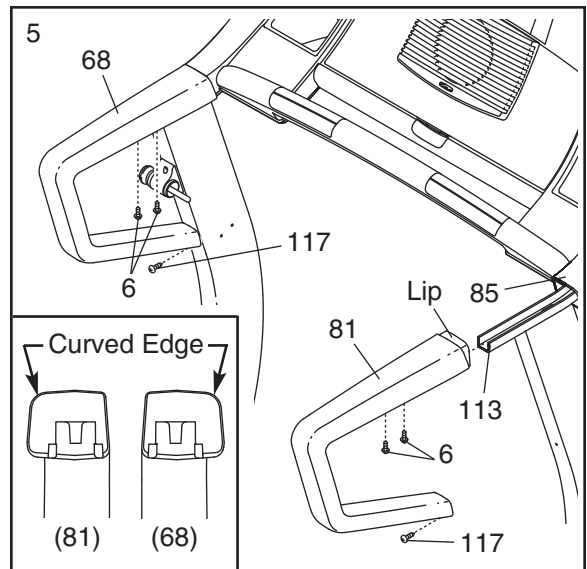

6. Attach each Upper Body Arm Holder (77) to an Upright (82) with two 3/4" Screws (6).

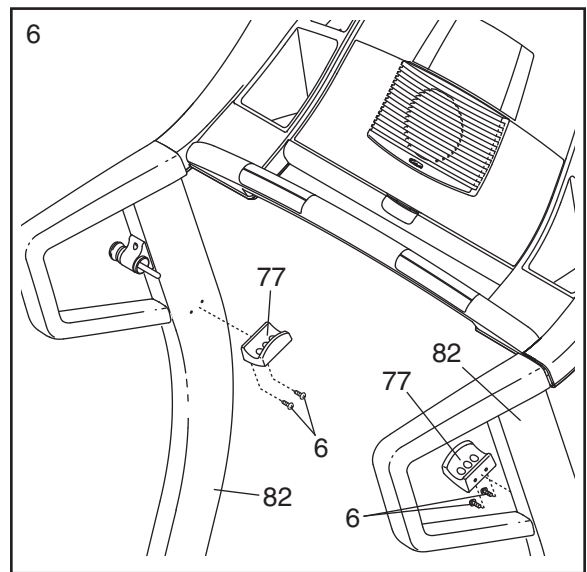

7. **Make sure that all parts are properly tightened before you use the treadmill.** Note: Extra hardware may be included. Keep the included allen wrenches in a secure place. The large allen wrench is used to adjust the walking belt (see page 28). To protect the floor or carpet, place a mat under the treadmill.

If you purchase the optional chest pulse sensor (see page 23), follow the steps below to install the receiver and the short jumper wire included with the chest pulse sensor.

1. **Make sure that the power cord is unplugged.** Remove the indicated 3/4" Screw (6) and the Access Door (94) from the back of the Console Back (95).
2. Remove the paper from the adhesive pad on the back of the receiver (A). **Hold the receiver so the small cylinder is near the lower edge of the receiver and is facing the Console (88) as shown.** Firmly press the receiver onto the indicated corner of the Access Door (94). Connect the wire on the receiver to the indicated wire extending from the Console.
3. **Make sure that no wires are pinched.** Reattach the Access Door (94) with the 3/4" Screw (6). The other wires included with the receiver may be discarded.

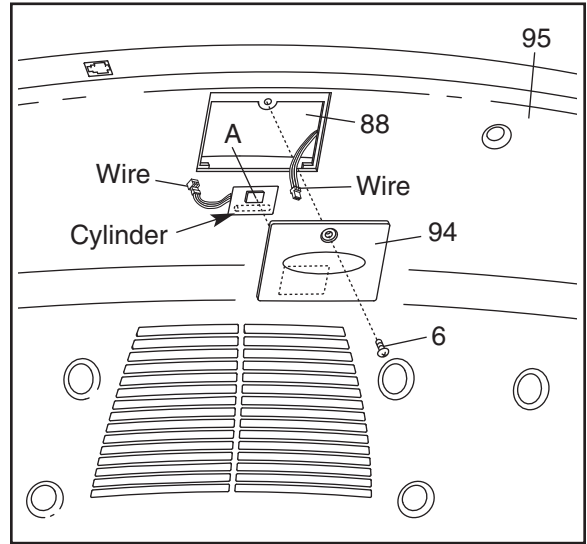

TREADMILL OPERATION

THE PERFORMANT LUBE™ WALKING BELT

Your treadmill features a walking belt coated with PERFORMANT LUBE™, a high-performance lubricant. **IMPORTANT: Never apply silicone spray or other substances to the walking belt or the walking platform. Such substances will deteriorate the walking belt and cause excessive wear.**

HOW TO PLUG IN THE POWER CORD

⚠ DANGER: Improper connection of the equipment-grounding conductor can result in an increased risk of electric shock. Check with a qualified electrician or serviceman if you are in doubt as to whether the product is properly grounded. Do not modify the plug provided with the product—if it will not fit the outlet, have a proper outlet installed by a qualified electrician.

Your treadmill, like any other type of sophisticated electronic equipment, can be seriously damaged by sudden voltage changes in your home's power. Voltage surges, spikes, and noise interference can result from weather conditions or from other appliances being turned on or off. **To decrease the possibility of your treadmill being damaged, always use a surge suppressor with your treadmill (see drawing 1 at the right).** To purchase a surge suppressor, see your local PROFORM dealer or call toll-free 1-888-533-1333 and order part number 146148.

Use only a single-outlet surge suppressor that is UL 1449 listed as a transient voltage surge suppressor (TVSS). The surge suppressor must have a UL suppressed voltage rating of 400 volts or less and a minimum surge dissipation of 450 joules. The surge suppressor must be electrically rated for 120 volts AC and 15 amps. There must be a monitoring light on the surge suppressor to indicate whether it is functioning properly. Failure to use a properly functioning surge suppressor could result in damage to the control system of the treadmill. If the control system is damaged, the walking belt may change speed or stop unexpectedly, which may result in a fall and serious injury.

This product must be grounded. If it should malfunction or break down, grounding provides a path of least resistance for electric current to reduce the risk of electric shock. This product is equipped with a cord having

an equipment-grounding conductor and a grounding plug. **Plug the power cord into a surge suppressor, and plug the surge suppressor into an appropriate outlet that is properly installed and grounded in accordance with all local codes and ordinances. Important: The treadmill is not compatible with GFCI-equipped outlets.**

This product is for use on a nominal 120-volt circuit, and has a grounding plug that looks like the plug illustrated in drawing 1 below. A temporary adapter that looks like the adapter illustrated in drawing 2 may be used to connect the surge suppressor to a 2-pole receptacle as shown in drawing 2 if a properly grounded outlet is not available.

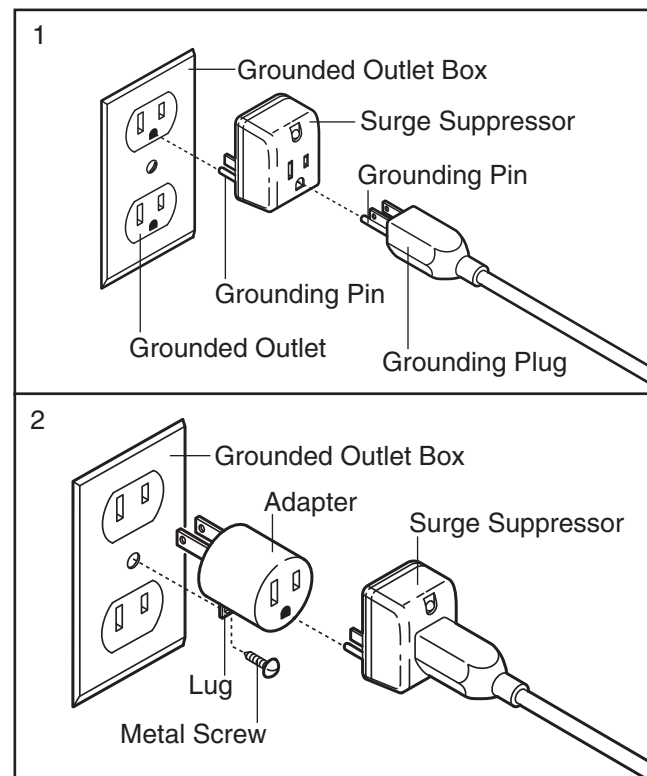

The temporary adapter should be used only until a properly grounded outlet (drawing 1) can be installed by a qualified electrician.

The green-colored rigid ear, lug, or the like extending from the adapter must be connected to a permanent ground such as a properly grounded outlet box cover. Whenever the adapter is used it must be held in place by a metal screw. **Some 2-pole receptacle outlet box covers are not grounded. Contact a qualified electrician to determine if the outlet box cover is grounded before using an adapter.**

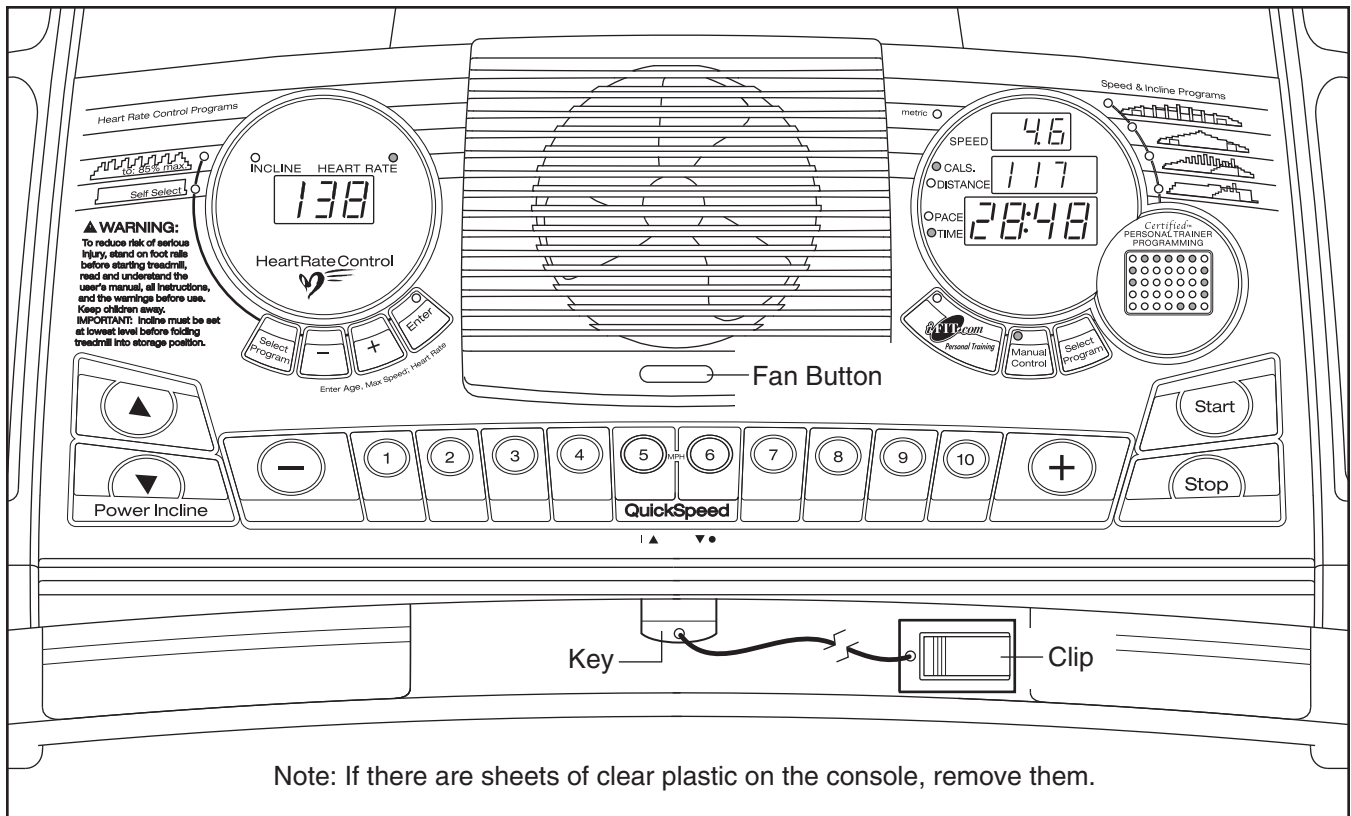

FEATURES OF THE CONSOLE

The treadmill console offers an impressive array of features designed to help you get the most from your workouts.

While the manual mode of the console is selected, the speed and incline of the treadmill can be changed with the touch of a button. As you exercise, the console will display instant exercise feedback. You can even measure your heart rate using the handgrip pulse sensor or the optional chest pulse sensor (see page 23).

In addition, the console offers four preset programs. Each program automatically controls the speed and incline of the treadmill as it guides you through an effective workout. Two heart rate programs are also offered. Each program adjusts the speed and incline of the treadmill to keep your heart rate near a target heart rate while you exercise. Note: The heart rate programs require the use of the optional chest pulse sensor.

The console also features iFIT.com interactive technology. Having iFIT.com technology is like having a per-

sonal trainer in your home. Using the included audio cable, you can connect the treadmill to your home stereo, portable stereo, computer, or VCR and play special iFIT.com CD and video programs. iFIT.com CD and video programs automatically control the speed and incline of the treadmill as a personal trainer guides you through every step of your workout. High-energy music provides added motivation. **To purchase other iFIT.com CDs or videocassettes, visit our Web site at www.iFIT.com.**

With the treadmill connected to your computer, you can also go to our Web site at www.iFIT.com and access programs directly from the internet. Additional options are soon to be available. **See www.iFIT.com for more information.**

To use the manual mode of the console, follow the steps beginning on page 12. **To use a preset program,** see page 14. **To use a heart rate program,** see page 16. **To use an iFIT.com CD or video program,** see page 20. **To use iFIT.com programs directly from our Web site,** see page 22.

HOW TO TURN ON THE POWER

1 Plug in the power cord (see page 10).

2 Locate the reset/off circuit breaker on the treadmill near the power cord. Make sure that the circuit breaker is in the reset position.

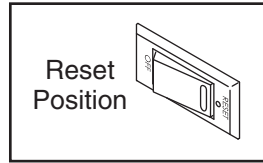

3 Stand on the foot rails of the treadmill. Find the clip attached to the key (see the drawing on page 11) and slide the clip onto the waistband of your clothes. Next, route the cord attached to the clip **under the handgrip pulse sensor**, and insert the key into the console. After a moment, the displays and various indicators will light. **Test the clip by carefully taking a few steps backward until the key is pulled from the console. If the key is not pulled from the console, adjust the position of the clip.**

HOW TO USE THE MANUAL MODE

1 Insert the key fully into the console.

See HOW TO TURN ON THE POWER above.

2 Select the manual mode.

When the key is inserted, the manual mode will be selected and the indicator on the Manual Control button will light. If you have selected a program, press the Manual Control button to reselect the manual mode.

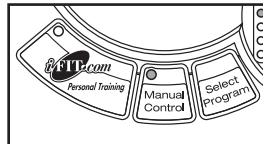

3 Press the Start button or the Speed + button to start the walking belt.

A moment after the button is pressed, the walking belt will begin to move at 1 mph. Hold the handrails and begin walking. As you exercise, change the

speed of the walking belt as desired by pressing the Speed + and – buttons. Each time a button is pressed, the speed setting will change by 0.1 mph; if a button is held down, the speed setting will change in increments of 0.5 mph. To change the speed setting quickly, press the Quick Speed buttons.

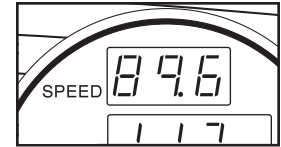

To stop the walking belt, press the Stop button. The Pace/Time display will begin to flash. To restart the walking belt, press the Start button or the Speed + button.

Note: The first time the treadmill is used, observe the alignment of the walking belt, and align the walking belt if necessary (see page 28).

4 Change the incline of the treadmill as desired.

To change the incline of the treadmill, press the Incline buttons. Each time a button is pressed, the incline will change by 0.5%.

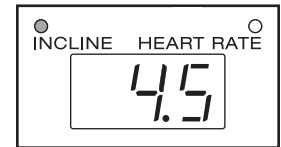

5 Follow your progress with the matrix and the displays.

The matrix—When the manual mode or the iFIT.com mode is selected, the matrix will display a 1/4-mile track. As you exercise, the indicators around the track will light in succession until the entire track is lit. The track will then darken and the indicators will again begin to light in succession.

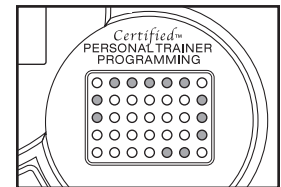

Incline/Heart Rate display—This display shows the incline level of the treadmill. This display will also show your heart rate when you use the handgrip pulse sensor or the optional chest pulse sensor.

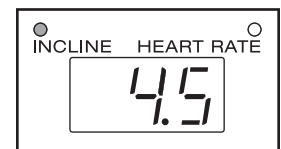

Speed display—This display shows the speed of the walking belt. Note: When the Metric indicator beside the display is lit, the console will display speed and distance in kilometres; when the Metric indicator is not lit, the console will display speed and distance in miles. To change the unit of measurement, see THE INFORMATION MODE/DEMO MODE on page 23. **For simplicity, all instructions in this section refer to miles.**

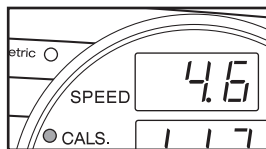

Calories/Distance display—This display shows the approximate number of calories you have burned and the distance that you have walked or run. The display will change from one number to the other every few seconds, as shown by the indicators beside the display.

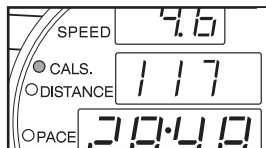

Pace/Time display—While the manual mode or the iFIT.com mode is selected, this display will show your pace (in minutes per mile) and the elapsed time. While a program is selected (except for the heart rate Self Select program), the display will show your pace and the time remaining in the program. The display will change from one number to the other every few seconds, as shown by the indicators beside the display.

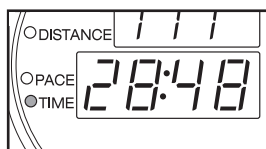

To reset the displays, press the Stop button, remove the key, and then reinsert the key.

6 Measure your heart rate if desired.

To use the handgrip pulse sensor, first make sure that your hands are clean. Next, **stand on the foot rails** and hold the handgrip pulse sensor with your palms on the metal contacts. **Avoid moving**

your hands. When your pulse is detected, two dashes (--) will appear in the Incline/Heart Rate display, and then your heart rate will be shown. **For the most accurate heart rate reading, continue to hold the contacts for about 15 seconds.**

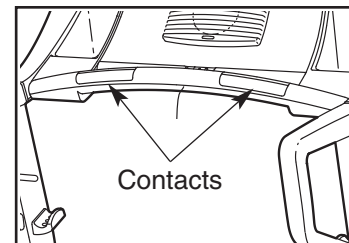

Note: The pulse bar is intended to be used only for heart rate measurement. **Do not use the pulse bar as a handlebar. Always hold the handrails for support when you are not measuring your heart rate.**

7 Turn on the fan if desired.

To turn on the fan, press the button below the fan. To turn on the fan at high speed, press the button a second time. To turn off the fan, press the button a third time. Note: A few minutes after the walking belt is stopped, the fan will automatically turn off.

8 When you are finished exercising, remove the key from the console.

Step onto the foot rails, press the Stop button, and **adjust the incline of the treadmill to the lowest setting. The incline must be at the lowest setting when the treadmill is folded to the storage position or the treadmill will be damaged.** Next, remove the key from the console and put it in a secure place. **Note: If the displays and various indicators on the console remain lit after the key is removed, the console is in the “demo” mode. See page 23 and turn off the demo mode.**

When you are finished using the treadmill, move the on/off switch near the power cord to the off position and unplug the power cord.

HOW TO USE PRESET PROGRAMS

1 Insert the key fully into the console.

See HOW TO TURN ON THE POWER on page 12.

2 Select one of the preset programs.

When the key is inserted, the manual mode will be selected. To select a preset program, press the **right Select Program** button repeatedly until one of the four preset program indicators lights.

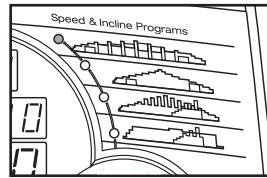

The diagrams beside the preset program indicators show how the speed and incline of the treadmill will change during the preset programs. When a preset program is selected, the Speed display will flash the maximum speed setting of the program for a few seconds, and the Incline/Heart Rate display will flash the maximum Incline setting. The Pace/Time display will show how long the program will last.

The matrix will show the first four speed settings of the program.

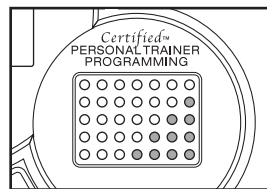

3 Press the Start button or the Speed + button to start the program.

A moment after the button is pressed, the treadmill will automatically adjust to the first speed and incline settings of the program. Hold the handrails and begin walking.

Each program is divided into several time segments of different lengths. One speed setting and one incline setting are programmed for each segment. Note: The same speed setting and/or incline setting may be programmed for two or more consecutive segments.

The speed setting for the first segment is shown in the flashing Current Segment column of the matrix. (The incline settings are not shown in the matrix.) The speed settings for the next four segments are shown in the columns to the right.

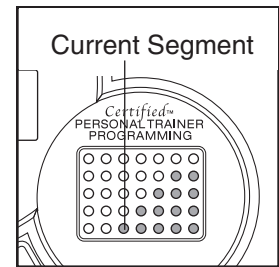

When only three seconds remain in the first segment of the program, both the Current Segment column and the column to the right will flash and a series of tones will sound. If the speed and/or incline of the treadmill is about to change, the Speed display and/or the Incline display will flash to alert you. When the first segment ends, *all speed settings will move one column to the left*. The speed setting for the second segment will then be shown in the flashing Current Segment column and the treadmill will automatically adjust to the speed and incline settings for the second segment. Note: If all of the indicators in the Current Segment column are lit after the speed settings have moved to the left, *the speed settings may move downward* so that only the highest indicators appear in the matrix. If some of the indicators in the Current Segment column are not lit when the speed settings move to the left again, the speed settings will move back up.

The program will continue in this way until the speed setting for the last segment is shown in the Current Segment column of the matrix and the last segment ends. The walking belt will then slow to a stop.

If the speed or incline setting is too high or too low at any time during the program, you can manually override the setting by pressing the Speed or Incline buttons. Every few times a Speed button is pressed, an additional indicator will light or darken in the Current Segment column. (If any of the columns to the right of the Current Segment column have the same number of lit indicators as the Current Segment column, an additional indicator may light or darken in those columns as well.)

Note: When the next segment of the program begins, the treadmill will automatically adjust to the speed and incline settings for the next segment.

To stop the program at any time, press the Stop button. The Pace/Time display will begin to flash. To restart the program, press the Start button or the Speed + button. The walking belt will begin to move at 1 mph. When the next segment of the program begins, the treadmill will automatically adjust to the speed and incline settings for the next segment.

4 Follow your progress with the displays.

See step 5 on page 12.

5 Measure your heart rate if desired.

See step 6 on page 13.

6 Turn on the fan if desired.

See step 7 on page 13.

7 When you are finished exercising, remove the key from the console.

When the program ends, **make sure that the incline of the treadmill is at the lowest setting.** Next, remove the key from the console and put it in a secure place. **Note: If the displays and various indicators on the console remain lit after the key is removed, the console is in the “demo” mode. See page 23 and turn off the demo mode.**

When you are finished using the treadmill, move the on/off switch near the power cord to the off position and unplug the power cord.

HOW TO USE HEART RATE PROGRAMS

⚠ CAUTION: If you have heart problems, or if you are over 60 years of age and have been inactive, do not use the heart rate programs. If you are taking medication regularly, consult your physician to find whether the medication will affect your exercise heart rate.

1 Put on the optional chest pulse sensor (see page 23).

You must wear the optional chest pulse sensor to use a heart rate program.

2 Insert the key fully into the console.

See HOW TO TURN ON THE POWER on page 12.

3 Select a heart rate program.

When the key is inserted, the manual mode will be selected. To select a heart rate program, press the **left Select Program** button repeatedly until one of the two heart rate program indicators lights.

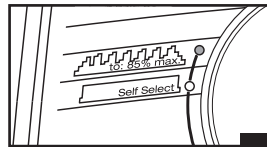

The diagrams beside the heart rate program indicators show how the target heart rate will change during the programs. During the 85% Max. program, your heart rate will reach approximately 85% of your *estimated maximum heart rate*; during the Self Select program, your heart rate will remain near a level that you select.

Note: Your estimated maximum heart rate is determined by subtracting your age from 220. For example, if you are 30 years old, your estimated maximum heart rate is 190 beats per minute ($220 - 30 = 190$).

During heart rate programs, the matrix will show a moving graphic that represents your heart rate. Each time a heartbeat is detected, an additional peak will appear.

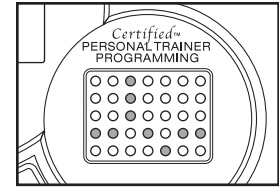

4 Enter your age.

When a heart rate program is selected, the word “AGE” and the current age setting will flash in the Incline/Heart Rate display. If you have already entered your age, simply press the Enter button. If you have not entered your age, press the + and – buttons beside the Enter button to enter your age. Then, press the Enter button.

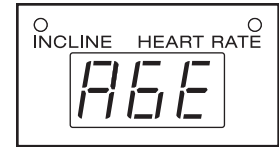

5 Enter a maximum speed.

After you have entered your age, the letters “SPd” and the maximum speed setting of the program will flash in the Incline/Heart Rate display. If desired, press the + and – buttons beside the Enter button to change the maximum speed setting. When the desired setting is shown, press the Enter button.

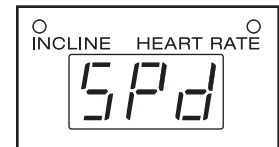

If the 85% Max. program is selected, go to step 7. If the Self Select program is selected, go to step 6.

6 Enter a target heart rate.

After you have entered a maximum speed setting, the letters “PLS” and the target heart rate setting for the program will flash in the Incline/Heart Rate display. If desired, press the + and – buttons beside the Enter button to change the target heart rate setting. When the desired setting is shown, press the Enter button.

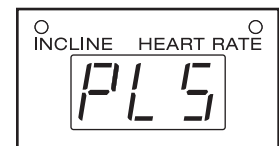

7 Press the Start button or the Speed + button to start the program.

A moment after the button is pressed, the treadmill will automatically adjust to the first speed and incline settings of the program. Hold the handrails and begin walking.

Each heart rate program is divided into several time segments of different lengths. One target heart rate is programmed for each segment. Note: If the Self Select program is selected, the same target heart rate is programmed for all segments.

During each segment, the console will regularly compare your heart rate to the current target heart rate. If your heart rate is too far below or above the target heart rate, the speed of the treadmill will automatically increase or decrease to bring your heart rate closer to the target heart rate. If the speed reaches the maximum speed setting of the program (see step 5 on page 16) and your heart rate is still too far below the current target heart rate, the incline of the treadmill will also increase to bring your heart rate closer to the target heart rate.

During the last three seconds of each segment, a series of tones will sound and the Speed display and the Incline display will flash.

The program will continue until the last segment ends. The walking belt will then slow to a stop.

If the speed or incline setting is too high or too low at any time during the program, you can adjust the setting with the Speed or Incline buttons. However, each time the console compares your heart rate to the current target heart rate, the speed and/or incline of the treadmill may automatically change to bring your heart rate closer to the target heart rate.

If your pulse is not detected during the program, the letters "PLS" will flash in the Incline/Heart Rate display and the speed and incline of the treadmill may automatically decrease until your pulse is detected. If this occurs, see the instructions included with the optional chest pulse sensor.

To stop the program, press the Stop button. Heart rate programs cannot be stopped temporarily and then restarted. To use a heart rate program again, reselect the program and start it at the beginning.

8 Follow your progress with the displays.

See step 5 on page 12.

9 Turn on the fan if desired.

See step 7 on page 13.

10 When you are finished exercising, remove the key from the console.

See step 7 on page 15.

HOW TO CONNECT THE TREADMILL TO YOUR CD PLAYER, VCR, OR COMPUTER

To use **iFIT.com CDs**, the treadmill must be connected to your portable CD player, portable stereo, home stereo, or computer with CD player. See pages 18 and 19 for connecting instructions. To use **iFIT.com video-cassettes**, the treadmill must be connected to your VCR. See page 20 for connecting instructions. To use **iFIT.com programs directly from our Web site**, the treadmill must be connected to your home computer. See page 19 for connecting instructions.

HOW TO CONNECT YOUR PORTABLE CD PLAYER

Note: If your CD player has separate **LINE OUT** and **PHONES** jacks, see instruction A below. If your CD player has only one jack, see instruction B.

- A. Plug one end of the audio cable into the jack on the front of the treadmill near the power cord. Plug the other end of the cable into the **LINE OUT** jack on your CD player. Plug your headphones into the **PHONES** jack.

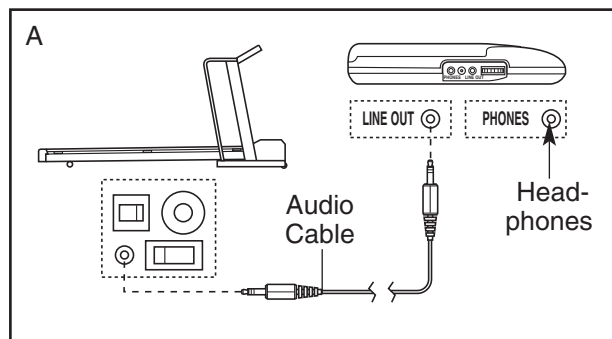

- B. Plug one end of the audio cable into the jack on the front of the treadmill near the power cord. Plug the other end of the cable into a 3.5mm Y-adaptor (available at electronics stores). Plug the Y-adaptor into the **PHONES** jack on your CD player. Plug your headphones into the other side of the Y-adaptor.

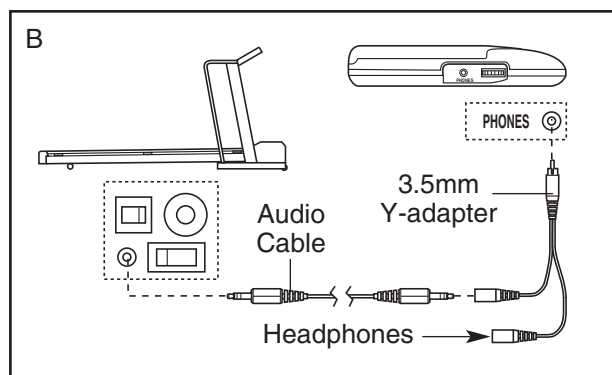

HOW TO CONNECT YOUR PORTABLE STEREO

Note: If your stereo has an **RCA-type AUDIO OUT** jack, see instruction A below. If your stereo has a **3.5 mm LINE OUT** jack, see instruction B. If your stereo has only a **PHONES** jack, see instruction C.

- A. Plug one end of the audio cable into the jack on the front of the treadmill near the power cord. Plug the other end of the cable into the adaptor. Plug the adaptor into an **AUDIO OUT** jack on your stereo.

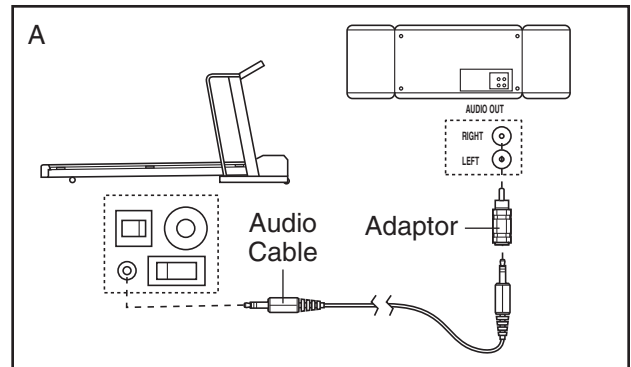

- B. Plug one end of the audio cable into the jack on the front of the treadmill near the power cord. Plug the other end of the cable into the **LINE OUT** jack on your stereo.

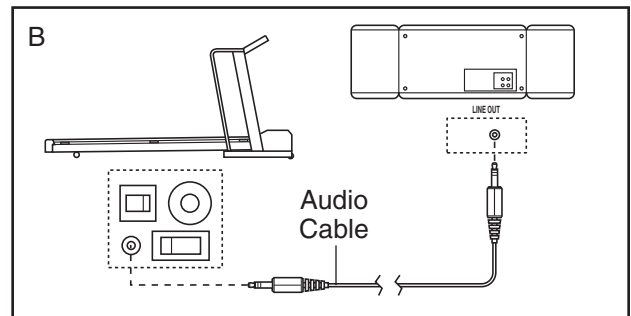

- C. Plug one end of the audio cable into the jack on the front of the treadmill near the power cord. Plug the other end of the cable into a 3.5mm Y-adaptor (available at electronics stores). Plug the Y-adaptor into the **PHONES** jack on your stereo. Plug your headphones into the other side of the Y-adaptor.

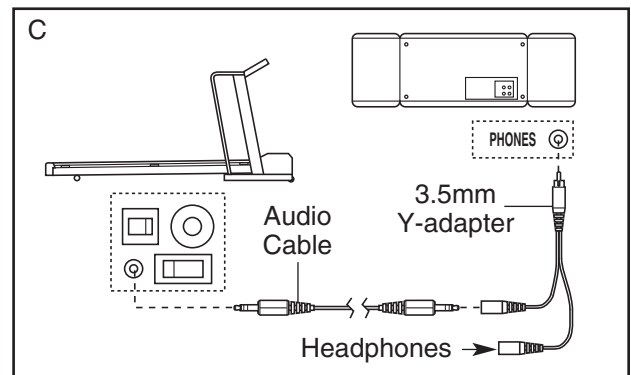

HOW TO CONNECT YOUR HOME STEREO

Note: If your stereo has an unused **LINE OUT** jack, see instruction **A** below. If the **LINE OUT** jack is being used, see instruction **B**.

- A. Plug one end of the audio cable into the jack on the front of the treadmill near the power cord. Plug the other end of the cable into the adaptor. Plug the adaptor into the **LINE OUT** jack on your stereo.

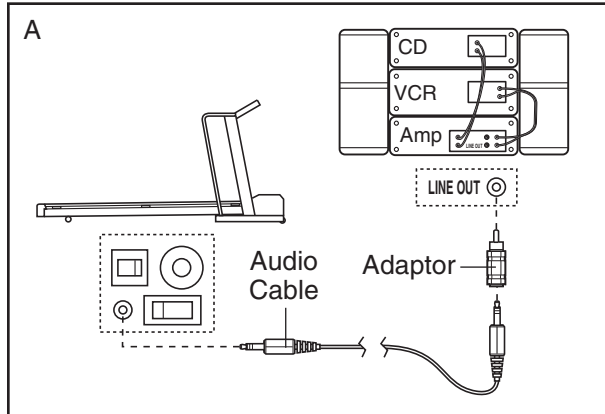

- B. Plug one end of the audio cable into the jack on the front of the treadmill near the power cord. Plug the other end of the cable into the adaptor. Plug the adaptor into an **RCA Y-adaptor** (available at electronics stores). Next, remove the wire that is currently plugged into the **LINE OUT** jack on your stereo and plug the wire into the unused side of the **Y-adaptor**. Plug the **Y-adaptor** into the **LINE OUT** jack on your stereo.

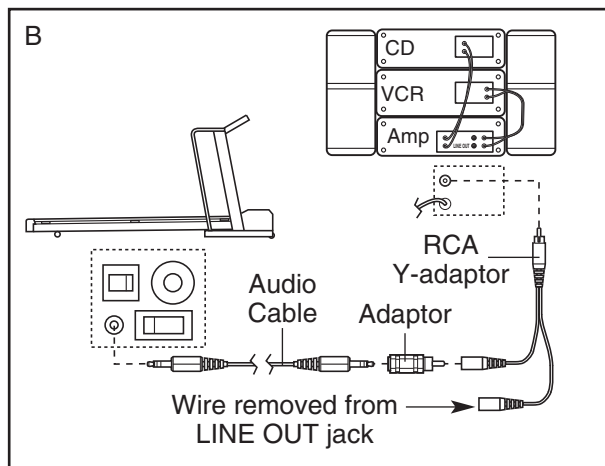

HOW TO CONNECT YOUR COMPUTER

Note: If your computer has a **3.5 mm LINE OUT** jack, see instruction **A**. If your computer has only a **PHONES** jack, see instruction **B**.

- A. Plug one end of the audio cable into the jack on the front of the treadmill near the power cord. Plug the other end of the cable into the **LINE OUT** jack on your computer.

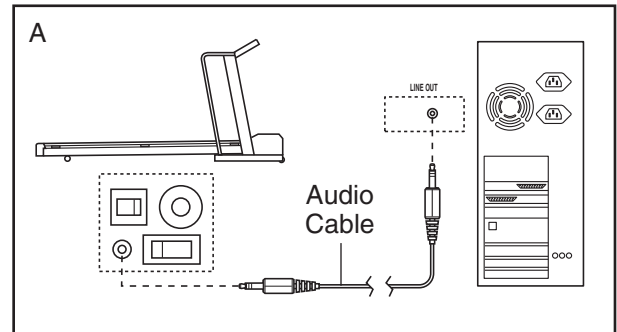

- B. Plug one end of the audio cable into the jack on the front of the treadmill near the power cord. Plug the other end of the cable into a **3.5mm Y-adaptor** (available at electronics stores). Plug the **Y-adaptor** into the **PHONES** jack on your computer. Plug your headphones or speakers into the other side of the **Y-adaptor**.

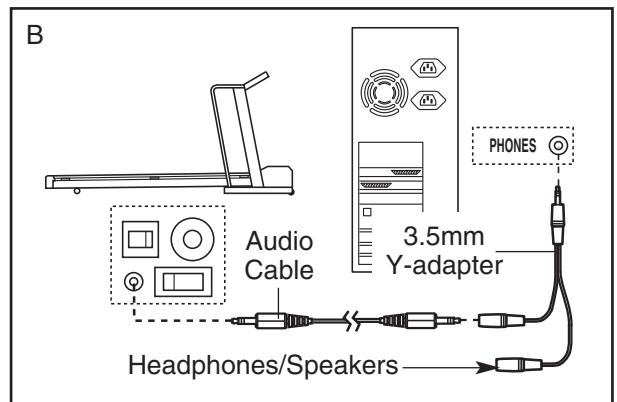

HOW TO CONNECT YOUR VCR

Note: If your VCR has an unused AUDIO OUT jack, see instruction A below. If the AUDIO OUT jack is being used, see instruction B. If you have a TV with a built-in VCR, see instruction B. If your VCR is connected to your home stereo, see **HOW TO CONNECT YOUR HOME STEREO** on page 19.

- A. Plug one end of the audio cable into the jack on the front of the treadmill near the power cord. Plug the other end of the cable into the included adapter. Plug the adapter into the AUDIO OUT jack on your VCR.

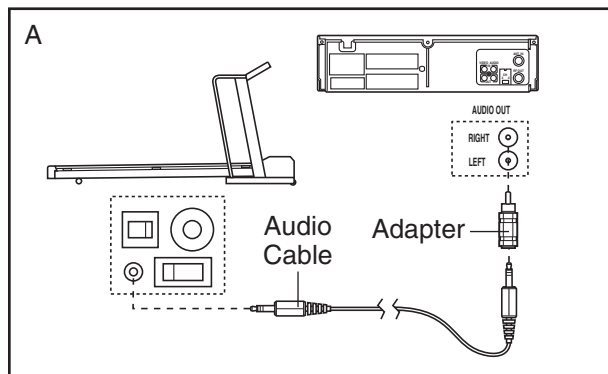

- B. Plug one end of the audio cable into the jack on the front of the treadmill near the power cord. Plug the other end of the cable into the included adapter. Plug the adapter into an RCA Y-adapter (available at electronics stores). Next, remove the wire that is currently plugged into the AUDIO OUT jack on your VCR and plug the wire into the unused side of the RCA Y-adapter. Plug the RCA Y-adapter into the AUDIO OUT jack on your VCR.

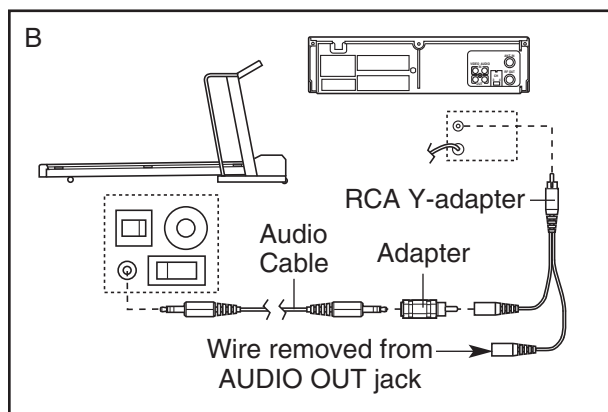

HOW TO USE iFIT.COM CD AND VIDEO PROGRAMS

To use iFIT.com CDs or videocassettes, the treadmill must be connected to your portable CD player, portable stereo, home stereo, computer with CD player, or VCR. See **HOW TO CONNECT THE TREADMILL TO YOUR CD PLAYER, VCR, OR COMPUTER** on pages 18 to 20. **Note:** To purchase iFIT.com CDs or videocassettes, visit our Web site at www.iFIT.com.

Follow the steps below to use an iFIT.com CD or video program.

1 Insert the key into the console.

See **HOW TO TURN ON THE POWER** on page 13.

2 Select the iFIT.com mode.

When the key is inserted, the manual mode will be selected. To use iFIT.com CDs or videocassettes, press the iFIT.com button. The indicator on the button will light.

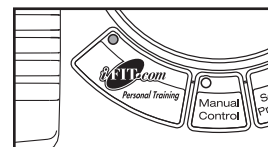

3 Insert the iFIT.com CD or videocassette.

If you are using an iFIT.com CD, insert the CD into your CD player. If you are using an iFIT.com videocassette, insert the videocassette into your VCR.

4 Press the PLAY button on your CD player or VCR.

A moment after the button is pressed, your personal trainer will begin guiding you through your workout. Simply follow your personal trainer's instructions. Note: If the Pace/Time display is flashing, press the Start button or the Speed + button on the console. The treadmill will not respond to a CD or video program while the Pace/Time display is flashing.

During the CD or video program, an electronic "chirping" sound will alert you when the speed and/or incline of the treadmill is about to change. **CAUTION: Always listen for the "chirp" and be prepared for speed and/or incline changes. In some instances, the speed and/or incline may change before the personal trainer describes the change.**

If the speed or incline settings are too high or too low, you can manually override the settings at any time by pressing the Speed or Incline buttons on the console. However, **when the next “chirp” is heard, the speed and/or incline will change to the next settings of the CD or video program.**

To stop the walking belt at any time, press the Stop button on the console. The Pace/Time display will begin to flash. To restart the program, press the Start button or the Speed + button. After a moment, the walking belt will begin to move at 1 mph. **When the next “chirp” is heard, the speed and incline will change to the next settings of the CD or video program.**

When the CD or video program is completed, the walking belt will stop and the Pace/Time display will begin to flash. Note: To use another CD or video program, press the Stop button or remove the key and go to step 1 on page 20.

Note: If the speed or incline of the treadmill does not change when a “chirp” is heard:

- **Make sure that the iFIT.com indicator is lit and that the Pace/Time display is not flashing. If the Pace/Time display is flashing, press the Start button or the Speed + button on the console.**
- **Adjust the volume of your CD player or VCR. If the volume is too high or too low, the console may not detect the program signals.**

- **Make sure that the audio cable is properly connected, that it is fully plugged in, and that it is not wrapped around a power cord.**
- **If you are using your portable CD player and the CD skips, set the CD player on the floor or another flat surface instead of on the console.**

5 Follow your progress with the matrix and the displays.

See step 5 on page 12.

6 Measure your heart rate if desired.

See step 6 on page 13.

7 Turn on the fan if desired.

See step 7 on page 13.

8 When you are finished exercising, remove the key from the console.

See step 7 on page 15.

CAUTION: Always remove iFIT.com CDs and videocassettes from your CD player and VCR when you are finished using them.

HOW TO USE PROGRAMS DIRECTLY FROM OUR WEB SITE

To use programs from our Web site, the treadmill must be connected to your home computer. See HOW TO CONNECT YOUR COMPUTER on page 19. In addition, you must have an internet connection and an internet service provider. A list of specific system requirements is found on our Web site.

Follow the steps below to use a program from our Web site.

1 Insert the key into the console.

See HOW TO TURN ON THE POWER on page 12.

2 Select the iFIT.com mode.

When the key is inserted, the manual mode will be selected. To use a program from our Web site, press the iFIT.com button. The indicator on the button will light.

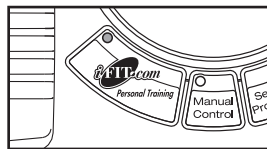

3 Go to your computer and start an internet connection.

4 Start your web browser, if necessary, and go to our Web site at www.iFIT.com.

5 Follow the desired links on our Web site to select a program.

Read and follow the on-line instructions for using a program.

6 Follow the on-line instructions to start the program.

When you start the program, an on-screen countdown will begin.

7 Return to the treadmill and stand on the foot pads. Find the clip attached to the key and slide the clip onto the waistband of your clothes.

When the on-screen countdown ends, the program will begin and the walking belt will begin to move.

Hold the handrails, step onto the walking belt, and begin walking. During the program, an electronic “chirping” sound will alert you when the speed and/or incline of the treadmill is about to change.

CAUTION: Always listen for the “chirp” and be prepared for speed and/or incline changes.

If the speed or incline settings are too high or too low, you can manually override the settings at any time by pressing the Speed or Incline buttons on the console. However, **when the next “chirp” is heard, the speed and/or incline will change to the next settings of the program.**

To stop the walking belt at any time, press the Stop button on the console. The Pace/Time display will begin to flash. To restart the program, press the Start button or the Speed + button. After a moment, the walking belt will begin to move at 1 mph. **When the next “chirp” is heard, the speed and incline will change to the next settings of the program.**

When the program is completed, the walking belt will stop and the Pace/Time display will begin to flash. Note: To use another program, press the Stop button and go to step 5.

Note: If the speed or incline of the treadmill does not change when a “chirp” is heard, make sure that the iFIT.com indicator is lit and that the Pace/Time display is not flashing. In addition, make sure that the audio cable is properly connected, that it is fully plugged in, and that it is not wrapped around a power cord.

8 Follow your progress with the matrix and the displays.

See step 5 on page 12.

9 When you are finished exercising, remove the key from the console.

See step 7 on page 15.

THE INFORMATION MODE/DEMO MODE

The console features an information mode that keeps track of the total number of hours that the treadmill has been used and the total number of miles that the walking belt has moved. The information mode also allows you to switch the console from miles per hour to kilometres per hour. In addition, the information mode allows you to turn on and turn off the demo mode.

To select the information mode, hold down the Stop button while inserting the key into the console. When the information mode is selected, the following information will be shown:

The Calories/Distance display will show the total number of miles (or kilometres) that the walking belt has moved.

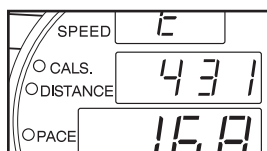

The Pace/Time display will show the total number of hours the treadmill has been used.

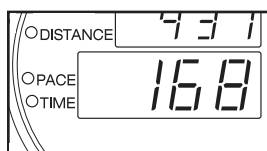

An "E" for English or an "M" for metric will appear in the Speed display. Press the Speed + button to change the unit of measurement.

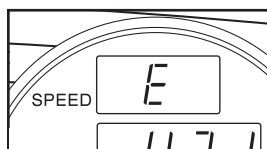

IMPORTANT: The Incline/Heart Rate display should be blank. If a "d" appears in the display, the console is in the "demo" mode. This mode is intended to be used

only when a treadmill is displayed in a store. While the console is in the demo mode, the power cord can be plugged in, the key can be removed from the console, and the displays and indicators on the console will automatically light in a preset sequence, although the buttons on the console will not operate. **If a "d" appears in the Incline/Heart Rate display while the information mode is selected, press the Speed – button so the display is blank.**

To exit the information mode, remove the key from the console.

THE OPTIONAL CHEST PULSE SENSOR

An optional chest pulse sensor provides hands-free operation and allows you to use the console's heart rate programs. **To purchase a chest pulse sensor, call toll-free 1-888-533-1333.**

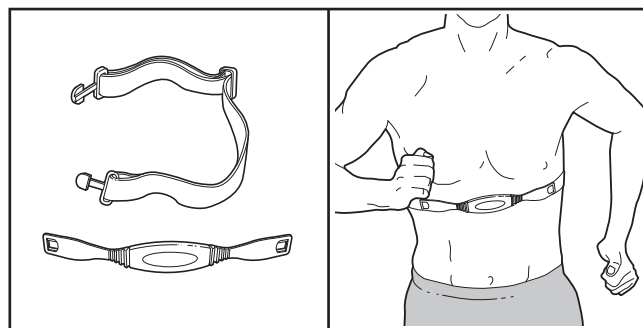

HOW TO USE THE UPPER BODY ARMS

As you walk on the treadmill, you can either hold the handrails or use the upper body arms. **When you are not using the arms, always set them in the arm housings at the base of the uprights (see the drawing below). Be careful not to step on the arms.**

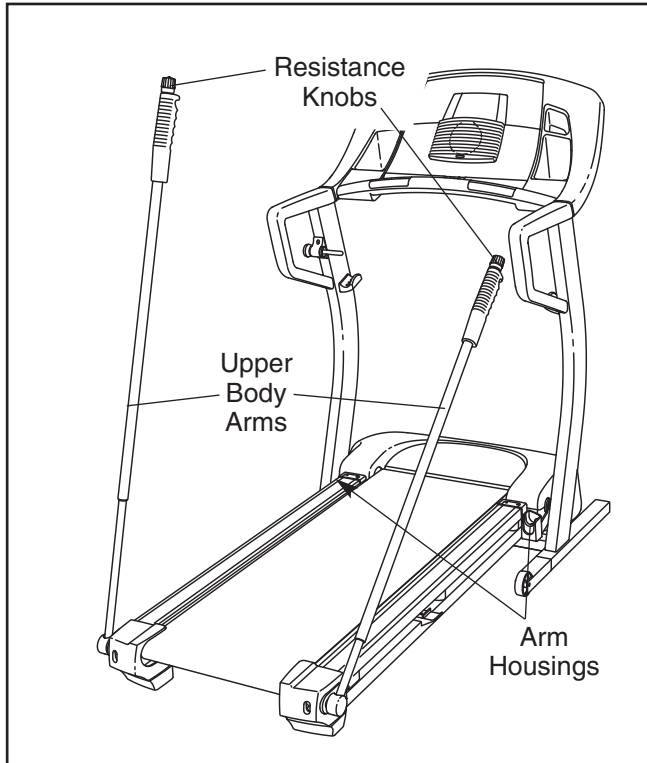

To add upper-body exercise to your workouts, hold the upper body arms and move them forward and back as you walk. Do not move the arms too far to the side. To vary the intensity of your upper-body exercise, adjust the resistance of the arms by turning the resistance knobs.

If you are using the upper body arms and you need to set them aside for a moment, step onto the foot rails and set the ends of the arms on the upper body arm holders as shown below. Never leave the arms on the console when the arms are not in use; allowing the arms to come in contact with the console may affect the operation of the treadmill.

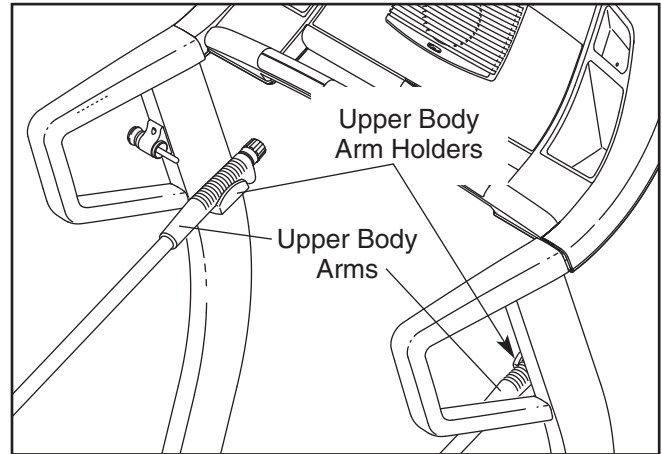

UPPER BODY ARM TROUBLESHOOTING

If the upper body arms do not slide easily, or if they make a squeaking noise, apply the included lubricant to the arms in the locations shown below. Slide the arms up and down several times to spread the lubricant.

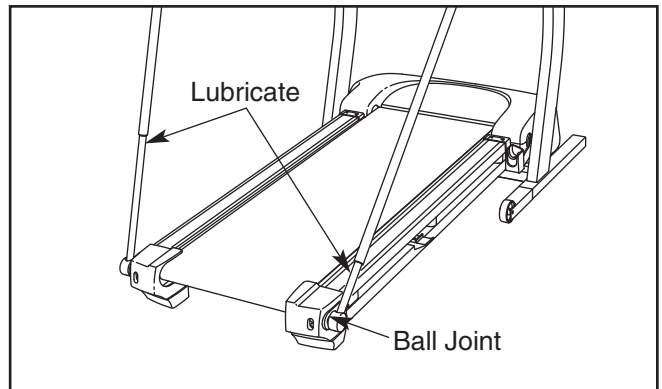

To prevent damage to the upper body arms if they are moved too far sideways, the lower end of each arm features a breakaway connector. If one of the arms breaks away, simply press the lower end back onto the ball joint (not shown).

HOW TO FOLD AND MOVE THE TREADMILL

HOW TO FOLD THE TREADMILL FOR STORAGE

Before folding the treadmill, adjust the incline to the lowest position and set the upper body arms in the arm housings. If this is not done, the treadmill may be permanently damaged. Next, unplug the power cord. **CAUTION: You must be able to safely lift 45 pounds (20 kg) to raise, lower, or move the treadmill.**

1. Hold the treadmill in the locations shown at the right. **To decrease the possibility of injury, bend your legs and keep your back straight. As you raise the treadmill, make sure to lift with your legs rather than your back.** Raise the treadmill about halfway to the vertical position.

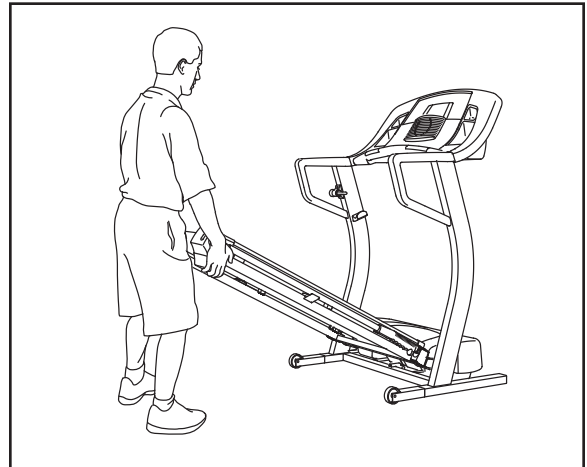

2. Move your right hand to the position shown and hold the treadmill firmly. Using your left hand, pull the latch knob to the left and hold it. Raise the treadmill until the catch is past the latch pin. Slowly release the latch knob. **Make sure that the catch is securely held by the latch pin.**

To protect the floor or carpet from damage, place a mat under the treadmill. Keep the treadmill out of direct sunlight. Do not leave the treadmill in the storage position in temperatures above 85° Fahrenheit.

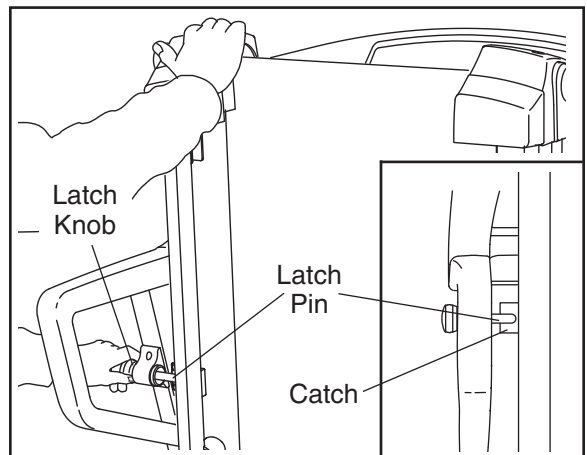

HOW TO MOVE THE TREADMILL

Before moving the treadmill, convert the treadmill to the storage position as described above. **Make sure that the frame is securely held by the latch pin.**

1. Hold the upper ends of the handrails. Place one foot on the base as shown.
2. Tilt the treadmill back until it rolls freely on the front wheels. Carefully move the treadmill to the desired location. **To reduce the risk of injury, use extreme caution while moving the treadmill. Do not move the treadmill over an uneven surface.**
3. Place one foot on the base, and carefully lower the treadmill until it is resting in the storage position.

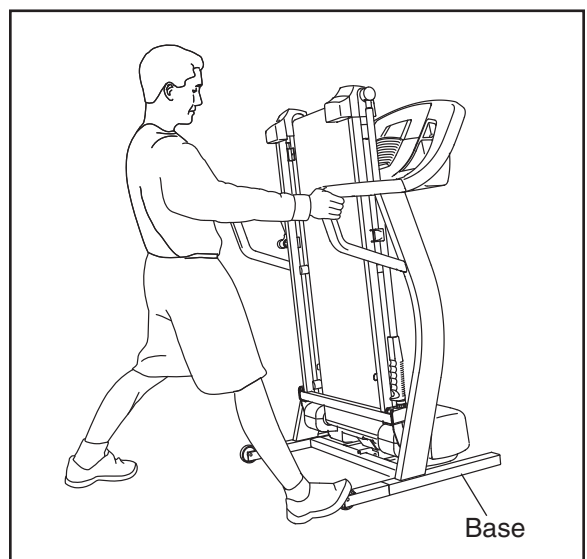

HOW TO LOWER THE TREADMILL FOR USE

1. Hold the treadmill firmly with your left hand. Pull the latch knob to the left and hold it. Pivot the treadmill down until the frame is past the latch pin.

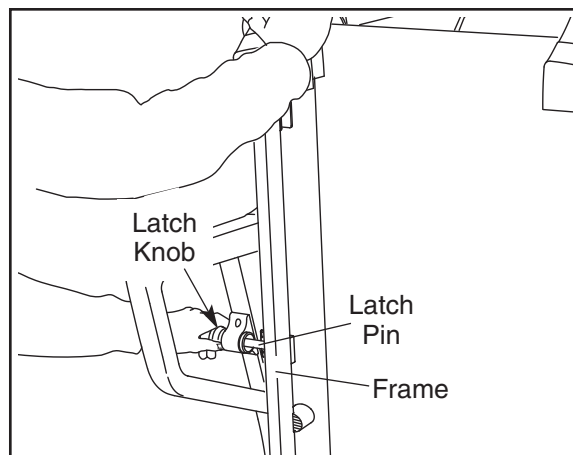

2. Hold the treadmill firmly with both hands, and lower the treadmill to the floor. **To decrease the possibility of injury, bend your legs and keep your back straight.**

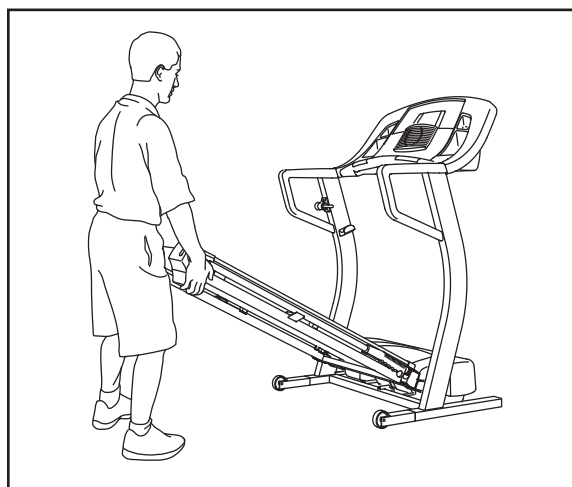

TROUBLESHOOTING

Most treadmill problems can be solved by following the instructions below. If further assistance is needed, please call our Customer Service Department toll-free at 1-888-533-1333, Monday through Friday, 6 a.m. until 6 p.m. Mountain Time (excluding holidays).

PROBLEM: The power does not turn on

SOLUTION: a. Make sure that the power cord is plugged into a surge suppressor, and that the surge suppressor is plugged into a properly grounded outlet (see page 10). Use only a single-outlet surge suppressor that meets all of the specifications described on page 10. Important: The treadmill is not compatible with GFCI-equipped outlets.

b. Make sure that the key is fully inserted into the console.

c. Check the reset/off circuit breaker located on the frame near the power cord. If the breaker protrudes as shown, the circuit breaker has tripped. To reset the circuit breaker, wait for five minutes and then press the breaker back in.

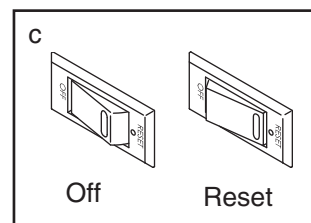

PROBLEM: The power turns off during use

SOLUTION: a. Check the reset/off circuit breaker located on the treadmill frame near the power cord (see 1. c. above). If the circuit breaker has tripped, wait for five minutes and then press the switch back in.

b. Make sure that the power cord is plugged in. If the power cord is plugged in, unplug it, wait for five minutes, and then plug it back in.

c. Remove the key from the console and then reinsert it.

PROBLEM: The displays of the console do not function properly

SOLUTION: a. Remove the key from the console and **UNPLUG THE POWER CORD**. With the help of a second person, carefully tip the Uprights (82) down as shown. Remove the three 3/4" Screws (6). Note: A Phillips screwdriver with at least a 5" shaft is required.

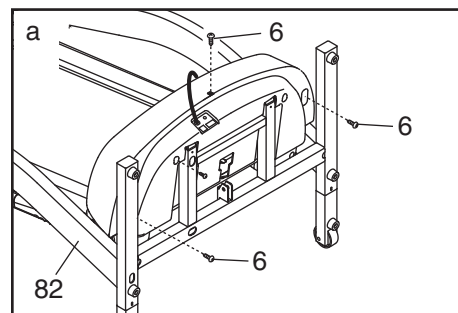

With the help of a second person, carefully raise the Uprights (82) as shown. Carefully pivot the Hood (39) off.

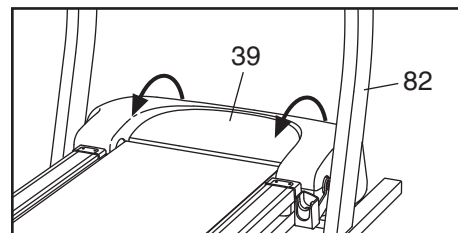

Locate the Reed Switch (24) and the Magnet (18) on the left side of the Pulley (114). Turn the Pulley until the Magnet is aligned with the Reed Switch. **Make sure that the gap between the Magnet and the Reed Switch is about 1/8".** If necessary, loosen the Screw (6) and move the Reed Switch slightly. Retighten the Screw. Reattach the Hood, and run the treadmill for a few minutes to check for a correct speed reading.

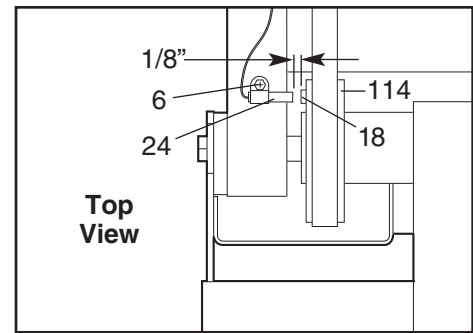

PROBLEM: The walking belt slows when walked on

SOLUTION: a. Use only a single-outlet surge suppressor that meets all of the specifications described on page 10.

b. If the walking belt is overtightened, treadmill performance may decrease and the walking belt may be permanently damaged. Remove the key and **UNPLUG THE POWER CORD**. Using the included allen wrench, turn both rear roller adjustment bolts counterclockwise 1/4 of a turn. When the walking belt is properly tightened, you should be able to lift **the edges** of the walking belt 3 to 4 inches off the walking platform. Be careful to keep the walking belt centered. Plug in the power cord, insert the key, and run the treadmill for a few minutes. Repeat until the walking belt is properly tightened.

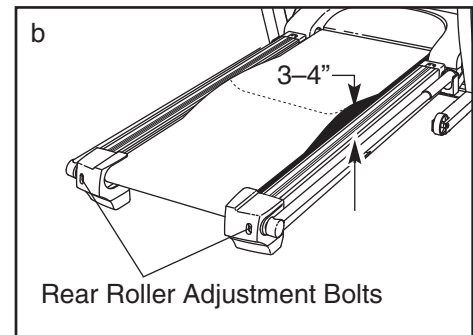

PROBLEM: The walking belt is off-center or slips when walked on

SOLUTION: a. If the walking belt is off-center, first remove the key and **UNPLUG THE POWER CORD**. **If the walking belt has shifted to the left**, use the allen wrench to turn the left rear roller bolt clockwise 1/2 of a turn; **if the walking belt has shifted to the right**, turn the bolt counterclockwise 1/2 of a turn. Be careful not to overtighten the walking belt. Plug in the power cord, insert the key, and run the treadmill for a few minutes. Repeat until the walking belt is centered.

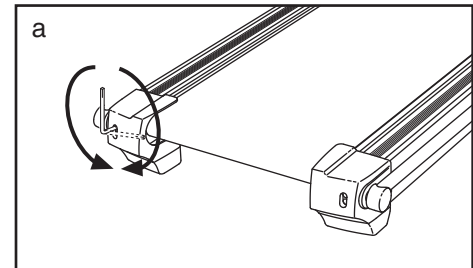

b. If the walking belt slips when walked on, first remove the key and **UNPLUG THE POWER CORD**. Using the allen wrench, turn both rear roller bolts clockwise 1/4 of a turn. When the walking belt is correctly tightened, you should be able to lift each side of the walking belt 3 to 4 inches off the walking platform. Be careful to keep the walking belt centered. Plug in the power cord, insert the key, and walk on the treadmill for a few minutes. Repeat until the walking belt is properly tightened.

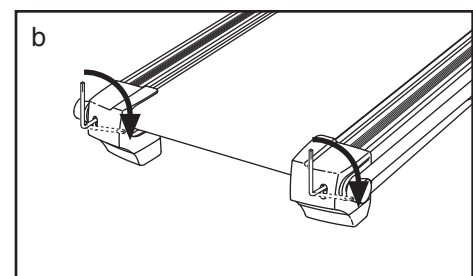

PROBLEM: The upper body arms come off, do not slide easily, or make a squeaking noise

SOLUTION: a. See UPPER BODY ARM TROUBLESHOOTING on page 24.

EXERCISE GUIDELINES

⚠️ WARNING: Before beginning this or any exercise program, consult your physician. This is especially important for individuals over the age of 35 or individuals with pre-existing health problems.

The pulse sensor is not a medical device. Various factors, including the user's movement, may affect the accuracy of heart rate readings. The pulse sensor is intended only as an exercise aid in determining heart rate trends in general.

The following guidelines will help you to plan your exercise program. For more detailed exercise information, obtain a reputable book or consult your physician.

EXERCISE INTENSITY

Whether your goal is to burn fat or to strengthen your cardiovascular system, the key to achieving the desired results is to exercise with the proper intensity. The proper intensity level can be found by using your heart rate as a guide. The chart below shows recommended heart rates for fat burning and aerobic exercise.

HEART RATE TRAINING ZONES							
AEROBIC	165	155	145	140	130	125	115
MAX FAT BURN	145	138	130	125	118	110	103
FAT BURN	125	120	115	110	105	95	90
Age	20	30	40	50	60	70	80

To find the proper heart rate for you, first find your age near the bottom of the chart (ages are rounded off to the nearest ten years). Next, find the three numbers above your age. The three numbers define your “training zone.” The lower two numbers are recommended heart rates for fat burning; the highest number is the recommended heart rate for aerobic exercise.

To measure your heart rate during exercise, use the handgrip pulse sensor.

Fat Burning

To burn fat effectively, you must exercise at a relatively low intensity level for a sustained period of time. During the first few minutes of exercise, your body uses easily accessible *carbohydrate calories* for en-

ergy. Only after the first few minutes does your body begin to use stored *fat calories* for energy. If your goal is to burn fat, adjust the speed or incline of the treadmill until your heart rate is near the lowest number in your training zone.

For maximum fat burning, adjust the speed or incline of the treadmill until your heart rate is near the middle number in your training zone.

Aerobic Exercise

If your goal is to strengthen your cardiovascular system, your exercise must be “aerobic.” Aerobic exercise is activity that requires large amounts of oxygen for prolonged periods of time. This increases the demand on the heart to pump blood to the muscles, and on the lungs to oxygenate the blood. For aerobic exercise, adjust the speed or incline of the treadmill until your heart rate is near the highest number in your training zone.

WORKOUT GUIDELINES

Each workout should include the following three parts:

A Warm-up—Start each workout with 5 to 10 minutes of stretching and light exercise. A proper warm-up increases your body temperature, heart rate and circulation in preparation for exercise.

Training Zone Exercise—After warming up, increase the intensity of your exercise until your pulse is in your training zone for 20 to 60 minutes. (During the first few weeks of your exercise program, do not keep your pulse in your training zone for longer than 20 minutes.) Breathe regularly and deeply as you exercise—never hold your breath.

A Cool-down—Finish each workout with 5 to 10 minutes of stretching to cool down. This will increase the flexibility of your muscles and will help prevent post-exercise problems.

EXERCISE FREQUENCY

To maintain or improve your condition, complete three workouts each week, with at least one day of rest between workouts. After a few months, you may complete up to five workouts each week if desired. The key to success is to make exercise a regular and enjoyable part of your everyday life.

PART LIST—Model No. PFTL61931

R0304A

To locate the parts listed below, see the EXPLODED DRAWING attached in the center of this manual.

Key No.	Qty.	Description	Key No.	Qty.	Description
1	2	Foot Rail Base	51	1	Right Front Endcap
2	1	Left Foot Rail	52	1	Walking Belt
3	1	Left Front Endcap	53	1	Walking Platform
4	2	Belt Guide	54	1	Frame
5	4	Belt Guide Screw	55	1	Belly Pan Clip
6	45	3/4" Screw	56	2	Caution Decal
7	2	Ball Joint	57	1	Rear Roller
8	2	Ball Joint Nut	58	1	Right Rear Foot
9	2	Catch Screw	59	1	Allen Wrench
10	1	Warning Deal	60	2	Rear Roller Adj. Bolt
11	2	Rear Platform Bolt	61	2	Rear Roller Washer
12	2	Latch Catch	62	1	Right Rear Endcap
13	1	Left Pole Housing	63	1	Left Rear Foot
14	1	Right Pole Housing	64	1	Left Rear Endcap
15	2	Red Isolator	65	1	iFIT.com Jack
16	4	Platform Screw	66*	2	Extension Leg Assembly
17	2	Platform Pivot Bolt	67	4	Front Endcap Screw
18	1	Magnet	68	1	Left Handrail
19	2	Housing Screw	69	14	3/4" Tek Screw
20	1	Motor Pivot Bolt	70	1	Latch Knob
21	7	Nut	71	2	1" Bolt
22	2	Frame Spacer	72	4	Internal Washer
23	1	Reed Switch Clip	73	1	Left Handrail Bracket
24	1	Reed Switch	74*	1	Latch Assembly
25	10	1" Tek Screw	75	2	Lift Frame Pivot Bolt
26	1	Lift Frame	76	1	Latch Housing
27	1	Motor Tension Nut	77	2	Upper Body Arm Holder
28	1	Motor	78	1	Controller Bracket
29	1	Pulley/Flywheel/Fan	79	1	Incline Motor Bolt (Lower)
30	1	Motor Belt	80	11	Isolator Screw/Endcap Screw
31*	1	Motor Assembly	81	1	Right Handrail
32	1	Motor Tension Bolt	82	1	Upright
33	1	Motor Tension Washer	83	1	Wire Harness
34	1	Motor Star Washer	84	1	Left Accessory Tray
35	2	Upper Body Arm	85	1	Console Base
36	7	Small Screw	86	4	Fan Screw
37	1	Ground Wire	87	1	Fan
38	1	Transformer	88	1	Console
39	1	Hood	89	1	Fan Housing
40	1	Controller	90	1	Right Accessory Tray
41	1	Power Cord	91	1	Key/Clip
42	1	IFIT.com Wire Nut	92	2	1 1/4" Screw
43	1	IFIT.com Wire	93	2	2" Silver Screw
44	1	Power Cord Grommet	94	1	Access Door
45	2	Static Decal	95	1	Console Back
46	1	Reset/Off Switch	96	3	Tie Holder
47	3	Belly Pan Screw	97	1	Releasable Tie
48	1	Belly Pan	98	1	Plastic Tie
49	1	Hole Plug	99	2	Upright Endcap
50	1	Filter Wire	100	8	Base Pad

Key No.	Qty.	Description	Key No.	Qty.	Description
101	1	Motor Lock Nut	115	1	Front Roller Adj. Bolt
102	1	Incline Plate	116	1	iFIT.com Cable
103	2	Black Isolator	117	2	1" Screw
104	1	Pulse Bar	#	1	4" Blue Wire, 2 F
105	1	Pulse Wire	#	1	4" Black Wire, M/F
106	2	Extension Leg	#	1	4" Red Wire, M/F
107	2	Wheel Bolt	#	1	10" White Wire, 2 F
108	2	Wheel	#	1	User's Manual
109	2	Roller Star Washer			
110	2	iFIT.com CD			
111	2	Incline Motor Bolt			
112	1	Incline Motor			
113	1	Right Handrail Bracket			
114	1	Front Roller/Pulley			

* Includes all parts shown in the box

These parts are not illustrated

Specifications are subject to change without notice.

EXPLODED DRAWING—Model No. PFTL61931

R0304A

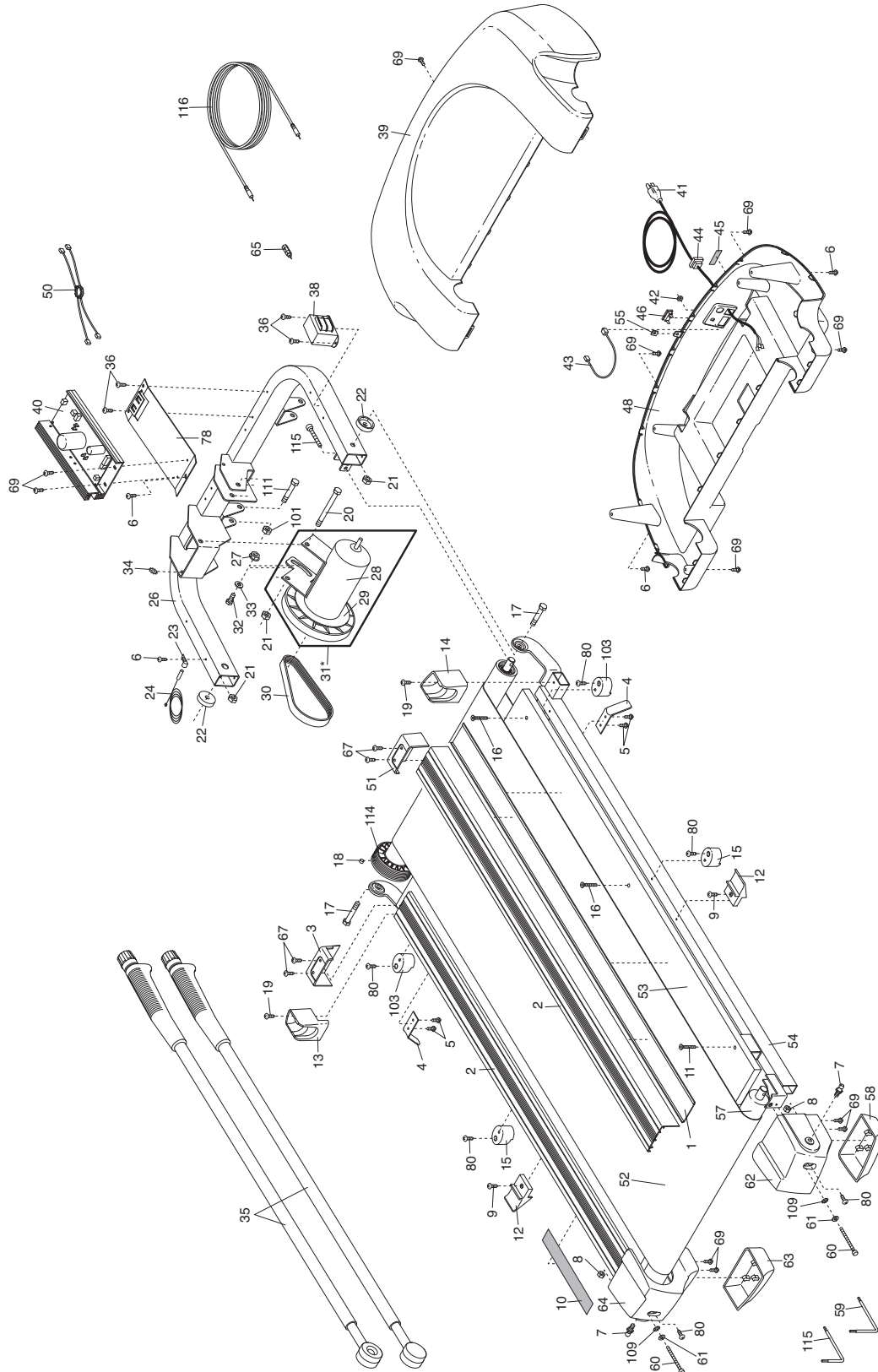

To identify the parts shown on this EXPLODED DRAWING, see the PART LIST on pages 30 and 31 of the user's manual.

EXPLODED DRAWING—Model No. PFTL61931

R0304A

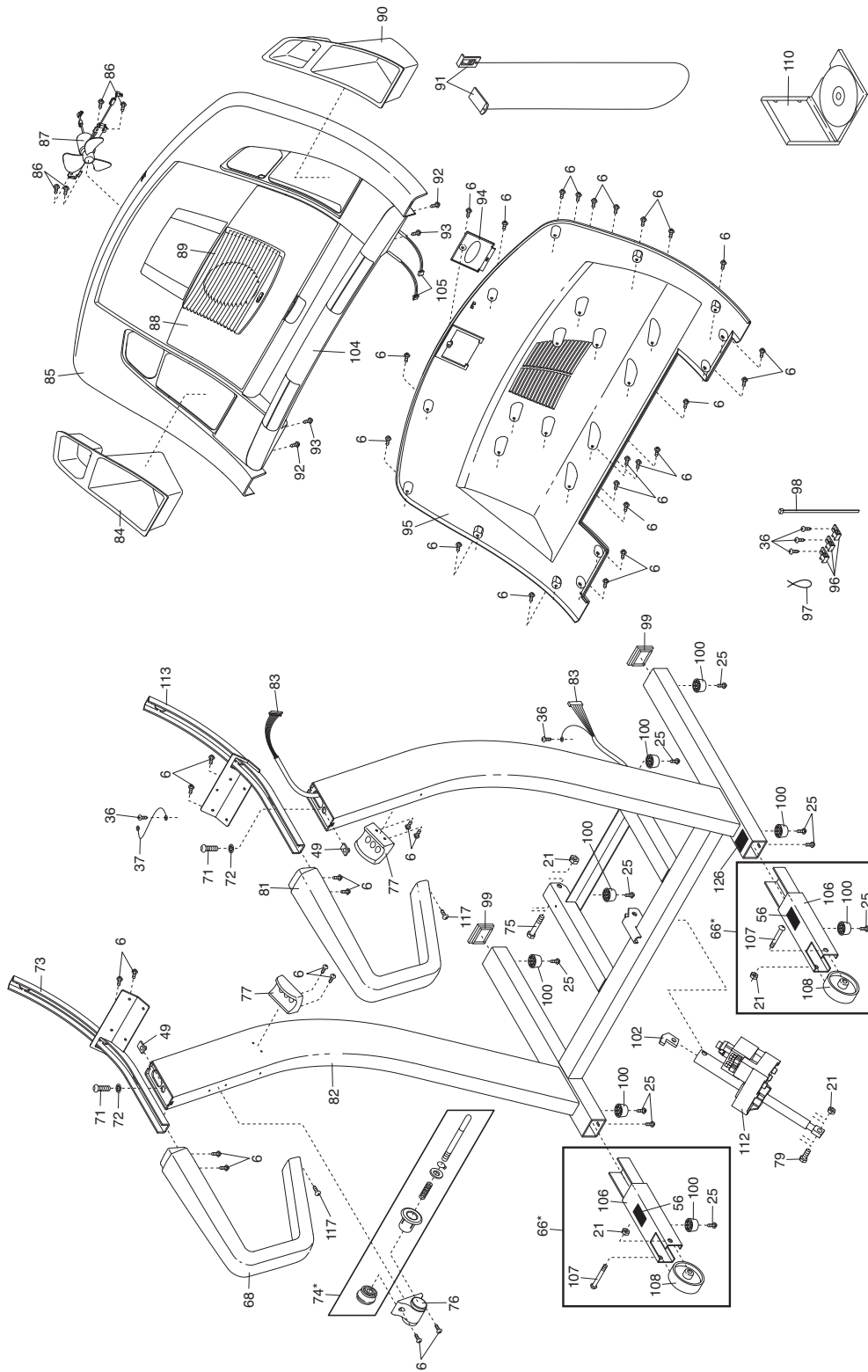

ORDERING REPLACEMENT PARTS

To order replacement parts, call our Customer Service Department toll-free at 1-888-533-1333, Monday through Friday, 6 a.m. until 6 p.m. Mountain Time (excluding holidays). When ordering parts, please be prepared to give the following information:

- The MODEL NUMBER of the product (PFTL61931)
- The NAME of the product (PROFORM® CROSSWALK ADVANCED CR treadmill)
- The SERIAL NUMBER of the product (see the front cover of this manual)
- The KEY NUMBER and DESCRIPTION of the desired part(s) (see the PART LIST on pages 30 and 31 and the EXPLODED DRAWING in the center of this manual)

LIMITED WARRANTY

ICON Health & Fitness, Inc. (ICON), warrants this product to be free from defects in workmanship and material, under normal use and service conditions, for a period of ninety (90) days from the date of purchase. This warranty extends only to the original purchaser. ICON's obligation under this warranty is limited to replacing or repairing, at ICON's option, the product through one of its authorized service centers. All repairs for which warranty claims are made must be pre-authorized by ICON. This warranty does not extend to any product or damage to a product caused by or attributable to freight damage, abuse, misuse, improper or abnormal usage or repairs not provided by an ICON authorized service center; products used for commercial or rental purposes; or products used as store display models. No other warranty beyond that specifically set forth above is authorized by ICON.

ICON is not responsible or liable for indirect, special or consequential damages arising out of or in connection with the use or performance of the product or damages with respect to any economic loss, loss of property, loss of revenues or profits, loss of enjoyment or use, costs of removal or installation or other consequential damages of whatsoever nature. Some states do not allow the exclusion or limitation of incidental or consequential damages. Accordingly, the above limitation may not apply to you.

The warranty extended hereunder is in lieu of any and all other warranties and any implied warranties of merchantability or fitness for a particular purpose is limited in its scope and duration to the terms set forth herein. Some states do not allow limitations on how long an implied warranty lasts. Accordingly, the above limitation may not apply to you.

This warranty gives you specific legal rights. You may also have other rights which vary from state to state.

ICON HEALTH & FITNESS, INC., 1500 S. 1000 W., LOGAN, UT 84321-9813