

PRO-FORM® 400 GL+ Clear-View™ Backlit Console

Model No. PFTL68505.1

Serial No. _____

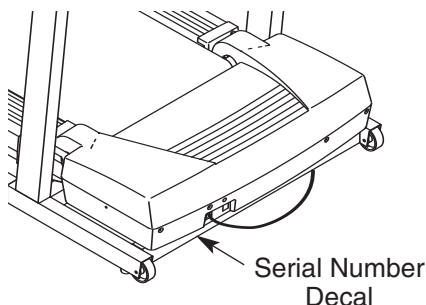

USER'S MANUAL

QUESTIONS?

As a manufacturer, we are committed to providing complete customer satisfaction. If you have questions, or if parts are damaged or missing, PLEASE CONTACT OUR CUSTOMER SERVICE DEPARTMENT DIRECTLY.

CALL TOLL-FREE:

1-888-533-1333

Mon.–Fri. 6 a.m.–6 p.m. MST

Sat. 8 a.m.–5 p.m. MST

ON THE WEB:

www.proformservice.com

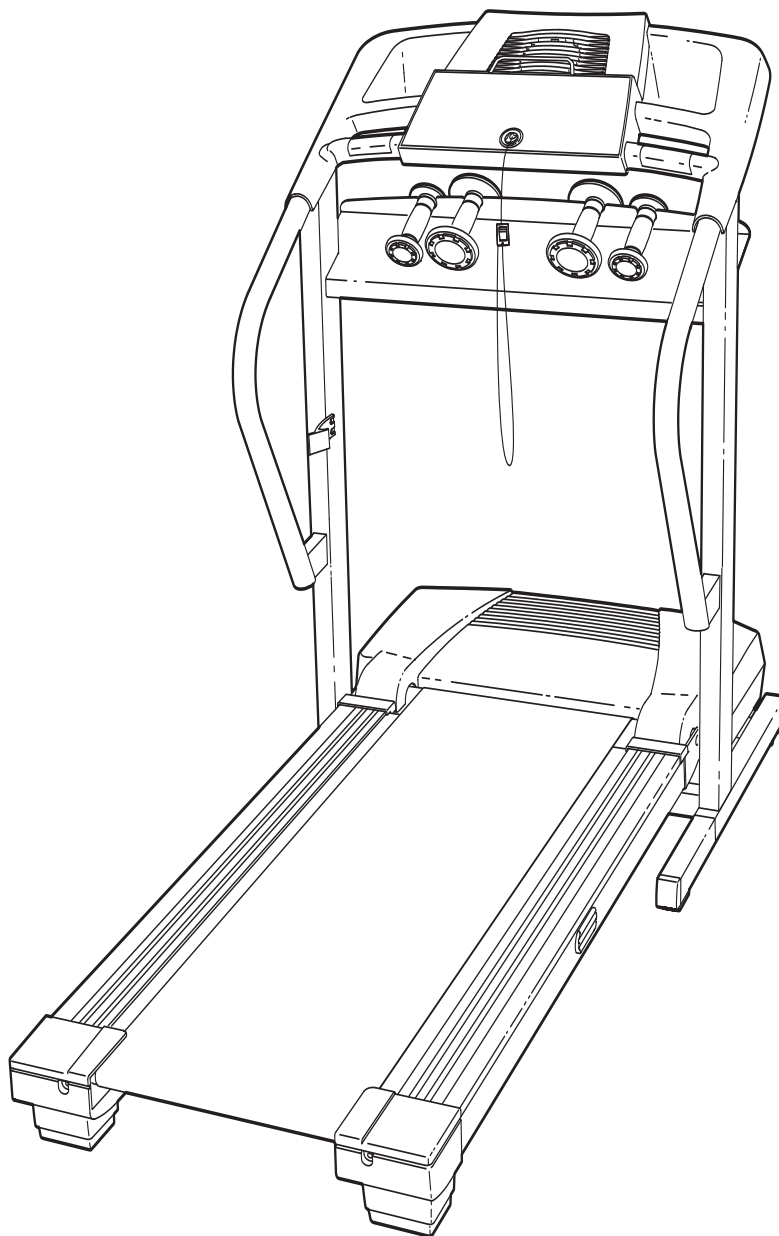

CAUTION

Read all precautions and instructions in this manual before using this equipment. Save this manual for future reference.



Visit our website at

www.proform.com

new products, prizes,
fitness tips, and much more!

PRO-FORM® 400 GL+ Clear-View™ Backlit Console

TABLE OF CONTENTS

IMPORTANT PRECAUTIONS	3
BEFORE YOU BEGIN	5
ASSEMBLY	6
OPERATION AND ADJUSTMENT	10
HOW TO FOLD AND MOVE THE TREADMILL	23
TROUBLESHOOTING	25
CONDITIONING GUIDELINES	27
ORDERING REPLACEMENT PARTSBack Cover
LIMITED WARRANTYBack Cover

Note: An EXPLODED DRAWING and a PART LIST are attached in the center of this manual.

IMPORTANT PRECAUTIONS

⚠ WARNING: To reduce the risk of burns, fire, electric shock, or injury to persons, read the following important precautions and information before operating the treadmill.

1. It is the responsibility of the owner to ensure that all users of this treadmill are adequately informed of all warnings and precautions.
2. Use the treadmill only as described.
3. Place the treadmill on a level surface, with at least eight feet of clearance behind it and two feet on each side. Do not place the treadmill on any surface that blocks air openings. To protect the floor or carpet from damage, place a mat under the treadmill.
4. Keep the treadmill indoors, away from moisture and dust. Do not put the treadmill in a garage or covered patio, or near water.
5. Do not operate the treadmill where aerosol products are used or where oxygen is being administered.
6. Keep children under the age of 12 and pets away from the treadmill at all times.
7. The treadmill should be used only by persons weighing 300 pounds or less.
8. Never allow more than one person on the treadmill at a time.
9. Wear appropriate exercise clothes when using the treadmill. Do not wear loose clothes that could become caught in the treadmill. Athletic support clothes are recommended for both men and women. *Always wear athletic shoes. Never use the treadmill with bare feet, wearing only stockings, or in sandals.*
10. When connecting the power cord (see page 10), plug the power cord into a surge suppressor (not included) and plug the surge suppressor into a grounded circuit capable of carrying 15 or more amps. No other appliance should be on the same circuit. Do not use an extension cord.
11. Use only a single-outlet surge suppressor that meets all of the specifications described on page 10. To purchase a surge suppressor, see your local PROFORM dealer or call the toll-free telephone number on the front cover of this manual and order part number 146148, or see your local electronics store.
12. Failure to use a properly functioning surge suppressor could result in damage to the control system of the treadmill. If the control system is damaged, the walking belt may change speed, accelerate, or stop unexpectedly, which may result in a fall and serious injury.
13. Keep the power cord and the surge suppressor away from heated surfaces.
14. Never move the walking belt while the power is turned off. Do not operate the treadmill if the power cord or plug is damaged, or if the treadmill is not working properly. (See BEFORE YOU BEGIN on page 5 if the treadmill is not working properly.)
15. Read, understand, and test the emergency stop procedure before using the treadmill (see HOW TO TURN ON THE POWER on page 12).
16. Never start the treadmill while you are standing on the walking belt. Always hold the handrails while using the treadmill.
17. The treadmill is capable of high speeds. Adjust the speed in small increments to avoid sudden jumps in speed.
18. The pulse sensor is not a medical device. Various factors, including your movement, may affect the accuracy of heart rate readings. The sensor is intended only as an exercise aid in determining heart rate trends in general.
19. Do not use the hand weights at speeds faster than walking speeds. Using weights and not holding the handrails may compromise your ability to maintain your balance. Exercises using weights should be attempted only by experienced users.
20. Never leave the treadmill unattended while it is running. Always remove the key and unplug the power cord when the treadmill is not in use.
21. Do not attempt to raise, lower, or move the treadmill until it is properly assembled. (See ASSEMBLY on page 6, and HOW TO FOLD AND MOVE THE TREADMILL on page 23.) You must be able to safely lift 45 pounds (20 kg) to raise, lower, or move the treadmill.
22. When folding or moving the treadmill, make sure that the storage latch is fully closed.

23. When using iFIT.com programs, an electronic “chirping” sound will alert you when the speed and/or incline of the treadmill is about to change. Always listen for the “chirp” and be prepared. In some instances, the speed and/or incline may change before the personal trainer describes the change.

24. When using iFIT.com programs, you can manually override the speed and incline settings by pressing the speed and incline buttons. However, when the next “chirp” is heard, the speed and/or incline will change to the next settings of the program.

25. Remove iFIT.com CDs and videos from your CD player and VCR and disconnect your MP3 player when you are not using them.

26. Inspect and properly tighten all parts of the treadmill regularly.

27. Never insert any object into any opening.

28. **DANGER:** Always unplug the power cord immediately after use, before cleaning the treadmill, and before performing the maintenance and adjustment procedures described in this manual. Never remove the motor hood unless instructed to do so by an authorized service representative. Servicing other than the procedures in this manual should be performed by an authorized service representative only.

29. This treadmill is intended for in-home use only. Do not use this treadmill in a commercial, rental, or institutional setting.

⚠ WARNING: Before beginning this or any exercise program, consult your physician. This is especially important for persons over the age of 35 or persons with pre-existing health problems. Read all instructions before using. ICON assumes no responsibility for personal injury or property damage sustained by or through the use of this product.

SAVE THESE INSTRUCTIONS

The decals shown here have been placed on the treadmill. If a decal is missing, or if it is not legible, call the toll-free telephone number on the front cover of this manual and order a free replacement decal. Apply the decal in the location shown.

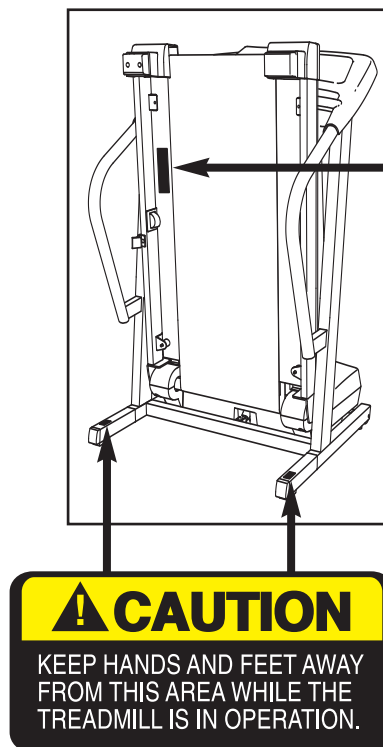

⚠ WARNING:
Protect yourself and others from risk of serious injury. Read the user's manual and :

-  •Stand only on the side rails when starting or stopping treadmill.
- Change speed in small increments.
- Hold handrails to prevent falling, and always wear the safety clip while operating treadmill.
- Stop if you feel faint, dizzy, or short of breath.
- Fully engage storage latch before treadmill is moved or stored.
- Reduce incline to its lowest level before folding treadmill into storage position.

-  •Never allow children on or around treadmill.
- Remove key when not in use.

-  •Keep clothing, fingers, and hair away from moving belt.
- Never try to adjust or fix the belt while it is moving.
- Always wear athletic shoes while operating treadmill.

BEFORE YOU BEGIN

Thank you for selecting the new PROFORM® 400 GL+ treadmill. The 400 GL+ treadmill combines advanced technology with innovative design to help you get the most from your exercise in the convenience of your home. And when you're not exercising, the 400 GL+ treadmill can be folded up, requiring less than half the floor space of other treadmills.

For your benefit, read this manual carefully before you use the treadmill. If you have questions after reading this manual, please see the front cover of this manual. To help us assist you, note the product model

number and serial number before calling. The model number of the treadmill is PFTL68505.1. The serial number can be found on a decal attached to the treadmill (see the front cover of this manual for the location).

To avoid a registration fee for any service needed under warranty, you must register the treadmill at www.proformservice.com/registration.

Before reading further, please review the drawing below and familiarize yourself with the labeled parts.

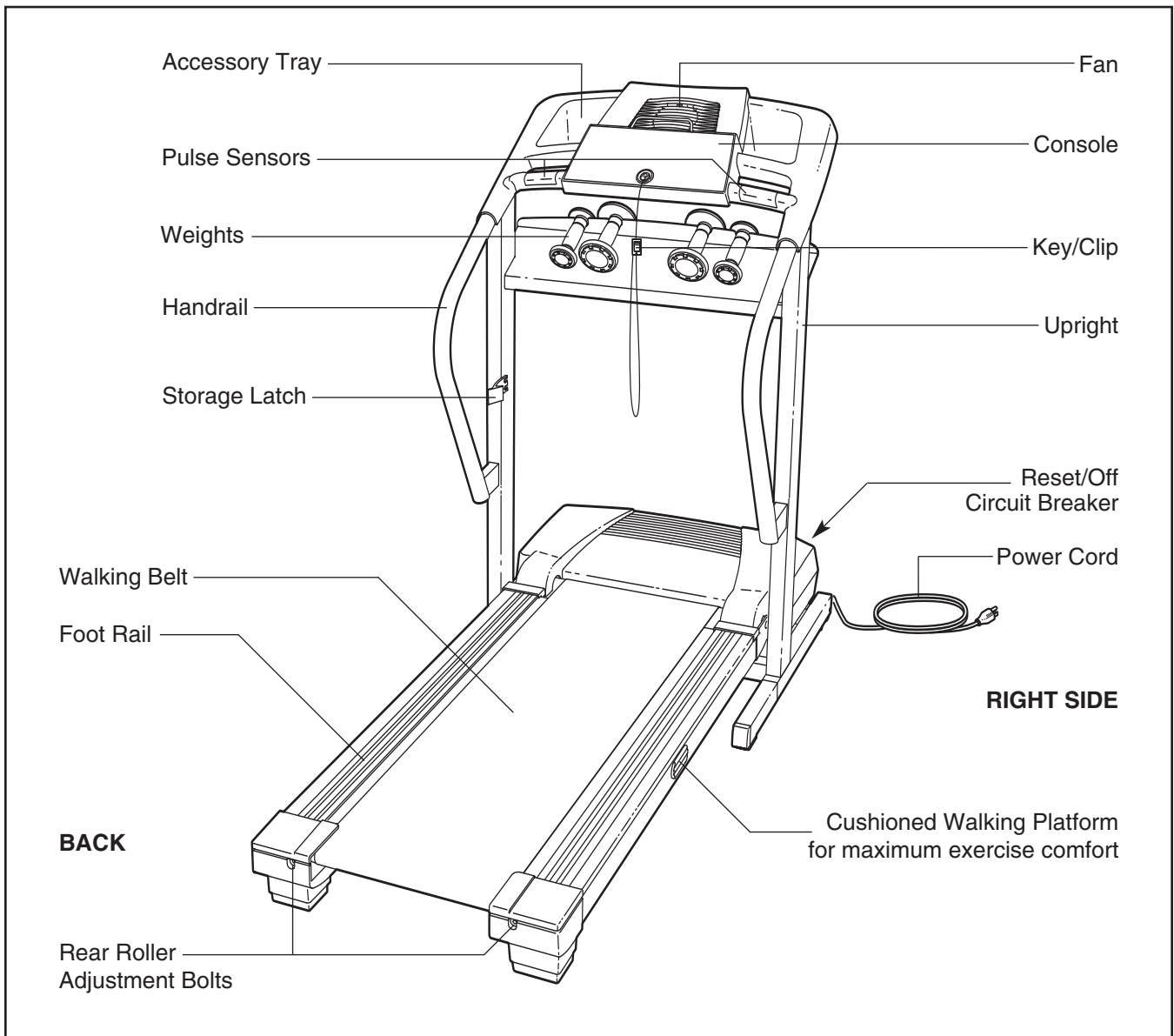

ASSEMBLY

To hire an authorized service technician to assemble the treadmill, call toll-free 1-800-445-2480.

Assembly requires two persons. Set the treadmill in a cleared area and remove all packing materials. Do not dispose of the packing materials until assembly is completed. Note: The underside of the treadmill walking belt is coated with high-performance lubricant. During shipping, a small amount of lubricant may be transferred to the top of the walking belt or the shipping carton. This is a normal condition and does not affect treadmill performance. If there is lubricant on top of the walking belt, simply wipe off the lubricant with a soft cloth and a mild, non-abrasive cleaner.

Assembly requires the included hex keys  **and your own phillips screwdriver** , **rubber mallet** , **and adjustable wrench** .

For help identifying the assembly hardware, see the drawings below. If a part is not in the parts bag, first check to see if it has been pre-assembled. **To avoid damaging plastic parts, do not use power tools for assembly.**

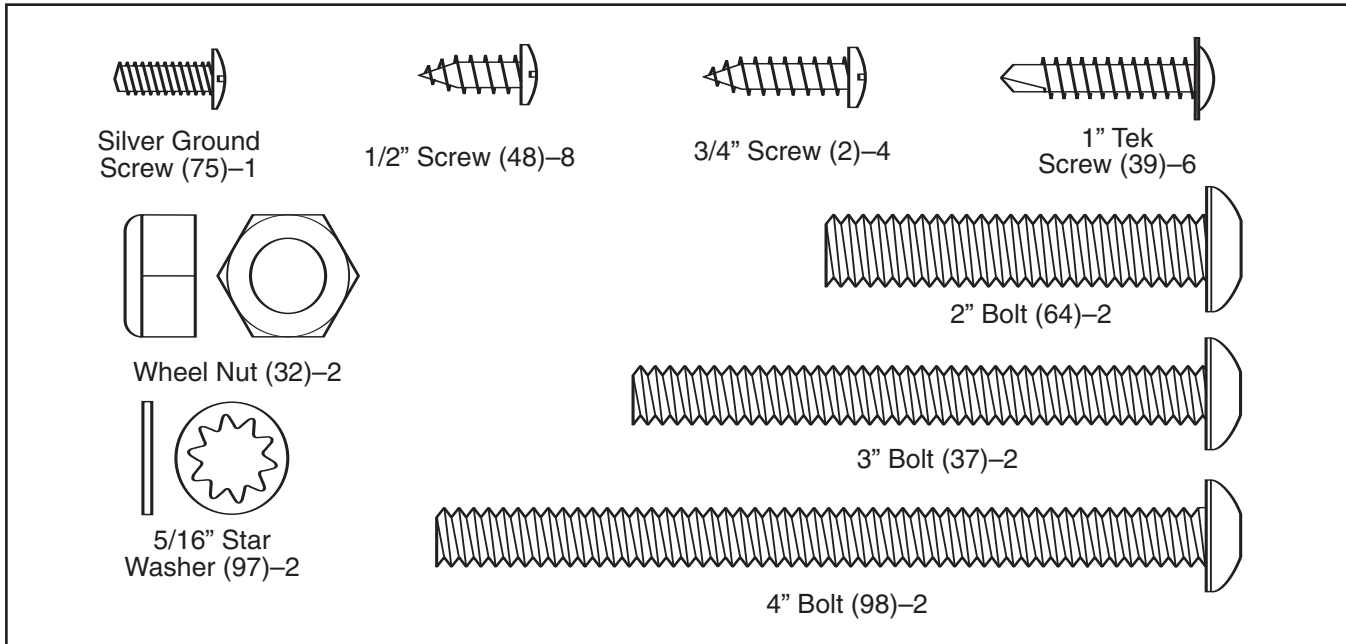

1. Make sure that the power cord is unplugged.

With the help of another person, carefully raise the Uprights (69) to the vertical position. Insert one of the Extension Legs (63) into the treadmill as shown. (Note: It may be helpful to tip the Uprights as you insert the Extension Leg.) Make sure that the Extension Leg Pad (61) is under the Extension Leg.

Insert the other Extension Leg (63) in the same way.

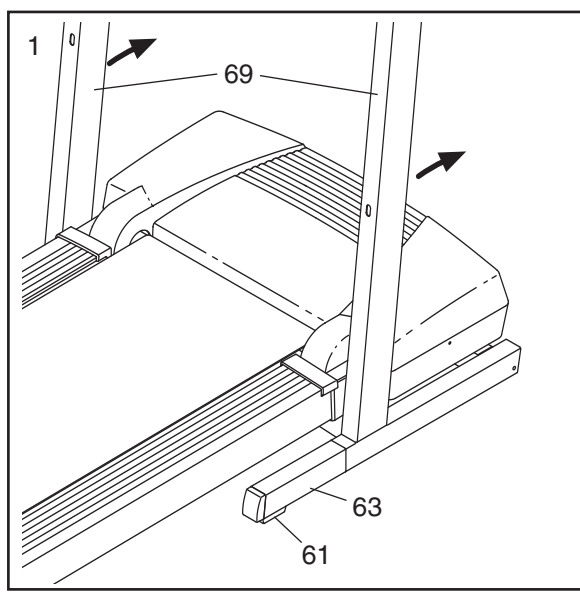

- Cut any ties holding the Upright Wire (42) to the the right Upright (69).

Identify the Right Handrail (72), which has a large hole in the left side. Feed the Upright Wire (42) into the hole in the bottom of the Right Handrail and out of the large hole in the side. Note: It may be helpful to use needlenose pliers to pull the Wire Harness out of the hole.

Attach the upper end of the Right Handrail (72) to the right Upright (69) with a 3" Bolt (37). **Do not tighten the Bolt yet.** Attach the lower end of the Right Handrail with a 4" Bolt (98) and a 5/16" Star Washer (97). **Firmly tighten the 3" Bolt and 4" Bolt.**

Attach the upper end of the Left Handrail (71) to the left Upright (69) with a 3" Bolt (37). Note: There is not a wire harness on the left side. **Do not tighten the Bolt yet.** Attach the lower end of the Left Handrail with a 4" Bolt (98) and a 5/16" Star Washer (97). **Firmly tighten the 3" Bolt and 4" Bolt.**

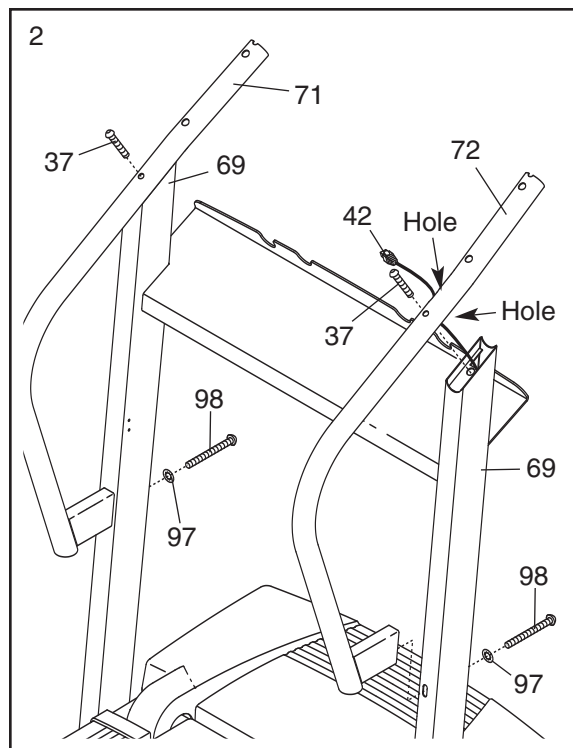

- With the help of another person, carefully lower the Uprights (69) as shown. Note: It may be helpful to place one foot on one of the Extension Legs (63) as you tip the Uprights. **Make sure that the Extension Legs remain in the Uprights.**

Attach each Extension Leg (63) with two 1" Tek Screws (39) and a Base Pad (57) as shown. **Attach the lower Tek Screw, without the Base Pad, first.**

Attach two Base Pads (57) to the base of the Uprights (69) with two 1" Tek Screws (39).

Attach the two Wheels (66) with two 2" Bolts (64) and two Wheel Nuts (32) as shown. **Do not overtighten the Bolts;** the Wheels should turn freely.

With the help of another person, carefully raise the Uprights (69) to the vertical position.

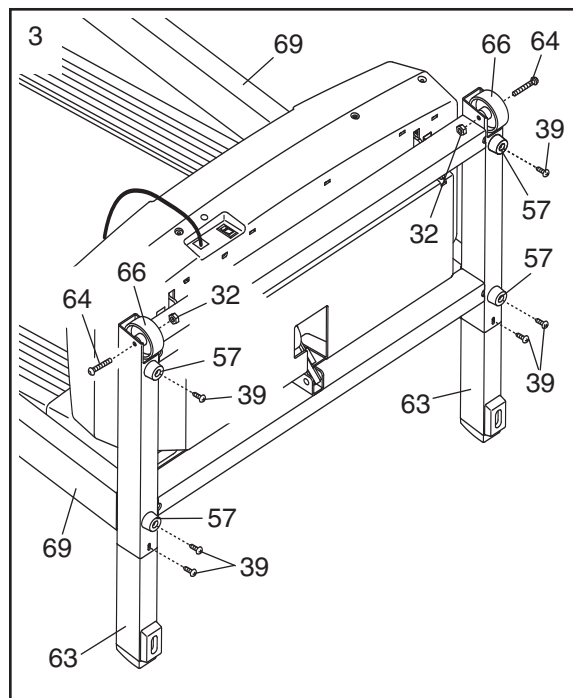

4. Hold the Console Base (47) near the Left Handrail (71). Attach the ends of the ground wires on the Console Base to the indicated small hole in the Left Handrail with the Silver Ground Screw (75).

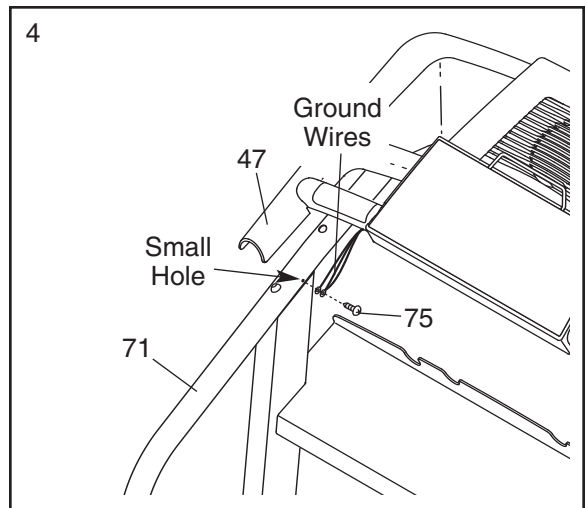

5. **Touch the Right Handrail (72) to discharge any static.** Slide the sleeve off the connector as shown in the inset drawing. Press the end of the Upright Wire (42) into the socket in the bottom of the Console Base (47). **The connector should slide easily into the socket and snap into place.** If the connector does not slide easily and snap into place, turn the connector and then insert it. Slide the sleeve back over the connector.

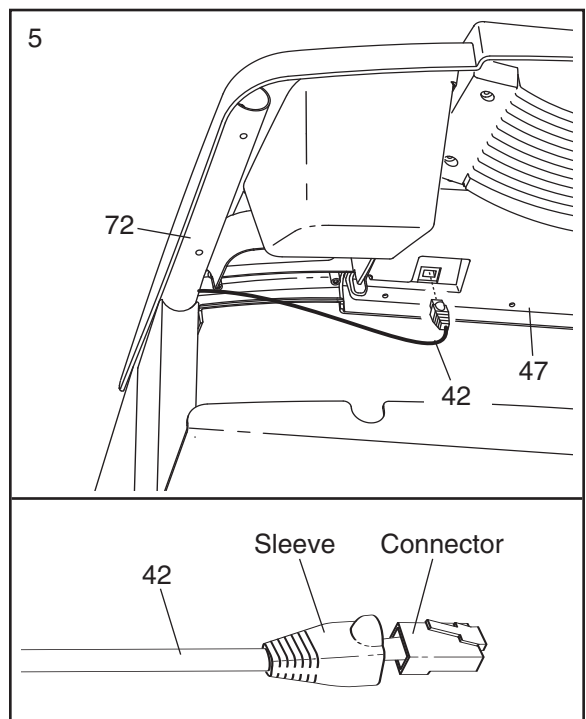

6. Set the Console Base (47) on the Right Handrail (72) and the Left Handrail (71). Attach the Console Base with four 1/2" Screws (48). **Start all four Screws before tightening them; do not overtighten the Screws.**

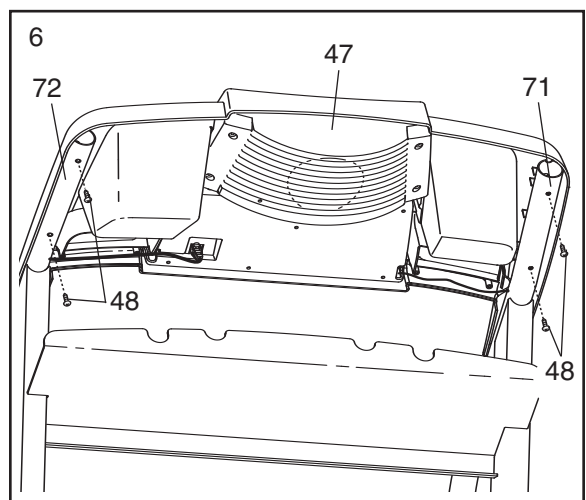

7. Press the Upright Wire (42) into the slot in the underside of the Console Base (47) in the indicated area. Cover the Upright Wire with the Right Grip Plate (36). **Be careful not to pinch the Upright Wire.** Tighten two 1/2" Screws (48) and a 3/4" Screw (2) into the Right Grip Plate and the Console Base.

Attach the Left Grip Plate (34) over the ground wire and the other wires with two 1/2" Screws (48) and a 3/4" Screw (2). **Be careful not to pinch any of the wires.**

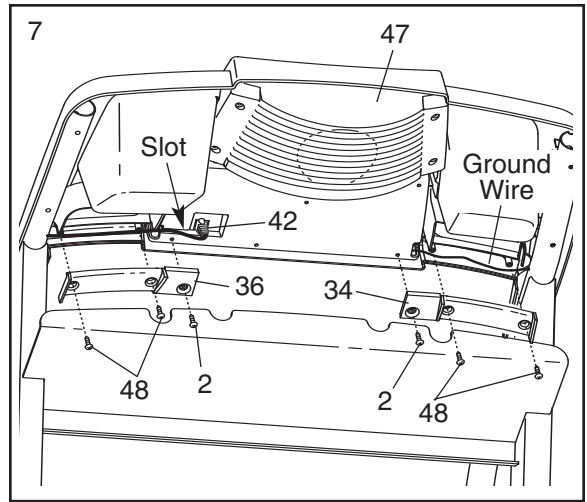

8. Attach the Storage Latch (29) and the Latch Spacer (44) to the left Upright (69) with two 3/4" Screws (2) as shown. **Do not overtighten the Screws.**

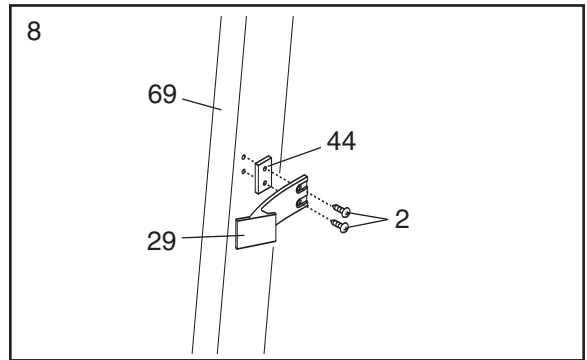

9. Set the 2-pound Weights (9) and the 3-pound Weights (102) on the weight rack as shown.

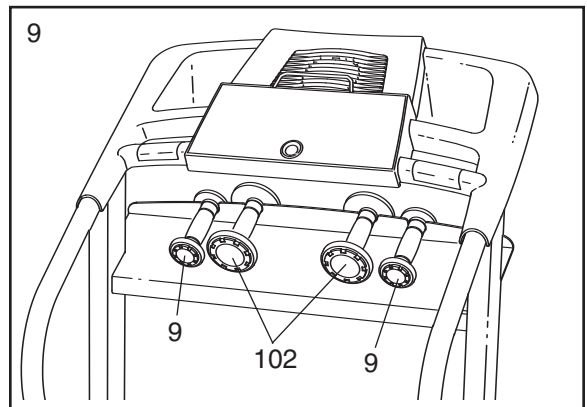

10. **Make sure that all parts are properly tightened before you use the treadmill.** Note: Extra hardware may be included. Keep the included hex keys in a secure place; the large hex key is used to adjust the walking belt (see page 26). To protect the floor or carpet, place a mat under the treadmill.

OPERATION AND ADJUSTMENT

THE PRE-LUBRICATED WALKING BELT

Your treadmill features a walking belt coated with high-performance lubricant. **IMPORTANT: Never apply silicone spray or other substances to the walking belt or the walking platform.** Such substances will deteriorate the walking belt and cause excessive wear.

HOW TO PLUG IN THE POWER CORD

⚠ DANGER: Improper connection of the equipment-grounding conductor can result in an increased risk of electric shock. Check with a qualified electrician or serviceman if you are in doubt as to whether the product is properly grounded. Do not modify the plug provided with the product—if it will not fit the outlet, have a proper outlet installed by a qualified electrician.

Your treadmill, like any other type of sophisticated electronic equipment, can be seriously damaged by sudden voltage changes in your home's power. Voltage surges, spikes, and noise interference can result from weather conditions or from other appliances being turned on or off. **To decrease the possibility of your treadmill being damaged, always use a surge suppressor with your treadmill (see drawing 1 at the right).** To purchase a surge suppressor, see your local PROFORM dealer or call the toll-free telephone number on the front cover of this manual and order part number 146148, or see your local electronics store.

Use only a single-outlet surge suppressor that is UL 1449 listed as a transient voltage surge suppressor (TVSS). The surge suppressor must have a UL suppressed voltage rating of 400 volts or less and a minimum surge dissipation of 450 joules. The surge suppressor must be electrically rated for 120 volts AC and 15 amps. There must be a monitoring light on the surge suppressor to indicate whether it is functioning properly. Failure to use a properly functioning surge suppressor could result in damage to the control system of the treadmill. If the control system is damaged, the walking belt may change speed, accelerate or stop unexpectedly, which may result in a fall and serious injury.

This product must be grounded. If it should malfunction or break down, grounding provides a path of least resistance for electric current to reduce the risk of elec-

tric shock. This product is equipped with a cord having an equipment-grounding conductor and a grounding plug. **Plug the power cord into a surge suppressor, and plug the surge suppressor into an appropriate outlet that is properly installed and grounded in accordance with all local codes and ordinances. Important: The treadmill is not compatible with GFCI-equipped outlets.**

This product is for use on a nominal 120-volt circuit, and has a grounding plug that looks like the plug illustrated in drawing 1 below. A temporary adapter that looks like the adapter illustrated in drawing 2 may be used to connect the surge suppressor to a 2-pole receptacle as shown in drawing 2 if a properly grounded outlet is not available.

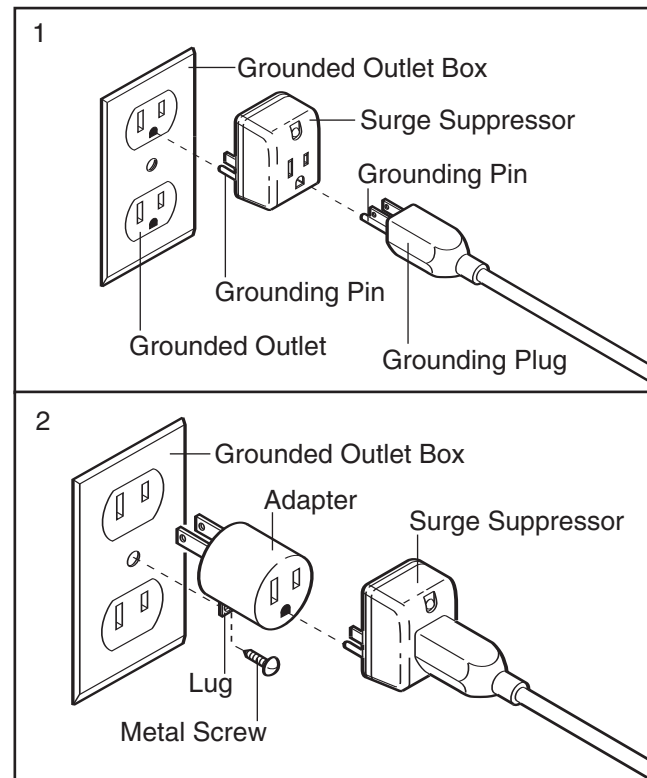

The temporary adapter should be used only until a properly grounded outlet (drawing 1) can be installed by a qualified electrician.

The green-colored rigid ear, lug, or the like extending from the adapter must be connected to a permanent ground such as a properly grounded outlet box cover. Whenever the adapter is used it must be held in place by a metal screw. **Some 2-pole receptacle outlet box covers are not grounded. Contact a qualified electrician to determine if the outlet box cover is grounded before using an adapter.**

CONSOLE DIAGRAM

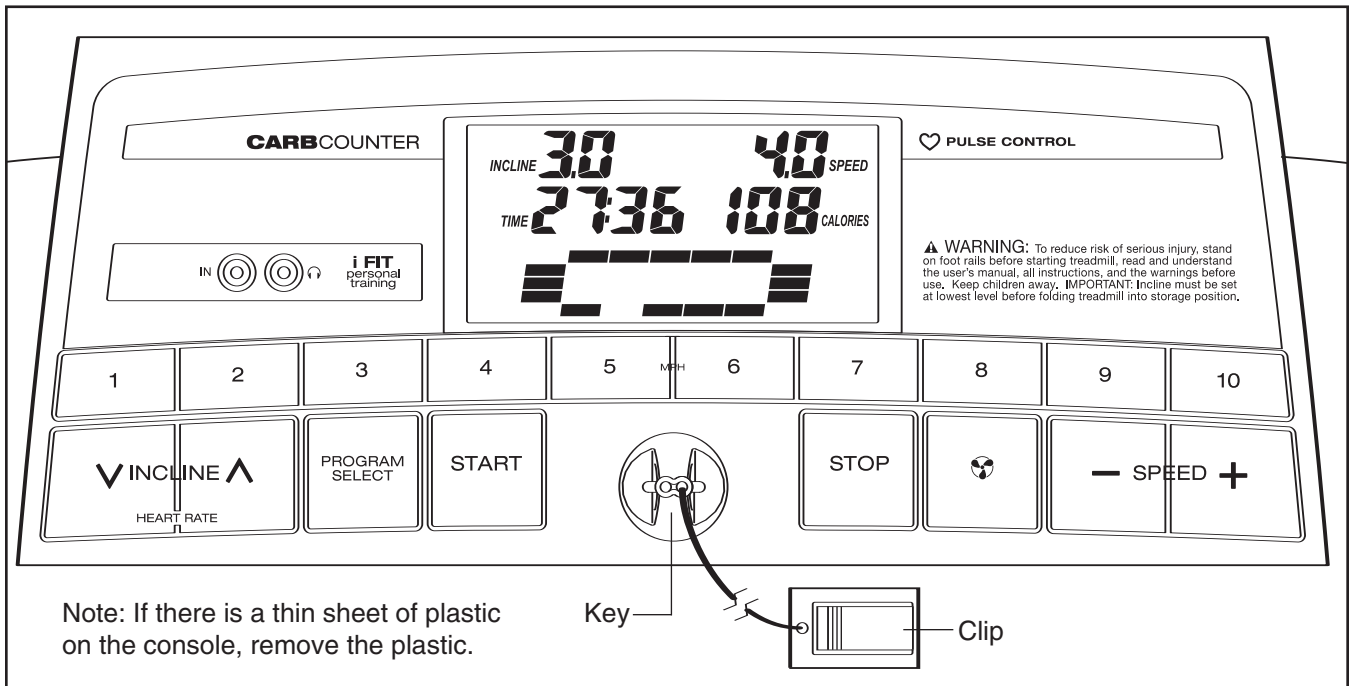

FEATURES OF THE CONSOLE

The treadmill console offers an impressive array of features designed to help you get the most from your workouts.

When the manual mode of the console is selected, the speed and incline of the treadmill can be changed with the touch of a button. As you exercise, the console will display continuous exercise feedback. You can even measure your heart rate using the built-in handgrip pulse sensor.

In addition, the console features four preset programs. Each program automatically controls the speed and incline of the treadmill to give you an effective workout. The console also offers two heart rate programs that control the speed and incline of the treadmill to keep your heart rate near a target heart rate during your workouts.

The console also features iFIT.com interactive technology. Having iFIT.com technology is like having a personal trainer in your home. Using a stereo audio cable,

you can connect the treadmill to your portable stereo, home stereo, computer, or VCR and play special iFIT.com MP3, CD, and video programs (iFIT.com MP3 programs, CDs, and videocassettes are available separately). iFIT.com programs automatically control the speed and incline of the treadmill as a personal trainer guides you through every step of your workout; high-energy music provides added motivation. **To download iFIT.com MP3 programs, go to www.iFIT.com. To purchase iFIT.com CDs or videocassettes, call the toll-free telephone number on the front cover of this manual.**

With the treadmill connected to your computer, you can also go to www.iFIT.com and access iFIT.com programs directly from our Web site. **See www.iFIT.com for more information.**

To use the manual mode of the console, follow the steps beginning on page 12. **To use a preset program**, see page 14. **To use a heart rate program**, see page 15. **To use an iFIT.com MP3, CD, or video program**, see page 19. **To use an iFIT.com program directly from our Web site**, see page 21.

HOW TO TURN ON THE POWER

- 1 Plug in the power cord (see page 10).
- 2 Locate the reset/off circuit breaker near the power cord. Make sure that the circuit breaker is in the reset position.

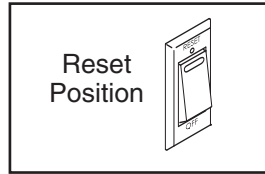

- 3 Stand on the foot rails of the treadmill. Find the clip attached to the key (see the drawing on page 11) and slide the clip onto the waistband of your clothes. Next, insert the key into the console. After a moment, the display will light. **Important: In an emergency situation, the key can be pulled from the console, causing the walking belt to slow to a stop. Test the clip by carefully taking a few steps backward; if the key is not pulled from the console, adjust the position of the clip.**

HOW TO USE THE MANUAL MODE

- 1 Insert the key into the console.
See HOW TO TURN ON THE POWER above.

- 2 Select the manual mode.

When the key is inserted, the manual mode will be selected. If a program has been selected, reselect the manual mode by pressing the Program Select button repeatedly until a track appears in the lower part of the display; make sure that the letters "iFIT" do not appear in the display.

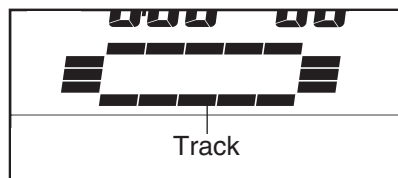

- 3 Start the walking belt.

To start the walking belt, press the Start button, the Speed + button, or one of the ten quick speed buttons.

If the Start button or the Speed + button is pressed, the walking belt will begin to move at 1 mph. As you exercise, change the speed of the

walking belt as desired by pressing the Speed + and – buttons. Each time a button is pressed, the speed setting will change by 0.1 mph; if a button is held down, the speed setting will change in increments of 0.5 mph. Note: After the buttons are pressed, it may take a moment for the walking belt to reach the selected speed setting.



If one of the quick speed buttons is pressed, the walking belt will gradually increase in speed until it reaches the selected speed setting.

To stop the walking belt, press the Stop button. The time will begin to flash in the display. To restart the walking belt, press the Start button, the Speed + button, or one of the quick speed buttons.

Note: The first time the treadmill is used, observe the alignment of the walking belt, and center the walking belt if necessary (see page 26).

- 4 Change the incline of the treadmill as desired.

To change the incline of the treadmill, press the Incline increase and decrease buttons. Each time a button is pressed, the incline will change by 0.5%. Note: After the buttons are pressed, it may take a moment for the treadmill to reach the selected incline setting.

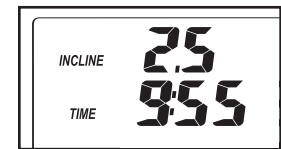

- 5 Follow your progress with the display.

When the manual mode or the iFIT.com mode is selected, the lower part of

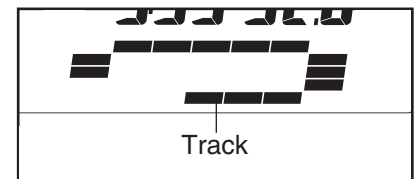

the display will show a 1/4-mile track. As you walk or run, the indicators around the track will appear in succession until the entire track appears. The track will then disappear and the indicators will again begin to appear in succession.

The left side of the display will show the incline level of the treadmill, the elapsed time, the approximate number of grams of carbs you have burned, and the distance you have walked or run. Note: Each time the incline changes, the display will show the incline setting for a few seconds. When a program is selected, the display will show the time remaining in the program instead of the elapsed time.

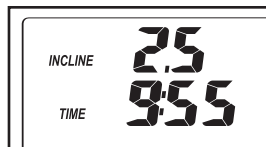

The right side of the display will show the speed of the walking belt, the approximate number of calories you have burned, and your pace (in minutes per mile). The display will also show your heart rate when you use the handgrip pulse sensor.

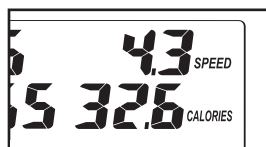

Note: The console can display speed and distance in either miles or kilometers. To determine which unit of measurement is selected, hold down the Stop button while inserting the key into the console. An “E” for English miles or an “M” for metric kilometers will appear in the right side of the display. Press the Speed + button to change the unit of measurement. When the desired unit of measurement is selected, remove the key. **Note: For simplicity, all instructions in this section refer to miles.**



To reset the display, press the Stop button, remove the key, and then reinsert the key.

6 Measure your heart rate if desired.

Note: Before using the handgrip pulse sensor, make sure that your hands are clean. If there are

sheets of clear plastic on the metal contacts on the handgrip pulse sensor, remove the plastic.

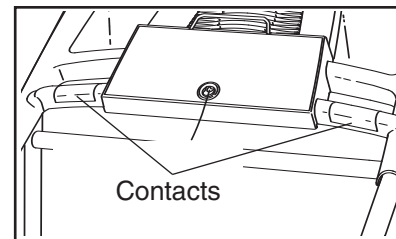

To measure your heart rate, **stand on the foot rails** and hold the metal contacts on the handgrip pulse sensor—**avoid moving your hands**. When your pulse is detected, the heart symbol in the right side of the display will appear, one or two dashes will appear, and then your heart rate will be shown. **For the most accurate heart rate reading, continue to hold the contacts for about 15 seconds.**

7 Turn on the fan if desired.

To turn on the fan, press the fan button (the fan button is located beside the Stop button). To turn on the fan at high speed, press the button a second time. To turn off the fan, press the button a third time. Note: A few minutes after the walking belt is stopped, the fan will automatically turn off.

8 When you are finished exercising, remove the key.

Step onto the foot rails, press the Stop button, and **adjust the incline of the treadmill to the lowest setting. The incline must be at the lowest setting when the treadmill is folded to the storage position or the treadmill will be damaged.** Next, remove the key from the console and put it in a secure place. **Note: If the display remains lit after the key is removed, the console is in the “demo” mode. See page 22 and turn off the demo mode.**

When you are finished using the treadmill, switch the reset/off circuit breaker to the off position and unplug the power cord.

HOW TO USE A PRESET PROGRAM

1 Insert the key fully into the console.

See HOW TO TURN ON THE POWER on page 12.

2 Select one of the four preset programs.

To select one of the four preset programs, press the Program Select button repeatedly. As

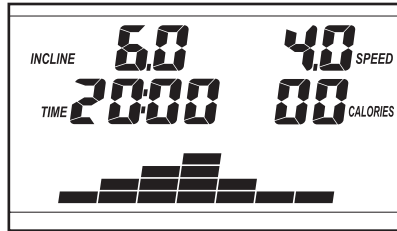

each preset program is selected, the maximum speed setting of the program and the maximum incline setting of the program will flash in the display for a few seconds. The display will also show how long the program will last. The matrix in the lower part of the display will show the first seven speed settings of the program.

3 Press the Start button or the Speed + button to start the program.

A moment after the button is pressed, the treadmill will automatically adjust to the first speed and incline settings for the program. Hold the handrails and begin walking.

Each program is divided into either 20 or 30 one-minute segments. One speed setting and one incline setting are programmed for each segment. Note: The same speed setting and/or incline setting may be programmed for two or more consecutive segments.

The speed setting for the first segment will be shown in the flashing Current

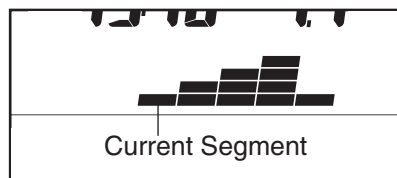

Segment column of the matrix in the lower part of the display. (The incline settings are not shown in the matrix.) The speed settings for the next four segments will be shown in the four columns to the right.

When only three seconds remain in the first segment of the program, both the Current Segment column and the column to the right will flash and a series of tones will sound. If the speed and/or incline of the treadmill is about to change, the speed setting and/or the incline setting will flash in the display to alert you.

When the first segment is completed, *all speed settings will move one column to the left*. The speed setting for the second segment will then be shown in the flashing Current Segment column and the treadmill will automatically adjust to the speed and incline settings for the second segment. Note: If all five of the indicators in the Current Segment column are lit, *the speed settings may move downward* so that only the highest indicators appear in the matrix.

The program will continue in this way until the speed setting for the last segment is shown in the Current Segment column and the last segment ends. The walking belt will then slow to a stop.

If the speed or incline setting for the current segment is too high or too low, you can manually override the setting by pressing the Speed or Incline buttons. Every few times a Speed button is pressed, an additional indicator will appear or disappear in the Current Segment column; if any of the columns to the right of the Current Segment column have the same number of lit indicators as the Current Segment column, an additional indicator may appear or disappear in those columns as well. **Important: When the current segment of the program ends, the treadmill will automatically adjust to the speed and incline settings for the next segment.**

To stop the program at any time, press the Stop button. The time will begin to flash in the display. To restart the program, press the Start button or the Speed + button. The walking belt will begin to move at 1 mph. When the next segment of the program begins, the treadmill will automatically adjust to the speed and incline settings for the next segment.

4 Follow your progress with the display.

See step 5 on page 12.

5 Measure your heart rate if desired.

See step 6 on page 13.

6 Turn on the fan if desired.

See step 7 on page 13.

7 When you are finished exercising, remove the key from the console.

When the program has ended, **make sure that the incline of the treadmill is at the lowest setting.** Next, remove the key from the console and put it in a safe place. **Note: If the display remains lit after the key is removed, the console is in the “demo” mode. See page 22 and turn off the demo mode.**

When you are finished using the treadmill, **switch the reset/off circuit breaker to the off position and unplug the power cord.**

HOW TO USE A HEART RATE PROGRAM

⚠ CAUTION: If you have heart problems, or if you are over 60 years of age and have been inactive, do not use the heart rate programs. If you are taking medication regularly, consult your physician to find whether the medication will affect your exercise heart rate.

1 Insert the key into the console.

See HOW TO TURN ON THE POWER on page 12.

2 Select a heart rate program.

To select a heart rate program, press the Program Select button repeatedly. The display will show

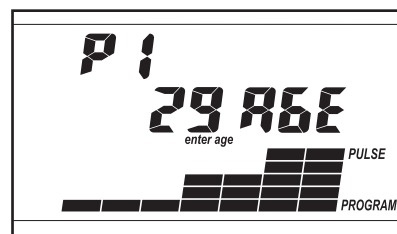

which program (“P1” or “P2”) is selected. When a heart rate program is selected, the matrix in the lower part of the display will show the first seven target heart rate settings of the program.

3 Enter your age.

When a heart rate program is selected, the word “AGE” will appear in the display and the current age setting will begin to flash. If you have already entered your age, simply press the Start button (the program will not start at this time). If you have not entered your age, press the Speed + and – buttons to enter your age, and then press the Start button.



4 Enter a maximum speed setting.

After you have entered your age, the letters “SPd” will appear in the display and the maximum speed setting of the program will begin to flash. If desired, press the Speed + and – buttons to change the maximum speed setting. Then, press the Start button (the program will not start at this time).



5 Enter a maximum target heart rate setting.

After you have entered a maximum speed setting, the letters “PLS” and the current maximum target heart rate setting of the program will appear in the display. Press the Heart Rate increase and decrease buttons to change the maximum target heart rate setting (see **EXERCISE INTENSITY** on page 27).



6 Hold the handgrip pulse sensor.

To use a heart rate program, you must hold the handgrip pulse sensor. It is not necessary to hold the pulse sensor continuously during the program; however, you should hold the pulse sensor frequently for the program to operate properly. **Each time you hold the pulse sensor, keep your hands on the metal contacts for at least 30 seconds.** Note: When you are not holding the pulse sensor, the letters “PLS” will appear in the display instead of your heart rate.

7 Press the Start button or the Speed + button to start the program.

A moment after the button is pressed, the treadmill will automatically adjust to the first speed and incline settings of the program. Hold the handrails and begin walking.

Each heart rate program is divided into either 20 or 30 one-minute segments. One target heart rate is programmed for each segment. Note: The same target heart rate may be programmed for two or more consecutive segments.

The target heart rate setting for the first segment will be shown in the flashing

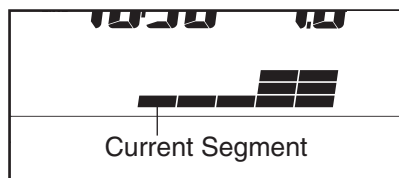

Current Segment column of the matrix. The target heart rate settings for the next four segments will be shown in the columns to the right.

When only three seconds remain in the first segment of the program, both the Current Segment column and the column to the right will flash and a series of tones will sound. In addition, the speed

setting and the incline setting will flash in the display to alert you. When the first segment ends, *all target heart rate settings will move one column to the left.* The target heart rate setting for the second segment will then be shown in the flashing Current Segment column.

During each segment, the console will compare your heart rate to the target heart rate. If your heart rate is too far below or above the target heart rate, the speed of the walking belt will automatically increase or decrease to bring your heart rate closer to the target heart rate. If the speed reaches the maximum speed setting of the program (see step 4 on page 15) and your heart rate is still too far below the target heart rate, the incline of the treadmill will also increase to bring your heart rate closer to the target heart rate.

The program will continue in this way until the target heart rate setting for the last segment is shown in the Current Segment column and the last segment ends. The walking belt will then slow to a stop.

If the speed or incline setting is too high or too low at any time during the program, you can adjust the setting with the Speed or Incline buttons. However, each time the console compares your heart rate to the target heart rate, the speed and/or incline of the treadmill may automatically change to bring your heart rate closer to the target heart rate.

To stop the program at any time, press the Stop button. The time will begin to flash in the display. To restart the program, press the Start button or the Speed + button. The walking belt will begin to move at 1 mph. When the console compares your heart rate to the target heart rate, the speed and/or incline of the treadmill may automatically change.

8 Follow your progress with the display.

See step 5 on page 12.

9 Turn on the fan if desired.

See step 7 on page 13.

10 When you are finished exercising, remove the key from the console.

See step 8 on page 13.

HOW TO CONNECT THE TREADMILL TO USE IFIT.COM PROGRAMS

To use iFIT.com MP3 or CD programs, the treadmill must be connected to your MP3 player, CD player, portable stereo, home stereo, or computer. See pages 17 and 18 for connecting instructions. To use iFIT.com programs directly from our Web site, the treadmill must be connected to your computer. See page 18 for connecting instructions. To use iFIT.com video programs, the treadmill must be connected to your VCR. See page 19 for connecting instructions.

HOW TO CONNECT YOUR MP3 PLAYER OR CD PLAYER

- A. Plug one end of the included 1/8" to 1/8" stereo audio cable into the input jack on the console. Plug the other end of the cable into a jack on your MP3 player or CD player. Plug your headphones into the headphone jack on the console.

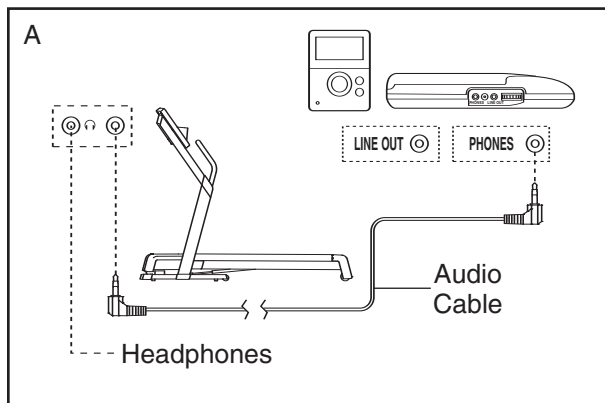

HOW TO CONNECT YOUR PORTABLE STEREO

Note: If your stereo has an RCA-type AUDIO OUT jack, see instruction A below. If your stereo has a 1/8" LINE OUT jack, see instruction B. If your stereo has only a PHONES jack, see instruction C.

- A. Plug one end of a long 1/8" to RCA stereo audio cable (available at electronics stores) into the input jack on the console. Plug the other end of the cable into the AUDIO OUT jack on your stereo.

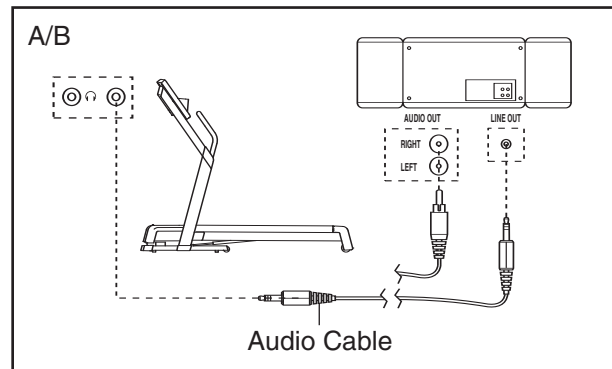

- B. See the drawing above. Plug one end of a long 1/8" to 1/8" stereo audio cable (available at electronics stores) into the input jack on the console. Plug the other end of the cable into the LINE OUT jack on your stereo. Note: While the cable is plugged into the LINE OUT jack, do not plug your headphones into the headphone jack on the console.
- C. Plug one end of a long 1/8" to 1/8" stereo audio cable (available at electronics stores) into the input jack on the console. Plug the other end of the cable into the PHONES jack on your stereo. Plug your headphones into the headphone jack on the console.

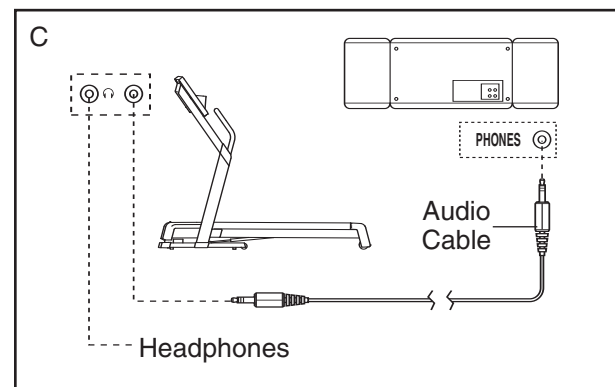

HOW TO CONNECT YOUR HOME STEREO

Note: If your stereo has an unused LINE OUT jack, see instruction A below. If the LINE OUT jack is being used, see instruction B.

- A. Plug one end of a long 1/8" to RCA stereo audio cable (available at electronics stores) into the input jack on the console. Plug the other end of the cable into the LINE OUT jack on your stereo. Note: While the cable is plugged into the LINE OUT jack, do not plug your headphones into the headphone jack on the console.

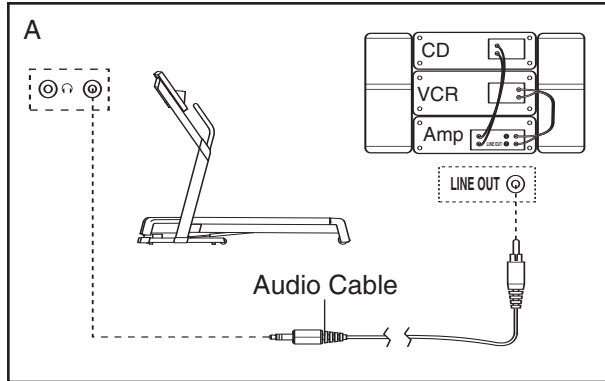

- B. Plug one end of a long 1/8" to RCA stereo audio cable (available at electronics stores) into the input jack on the console. Plug the other end of the cable into an RCA Y-adapter (available at electronics stores). Next, remove the wire that is currently plugged into the LINE OUT jack on your stereo and plug the wire into the unused side of the Y-adapter. Plug the Y-adapter into the LINE OUT jack on your stereo. Note: While the Y-adapter is plugged into the LINE OUT jack, do not plug your headphones into the headphone jack on the console.

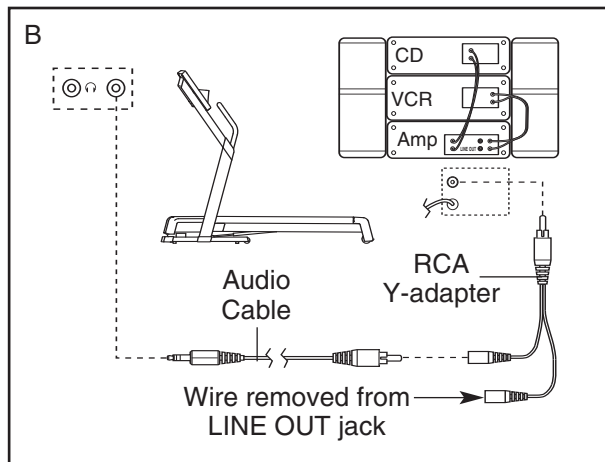

HOW TO CONNECT YOUR COMPUTER

- A. Plug one end of a long 1/8" to 1/8" stereo audio cable (available at electronics stores) into the input jack on the console. Plug the other end of the cable into the LINE OUT jack on your computer. Note: While the cable is plugged into the LINE OUT jack, do not plug your headphones into the headphone jack on the console.

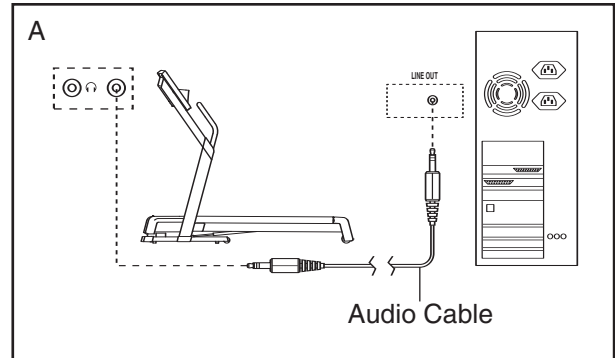

HOW TO CONNECT YOUR VCR

Note: If your VCR has an unused AUDIO OUT jack, see instruction A below. If the AUDIO OUT jack is being used, see instruction B. If you have a TV with a built-in VCR, see instruction B. If your VCR is connected to your home stereo, see **HOW TO CONNECT YOUR HOME STEREO** on page 18.

- A. Plug one end of a long 1/8" to RCA stereo audio cable (available at electronics stores) into the input jack on the console. Plug the other end of the cable into the AUDIO OUT jack on your VCR.

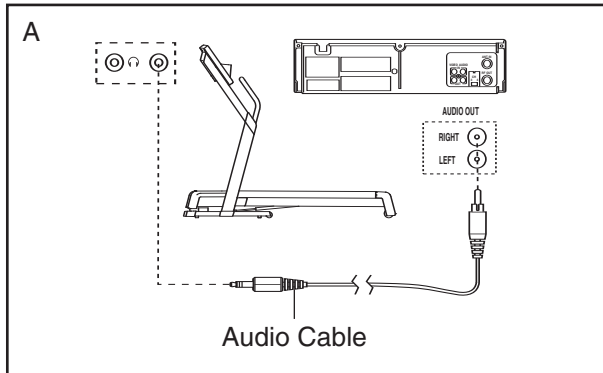

- B. Plug one end of a long 1/8" to RCA stereo audio cable (available at electronics stores) into the input jack on the console. Plug the other end of the cable into an RCA Y-adapter (available at electronics stores). Next, remove the wire that is currently plugged into the AUDIO OUT jack on your VCR and plug the wire into the unused side of the Y-adapter. Plug the Y-adapter into the AUDIO OUT jack on your VCR.

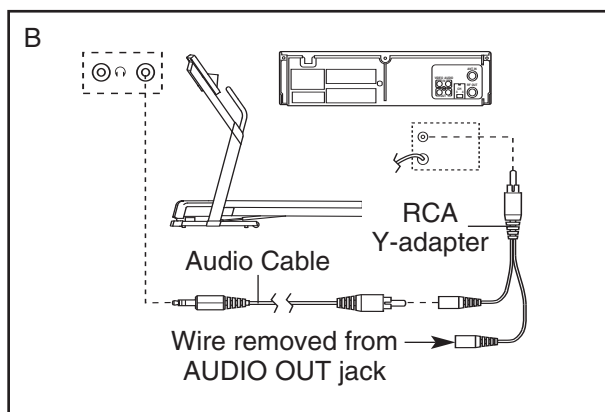

HOW TO USE AN iFIT.COM MP3, CD, OR VIDEO PROGRAM

To use an iFIT.com MP3, CD, or video program, the treadmill must be connected to your MP3 player, CD player, or VCR. See **HOW TO CONNECT THE TREADMILL TO USE iFIT.COM PROGRAMS** on pages 17 to 19. **To download iFIT.com MP3 programs, go to www.iFIT.com. To purchase iFIT.com CDs or videocassettes, call the toll-free telephone number on the front cover of this manual.**

Follow the steps below to use an iFIT.com MP3, CD, or video program.

1 Insert the key into the console.

See **HOW TO TURN ON THE POWER** on page 12.

2 Select the iFIT.com mode.

To select the iFIT.com mode, press the Program Select button repeatedly until the letters "iFIT" appear in the display.

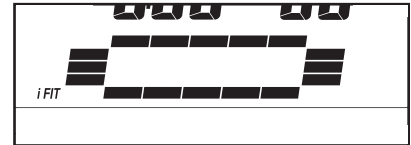

3 Press the Play button on your MP3 player, CD player, or VCR.

Note: If you are using an iFIT.com CD, insert the CD into your CD player; if you are using an iFIT.com videocassette, insert the videocassette into your VCR.

A moment after the Play button is pressed, your personal trainer will begin guiding you through your workout. Simply follow your personal trainer's instructions. Note: If the time is flashing in the display, press the Start button or the Speed + button on the console. The treadmill will not respond to an MP3, CD, or video program while the time is flashing in the display.

During the program, an electronic "chirping" sound will alert you when the speed and/or incline of the treadmill is about to change. **CAUTION: Always listen for the "chirp" and be prepared for speed and/or incline changes. In some instances, the speed and/or incline may change before your personal trainer describes the change.**

If the speed or incline settings are too high or too low, you can manually override the settings at any time by pressing the Speed or Incline buttons on the console. However, **when the next “chirp” is heard, the speed and/or incline will change to the next settings of the program.**

To stop the walking belt at any time, press the Stop button on the console. The time will begin to flash in the display. To restart the program, press the Start button or the Speed + button. After a moment, the walking belt will begin to move at 1.0 mph. **When the next “chirp” is heard, the speed and/or incline will change to the next settings of the program.**

When the program is completed, the walking belt will stop. Note: To use another MP3, CD, or video program, press the Stop button or remove the key and go to step 1 on page 19.

Note: If the speed and/or incline of the treadmill does not change when a “chirp” is heard:

- **Make sure that the letters “iFIT” appear in the display and that the time is not flashing in the display. If the time is flashing, press the Start button or the Speed + button on the console.**
- **Adjust the volume of your MP3 player, CD player, or VCR. If the volume is too high or too low, the console may not detect the program signals.**

- **Make sure that the audio cable is properly connected.**
- **If you are using a portable CD player and the CD skips, set the CD player on the floor or another flat surface instead of on the console.**
- **See the instructions at the bottom of page 27.**

4 Follow your progress with the display.

See step 5 on page 12.

5 Measure your heart rate if desired.

See step 6 on page 13.

6 Turn on the fan if desired.

See step 7 on page 13.

7 When you are finished exercising, remove the key from the console.

See step 8 on page 13.

CAUTION: Always remove iFIT.com CDs and videocassettes from your CD player and VCR and disconnect your MP3 player when you are not using them.

HOW TO USE AN iFIT.COM PROGRAM DIRECTLY FROM OUR WEB SITE

Our Web site at www.iFIT.com allows you to access basic programs, audio programs, and video programs directly from the internet. Additional options are soon to be available. See www.iFIT.com for details.

To use programs from our Web site, the treadmill must be connected to your home computer. See HOW TO CONNECT YOUR COMPUTER on page 18. In addition, you must have an internet connection and an internet service provider. A list of specific system requirements is found on our Web site.

Follow the steps below to use a program from our Web site.

1 Insert the key into the console.

See HOW TO TURN ON THE POWER on page 12.

2 Select the iFIT.com mode.

To select the iFIT.com mode, press the Program Select button repeatedly until the letters “iFIT” appear in the display.

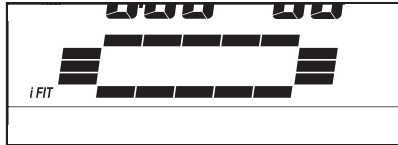

3 Go to your computer and start an internet connection.

4 Start your web browser, if necessary, and go to our Web site at www.iFIT.com.

5 Follow the desired links on our Web site to select a program.

Read and follow the on-line instructions for using a program.

6 Follow the on-line instructions to start the program.

When you start the program, an on-screen countdown will begin.

7 Return to the treadmill and stand on the foot rails. Find the clip attached to the key and slide the clip onto the waistband of your clothes.

When the on-screen countdown ends, the program will begin and the walking belt will begin to move. Hold the handrails, step onto the walking belt, and begin walking. During the program, an electronic “chirping” sound will alert you when the speed and/or incline of the treadmill is about to change. **CAUTION: Always listen for the “chirp” and be prepared for speed and/or incline changes.**

If the speed or incline settings are too high or too low, you can manually override the settings at any time by pressing the Speed or Incline buttons on the console. **However, when the next “chirp” is heard, the speed and/or incline will change to the next settings for the program.**

To stop the walking belt at any time, press the Stop button on the console. The time will begin to flash in the display. To restart the program, press the Start button or the Speed + button. After a moment, the walking belt will begin to move at 1.0 mph. **When the next “chirp” is heard, the speed and incline will change to the next settings of the program.**

When the program is completed, the walking belt will stop. Note: To use another program, press the Stop button and go to step 5.

Note: If the speed and/or incline of the treadmill does not change when a “chirp” is heard, make sure that the letters “iFIT” appear in the display and that the time is not flashing in the display. In addition, make sure that the audio cable is properly connected.

8 Follow your progress with the display.

See step 5 on page 12.

9 When you are finished exercising, remove the key from the console.

See step 8 on page 13.

THE INFORMATION MODE/DEMO MODE

The console features an information mode that keeps track of the total number of hours that the treadmill has been operated and the total number of miles that the walking belt has moved. The information mode also allows you to select miles or kilometers as the unit of measurement and to turn on and turn off the demo mode.

To select the information mode, hold down the Stop button while inserting the key into the console. When the information mode is selected, the following information will be shown in the display:

The left side of the display will show the total number of miles (or kilometers) that the walking belt has moved and the total number of hours that the treadmill has been used. An “E” for English miles or an “M” for metric kilometers will appear in the right side of the display. Press the Speed + button to change the unit of measurement.

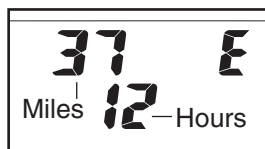

IMPORTANT: If a “d” appears in the right side of the display, the console is in the “demo” mode. This mode is intended to be used only when a treadmill is displayed in a store. When the console is in the demo mode, the power cord can be plugged in, the key can be removed from the console, and the indicators in the display will automatically appear in a preset sequence, although the buttons on the console will not operate. **If a “d” appears when the information mode is selected, press the Speed – button so “d” disappears.**

To exit the information mode, remove the key from the console.

HOW TO USE THE HAND WEIGHTS

To exercise your upper body as you walk on the treadmill, hold the 2-pound weights at your sides or press the weights above your head. To increase the intensity of your exercise, use the 3-pound weights. The hand weights can be stored in the weight rack.

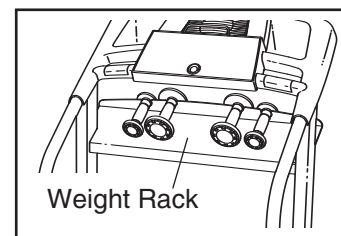

WARNING: Do not use the hand weights at speeds faster than walking speeds. Using weights and not holding the handrails may compromise your ability to maintain your balance. Exercises using weights should be attempted only by experienced users.

HOW TO FOLD AND MOVE THE TREADMILL

HOW TO FOLD THE TREADMILL FOR STORAGE

Before folding the treadmill, adjust the incline to the lowest position. If this is not done, the treadmill may be permanently damaged. Next, unplug the power cord. **CAUTION: You must be able to safely lift 45 pounds (20 kg) to raise, lower, or move the treadmill.**

1. Hold the treadmill with your hands in the locations shown by the arrow at the right. **To decrease the possibility of injury, bend your legs and keep your back straight. As you raise the frame, make sure to lift with your legs rather than your back.** Raise the frame about halfway to the vertical position.

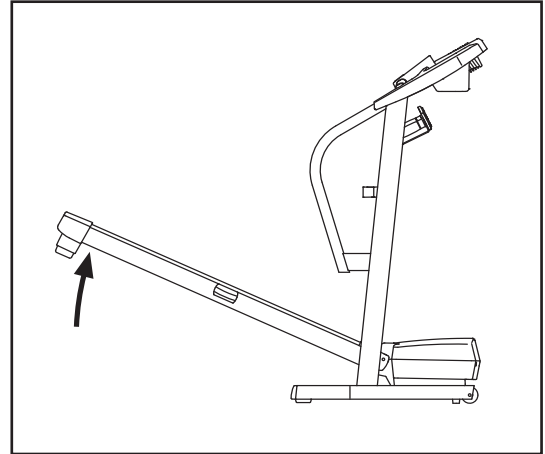

2. Move your right hand to the position shown and hold the treadmill firmly. Using your left thumb, press the storage latch to the left. Raise the frame until the storage latch closes over the catch. **Make sure that the storage latch is fully engaged over the catch.**

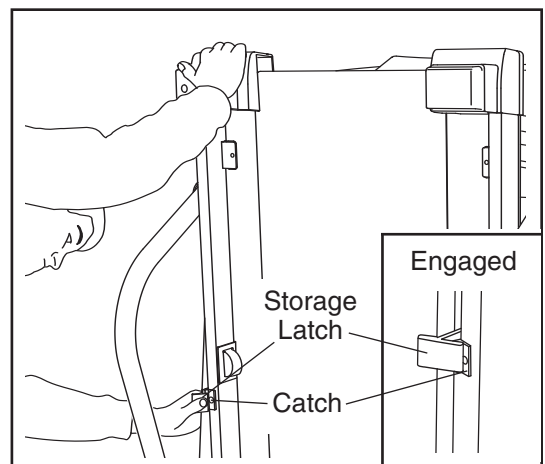

To protect the floor or carpet from damage, place a mat under the treadmill. Keep the treadmill out of direct sunlight. Do not leave the treadmill in the storage position in temperatures above 85° Fahrenheit.

HOW TO MOVE THE TREADMILL

Before moving the treadmill, convert the treadmill to the storage position as described above. **Make sure that the frame is securely held by the storage latch.**

1. Remove the weights from the weight rack.
2. Hold the upper ends of the handrails. Place a foot against one of the front wheels.
3. Tilt the treadmill back until it rolls freely on the wheels. Carefully move the treadmill to the desired location. **To reduce the risk of injury, use extreme caution while moving the treadmill. Do not move the treadmill over an uneven surface.**
4. Place a foot against one of the wheels, and carefully lower the treadmill until it is resting in the storage position.

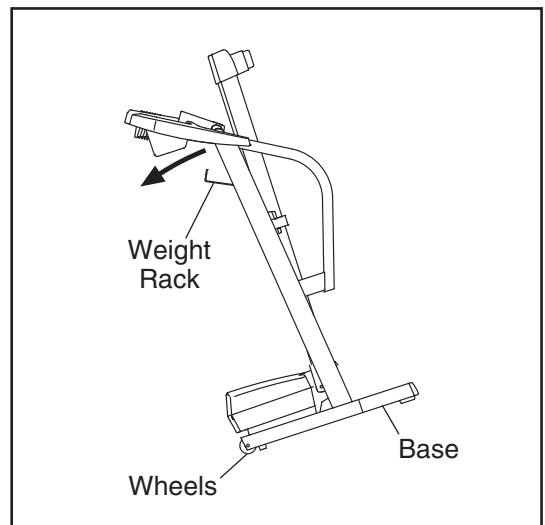

HOW TO LOWER THE TREADMILL FOR USE

1. Hold the upper end of the treadmill with your right hand. Press the storage latch to the left. Pivot the frame down until the frame and foot rail are past the storage latch.

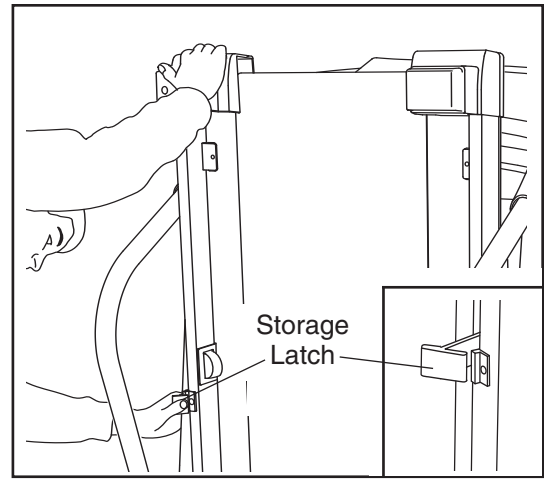

2. Hold the frame firmly with both hands, and lower it to the floor. **Do not drop the frame to the floor. To decrease the possibility of injury, bend your legs and keep your back straight.**

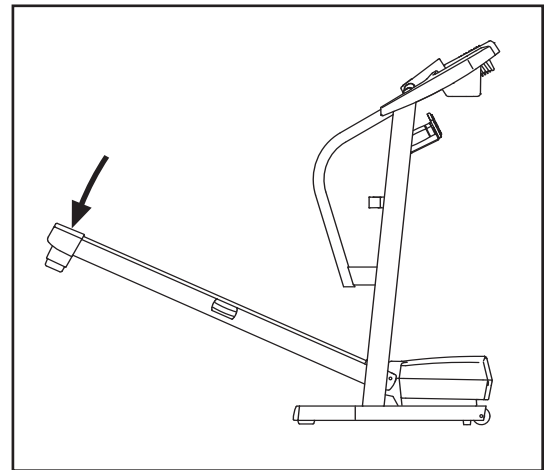

TROUBLESHOOTING

Most treadmill problems can be solved by following the steps below. Find the symptom that applies, and follow the steps listed. If further assistance is needed, please see the front cover of this manual.

PROBLEM: The power does not turn on

SOLUTION: a. Make sure that the power cord is plugged into a surge suppressor, and that the surge suppressor is plugged into a properly grounded outlet (see page 10). Use only a single-outlet surge suppressor that meets all of the specifications described on page 10. Important: The treadmill is not compatible with GFCI-equipped outlets.

b. After the power cord has been plugged in, make sure that the key is inserted into the console.

c. Check the reset/off circuit breaker located on the treadmill frame near the power cord. If the switch protrudes as shown, the circuit breaker has tripped. To reset the circuit breaker, wait for five minutes and then press the switch back in.

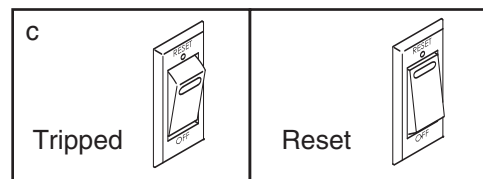

PROBLEM: The power turns off during use

SOLUTION: a. Check the circuit breaker located on the treadmill frame near the power cord (see the drawing above). If the circuit breaker has tripped, wait for five minutes and then press the switch back in.

b. Make sure that the power cord is plugged in. If the power cord is plugged in, unplug it, wait for five minutes, and then plug it back in.

c. Remove the key from the console. Reinsert the key into the console.

d. If the treadmill still will not run, please see the front cover of this manual.

PROBLEM: The displays of the console do not function properly

SOLUTION: a. Remove the key from the console and **UNPLUG THE POWER CORD**. With the help of another person, carefully tip the Upright (69) down as shown. Remove the two Screws (58) Note: A phillips screwdriver with at least a 5" shaft is required. If you can't access the Screws, lower the Upright to the floor, plug the power cord in, and adjust the incline of the treadmill until you are able to access the Screws.

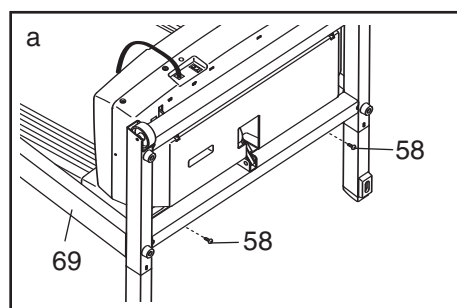

b. With the help of another person, carefully raise the Upright (69) as shown. Remove the Screws (58) from the Hood (1), and carefully pivot the Hood off.

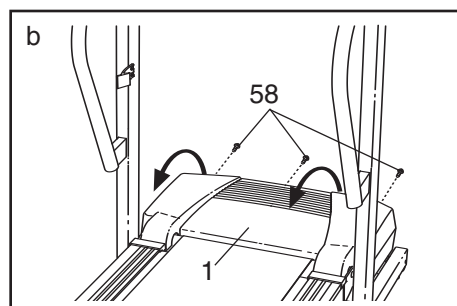

Locate the Reed Switch (10) and the Magnet (18) on the left side of the Pulley (17). Turn the Pulley until the Magnet is aligned with the Reed Switch. **Make sure that the gap between the Magnet and the Reed Switch is about 1/8"**. If necessary, loosen the Screw (49), move the Reed Switch slightly, and then retighten the Screw. Reattach the Hood, and run the treadmill for a few minutes to check for a correct speed reading.

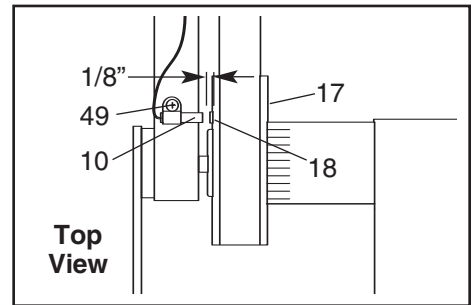

PROBLEM: The walking belt slows when walked on

SOLUTION: a. Use only a single-outlet surge suppressor that meets all of the specifications described on page 10.

b. If the walking belt is overtightened, treadmill performance may decrease and the walking belt may become damaged. Remove the key and **UNPLUG THE POWER CORD**. Using the hex key, turn both rear roller bolts counterclockwise, 1/4 of a turn. When the walking belt is properly tightened, you should be able to lift each edge of the walking belt 2 to 3 inches off the walking platform. Be careful to keep the walking belt centered. Then, plug in the power cord, insert the key, and run the treadmill for a few minutes. Repeat until the walking belt is properly tightened.

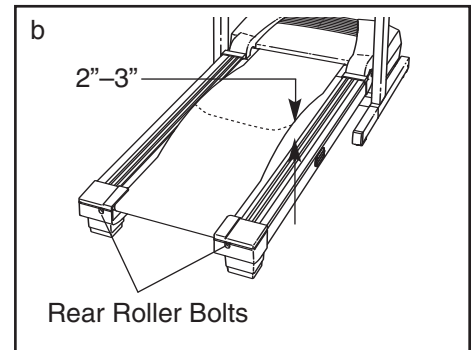

c. If the walking belt still slows when walked on, please see the front cover of this manual.

PROBLEM: The walking belt is off-center or slips when walked on

SOLUTION: a. If the walking belt is off-center, first remove the key and **UNPLUG THE POWER CORD**. **If the walking belt has shifted to the left**, use the hex key to turn the left rear roller bolt clockwise 1/2 of a turn; **if the walking belt has shifted to the right**, turn the left bolt counterclockwise 1/2 of a turn. Be careful not to overtighten the walking belt. Then, plug in the power cord, insert the key, and run the treadmill for a few minutes. Repeat until the walking belt is centered.

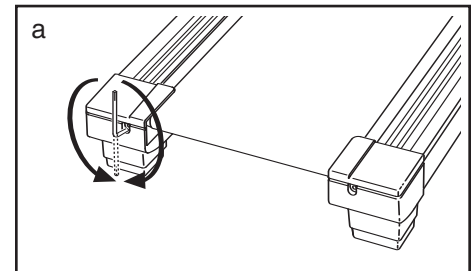

b. If the walking belt slips when walked on, first remove the key and **UNPLUG THE POWER CORD**. Using the hex key, turn both rear roller bolts clockwise, 1/4 of a turn. When the walking belt is correctly tightened, you should be able to lift each edge of the walking belt 2 to 3 inches off the walking platform. Be careful to keep the walking belt centered. Then, plug in the power cord, insert the key, and carefully walk on the treadmill for a few minutes. Repeat until the walking belt is properly tightened.

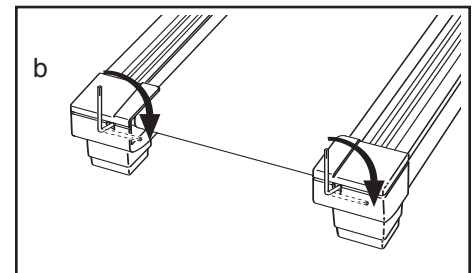

CONDITIONING GUIDELINES

⚠️ WARNING: Before beginning this or any exercise program, consult your physician. This is especially important for individuals over the age of 35 or individuals with pre-existing health problems.

The pulse sensor is not a medical device. Various factors, including your movement, may affect the accuracy of heart rate readings. The sensor is intended only as an exercise aid in determining heart rate trends in general.

The following guidelines will help you to plan your exercise program. For more detailed exercise information, obtain a reputable book or consult your physician.

EXERCISE INTENSITY

Whether your goal is to burn fat or to strengthen your cardiovascular system, the key to achieving the desired results is to exercise with the proper intensity. The proper intensity level can be found by using your heart rate as a guide. The chart below shows recommended heart rates for fat burning and aerobic exercise.

AEROBIC	165	155	145	140	130	125	115
MAX FAT BURN	145	138	130	125	118	110	103
FAT BURN	125	120	115	110	105	95	90
Age	20	30	40	50	60	70	80

To find the proper heart rate for you, first find your age near the bottom of the chart (ages are rounded off to the nearest ten years). Next, find the three numbers above your age. The three numbers define your “training zone.” The lower two numbers are recommended heart rates for fat burning; the higher number is the recommended heart rate for aerobic exercise.

Fat Burning

To burn fat effectively, you must exercise at a relatively low intensity level for a sustained period of time. During the first few minutes of exercise, your body uses easily accessible *carbohydrate calories* for energy. Only after the first few minutes does your body begin to use stored *fat calories* for energy. If your goal

is to burn fat, adjust the speed and incline of the treadmill until your heart rate is near the lowest number in your training zone.

For maximum fat burning, adjust the speed and incline of the treadmill until your heart rate is near the middle number in your training zone.

Aerobic Exercise

If your goal is to strengthen your cardiovascular system, your exercise must be “aerobic.” Aerobic exercise is activity that requires large amounts of oxygen for prolonged periods of time. This increases the demand on the heart to pump blood to the muscles, and on the lungs to oxygenate the blood. For aerobic exercise, adjust the speed and incline of the treadmill until your heart rate is near the highest number in your training zone.

WORKOUT GUIDELINES

Each workout should include the following three parts:

A Warm-up—Start each workout with 5 to 10 minutes of stretching and light exercise. A proper warm-up increases your body temperature, heart rate and circulation in preparation for exercise.

Training Zone Exercise—After warming up, increase the intensity of your exercise until your pulse is in your training zone for 20 to 60 minutes. (During the first few weeks of your exercise program, do not keep your pulse in your training zone for longer than 20 minutes.) Breathe regularly and deeply as you exercise—never hold your breath.

A Cool-down—Finish each workout with 5 to 10 minutes of stretching to cool down. This will increase the flexibility of your muscles and will help prevent post-exercise problems.

EXERCISE FREQUENCY

To maintain or improve your condition, complete three workouts each week, with at least one day of rest between workouts. After a few months, you may complete up to five workouts each week if desired. The key to success is to make exercise a regular and enjoyable part of your everyday life.

PART LIST—Model No. PFTL68505.1

R0307A

Key No.	Qty.	Description	Key No.	Qty.	Description	Key No.	Qty.	Description
1	1	Hood	39	6	1" Tek Screw	78	2	Cable Tie
2	17	3/4" Screw	40	1	Small Bolt	79	1	Power Cord Assembly
3	1	Motor Belt	41	1	iFIT.com Wire	80	2	Handrail U-nut
4	1	Motor Tension Bolt	42	1	Upright Wire	81	1	Belly Pan
5	5	3/8" Washer	43	1	Console	82	2	Belt Guide
6	3	Motor Star Washer	44	1	Latch Spacer	83	4	Belt Guide Screw
7	1	Flywheel	45	4	Isolator	84	1	Console Fan
8	1	Drive Motor	46	1	Book Holder	85	1	Rear Roller
9	2	2-pound Weight	47	1	Console Base	86	1	Frame
10	1	Reed Switch	48	8	1/2" Screw	87	1	Walking Platform
11	1	Latch Warning Decal	49	18	Hood Screw/ Endcap Screw	88	2	Lock Washer
12	2	Frame Spacer				89	2	Cable Tie Clamp
13	7	Frame Pivot Nut/Motor Nut	50	1	Key/Clip	90	1	5/32" Hex Key
14	2	Frame Pivot Bolt	51	1	Incline Motor	91	1	Sensor Clip
15	6	Walking Platform Screw	52	1	Incline Bracket	92	2	Rear Roller Adjustable Bolt
16	2	Foot Rail	53	1	Incline Motor Bolt, Lower	93	1	Right Rear Endcap
17	1	Front Roller/Pulley	54	3	Incline Pivot Bolt	94	1	Hex Key
18	1	Magnet	55	1	Motor Mount Bracket	95	1	Left Rear Endcap
19	1	Motor Pivot Bolt	56	1	Motor Controller Wire	96	1	Walking Belt
20	2	Motor Bracket Bolt	57	4	Base Pad	97	2	5/16" Star Washer
21	1	Right Foot Rail Endcap	58	9	3/4" Tek Screw	98	2	4" Bolt
22	3	Belly Pan Clip	59	1	Controller	99	1	Filter Wire
23	2	Fan Grill Screw	60	1	Lift Frame	100	1	Pulse Plate, Left
24	4	Isolator Screw	61	2	Extension Leg Pad	101	2	Isolator Cushion
25	4	Ground Screw	62	2	Warning Decal	102	2	3-pound Weight
26	2	Platform Nut	63	2	Extension Leg	103	2	Handrail Endcap
27	1	Fan Grill, Back	64	2	2" Bolt	104	1	Pulse Plate, Right
28	1	Motor Tension Nut	65	2	Base Endcap	105	1	Optic Disk
29	1	Storage Latch	66	2	Wheel	106	1	Small Nut
30	1	Latch Catch	67	4	U-nut	#	1	8" Black Wire, 2 Ring
31	2	Rear Endcap Pad	68	5	8" Cable Tie	#	1	6" Black Wire, 2 Ring
32	2	Wheel Nut	69	1	Upright	#	1	4" Black Wire, M/F
33	1	Static Decal	70	1	Grommet	#	1	8" Blue Wire, 2F
34	1	Left Grip Plate	71	1	Left Handrail	#	1	4" Blue Wire, 2F
35	1	Small Star Washer	72	1	Right Handrail	#	1	4" Blue Wire, M/F
36	1	Right Grip Plate	73	1	Choke	#	1	12" Green Wire, F/R
37	2	3" Bolt	74	1	Left Foot Rail Endcap	#	1	4" Red Wire, M/F
38	2	Washer	75	1	Silver Ground Screw	#	1	User's Manual
			76	1	Photo Switch			
			77	2	Wire Tie			

#These parts are not illustrated.

EXPLODED DRAWING—Model No. PFTL68505.1

R0307A

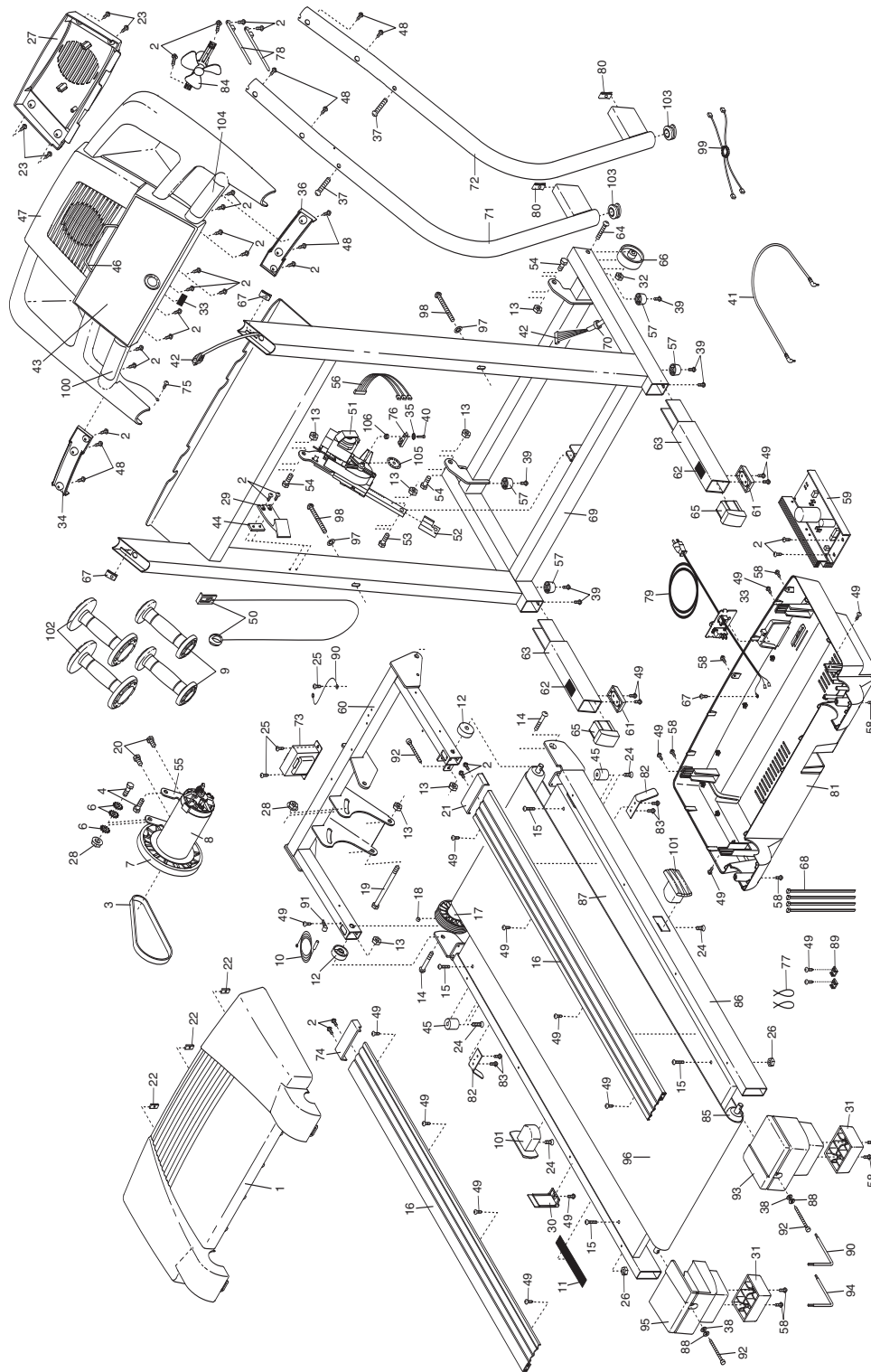

ORDERING REPLACEMENT PARTS

To order replacement parts, see the front cover of this manual. To help us assist you, please be prepared to give the following information:

- the MODEL NUMBER OF THE PRODUCT (PFTL68505.1)
- the NAME OF THE PRODUCT (PROFORM 400 GL+ treadmill)
- the SERIAL NUMBER OF THE PRODUCT (see the front cover of this manual)
- the KEY NUMBER AND DESCRIPTION OF THE PART(S) (see the EXPLODED DRAWING and PART LIST attached in the center of this manual)

LIMITED WARRANTY

ICON Health & Fitness, Inc. (ICON), warrants this product to be free from defects in workmanship and material, under normal use and service conditions. The drive motor is warranted for five (5) years after the date of purchase. Parts and labor are warranted for ninety (90) days after the date of purchase.

This warranty extends only to the original purchaser. ICON's obligation under this warranty is limited to replacing or repairing, at ICON's option, the product through one of its authorized service centers. All repairs for which warranty claims are made must be pre-authorized by ICON. If the product is shipped to a service center, freight charges to and from the service center will be the customer's responsibility. For in-home service, the customer will be responsible for a minimal trip charge. This warranty does not extend to any product or damage to a product caused by or attributable to freight damage, abuse, misuse, improper or abnormal usage or repairs not provided by an ICON authorized service center; products used for commercial or rental purposes; or products used as store display models. No other warranty beyond that specifically set forth above is authorized by ICON.

ICON is not responsible or liable for indirect, special or consequential damages arising out of or in connection with the use or performance of the product or damages with respect to any economic loss, loss of property, loss of revenues or profits, loss of enjoyment or use, costs of removal or installation or other consequential damages of whatsoever nature. Some states do not allow the exclusion or limitation of incidental or consequential damages. Accordingly, the above limitation may not apply to you.

The warranty extended hereunder is in lieu of any and all other warranties and any implied warranties of merchantability or fitness for a particular purpose is limited in its scope and duration to the terms set forth herein. Some states do not allow limitations on how long an implied warranty lasts. Accordingly, the above limitation may not apply to you.

This warranty gives you specific legal rights. You may also have other rights which vary from state to state.

ICON HEALTH & FITNESS, INC., 1500 S. 1000 W., LOGAN, UT 84321-9813