



Pro Stepper



Service Manual

e

Table of Contents

Table of Contents	0
Display Panel	1
Preventive Maintenance	2
Preventive Maintenance - Cont'd	3
Settings - Maintenance Mode	4
Settings - Maintenance Mode (cont.)	5
Diagnostics - Display Codes	6
Diagnostics - LED Test	7
Diagnostics - Keypad Test	8
Diagnostics - Heart Rate Test, Measurements	9
Trouble Shooting - How do I use the Stepper?	10
Trouble Shooting - FAQ	11
Trouble Shooting - Incorrect Model Setting	12
Trouble Shooting - Noise	13
Trouble Shooting - Noise- Clutch Pillow Blocks	14
Trouble Shooting - Noise - Springs	15
Trouble Shooting - Noise - Pedals	16
Part Installation Procedure - Shrouds	17
Parts Replacement - Shroud's	17
Part Installation Procedure - Shrouds	18
Part Adjsutment - Adjsuting Belt Tension	19
Part Installation Procedure - Load Control board Wiring	20
Part Installation Procedure - Alternator Wiring	21
Part Assemblies - Hardware Kit	22
Part Assemblies - Clutch Assembly	23
Part Assemblies - Display Assembly	24
Part Assemblies - Right Pedal Assembly	26
Part Assemblies - Left Pedal Assembly	25
Part Assemblies - Chain Link Assembly	27
Part Assemblies - Electrical Components	28
Part Assemblies - Frame Assembly Right	29
Part Assemblies - Frame Assembly Left	30
Part Assemblies - Frame Assembly Parts list...	31
Part Assemblies - Frame Assembly	32
Maintenance Log	33
Warranty	35



Display Panel



Pro Stepper Series 5100 display keypad



Preventive Maintenance

To keep your Star Trac Pro Stepper in top condition, Star Trac strongly recommends performing regular daily, weekly and monthly preventive maintenance routines outlined below.

Daily Maintenance

Remove excessive accumulations of dust, dirt and other substances by using a clean, soft cloth and a non-abrasive liquid cleaner, such as Formula 409™ or FANTASTIK™. Wipe down the exterior of the display panel, pedals, shrouds and heart rate grips.

Note: Do not spray directly on the display or heart rate grips.

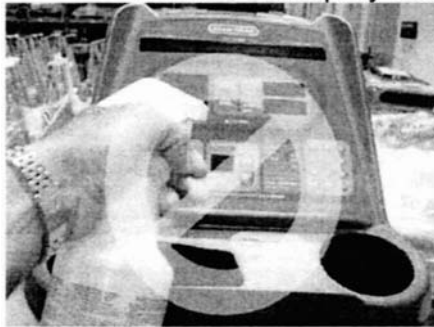

Spray on the cloth first then wipe the display.

Weekly Maintenance

Perform the following services each week:

- Vacuum the floor under and around the Pro Stepper. Move the unit to another spot, if necessary, to vacuum thoroughly.
- Inspect the screws (i.e. display panel mounting screws) for security, and retighten if necessary.
- Inspect the display panel keypads for wear.

Monthly Maintenance

Perform all the steps in weekly maintenance plus the following services each month, or as needed:

- Check that the pedals and shrouds are secure.
- Check for smooth and quiet operation of all moving parts.



Preventive Maintenance - Cont'd

Quarterly Maintenance

Perform all the steps in weekly and monthly maintenance plus the following services each month, or as needed:

Remove the return springs from the chains:

- Raise and lower the pedal arms and inspect for smoothness. Binding or excessive looseness might indicate a worn bushing.
- Rotate the clutch sprocket and inspect for smoothness. As you rotate the clutch towards the pedals it will turn the drive belt but as you turn the clutch towards the drive belt it will spin freely and will not turn the drive belt.
- Inspect the chain pulleys by spinning them.
 - a. If they spin freely they are ok
 - b. If they bind check for areas that bind and adjust or replace as needed.
- Inspect the chains and springs for wear.
 - a. Frozen links will require a chain replacement.
- Lubricate the chain with white lithium grease.
- Rotate the clutch sprockets 180 degrees from the original position and reassemble the springs and chain back onto the sprockets.





Pro Stepper Service Manual

Settings - Maintenance Mode

The Maintenance Mode allows you to query and modify the basic settings of the Star Trac Pro Stepper.

Engaging Maintenance Mode

Press and hold the ,  and  keys together. A beep will sound and the "MAINTENANCE MODE" will display momentarily in the information window. Release all keys. "SERIAL NO XXXXX" will display in the information window.

Modifying the Maintenance Mode

The following keys are used to modify Maintenance Settings:

Upper and Lower Data Information Window SCROLL keys: Display the next  and previous settings.

Increase and Decrease Level Keys: Adjust the value of the displayed setting up and down respectively, in increments of 1 unit.



OK Key: Updates (saves) the value of the display setting in the Flash memory, and exits Maintenance Mode.



Maintenance Mode Settings

The items that you may display and change:
Default values set in 0

Serial Number	Pro Stepper serial number (0)
Date	Manufactures date for the Pro Stepper (01/05)
Display Vers 1	Display software version (N/A)
Display Vers 2	Display software version (N/A)
LCa Vers	LCB software version (N/A)
Units	English = units of pounds, miles, feet inches; (English) Metric = units of kilograms, kilometers, centimeters
Time	Maximum time in minutes allowed for program, excluding warm-up and cool-down (20)
Weight	Default (to user), typical weight in lb (UNITS=English) or kg (UNITS = Metric) (350 lbs, 159 KG)



Pro Stepper Service Manual

Settings - Maintenance Mode (cont.)

Language	Language is English, Dutch, French, German, Spanish, Swedish, Italian or Katakana (English)
Model	PB-UB =Pro Bike Upright, PB-RB =Pro Bike Recumbent, Pro CT = Pro CrossTrainer, Elite CT =Elite CrossTrainer, Stepper =Pro Stepper
LCB Type	LCB hardware version Ver3
CSAFE	Turns on/off CSAFE functionality (Off)
Auto Status	Turns on/off the unsolicited status of the CSAFE feature (Off)
Wall Power	Turns the wall power setting on/off (Off)
IRDA	Turns on/off infrared port functionality (Off)
OPER Hours	Total operating hours (0)
Quick Start	Number of times the Quick Start program was run since last reset (0)
Manual	Number of times the Manual program was run since last reset (0)
Fat Burner	Number of times the Fat Burner program was run since the last reset (0)
IHR Pro	Number of times the Interval Heart Rate Control program was run since the last reset (0)
CHR Pro	Number of times the Constant Heart Rate Control program was run since last reset (0)
Fit Test	Number of times the Fitness Test program was run since last reset (0)
GLT Sculpt	Number of times the Glute Sculptor program was run since last reset (0)
Thigh TNR	Number of times the Thigh Toner program was run since last reset (0)
Famous Step	Number of times the Famous Step program was run since last reset (0)
Comm Lost	Number of times a Comm Lost condition has occurred. See Display Codes
Key Down	Number of times a Key Down condition has occurred. See Display Codes
LED Test	Access to integral LED test function
Keypad Test	Access to integral keypad test function
Heart Rate Test	Access to integral heart rate system test function
Measurements	Access to integral measurements function



Diagnostics - Display Codes

Display Codes

Star Trac Pro Steppers perform a self-test at the beginning of every workout. If a problem is detected, a message displays before or after the workout, depending on the nature of the problem.

Key Down - One or more keys on the display panel are stuck in the "on" position for at least 10 seconds. This can occur if a user presses keys before the system is turned on.

Comm Lost - Communication between the Load Control Board (LCB) and the display are lost. This can occur if the display cable is not connected securely at install.



Diagnostics - LED Test

LED Test

The LED Test can be used to verify that all LED (lights) are functioning on the display assembly.

To engage the LED Test

Enter the Maintenance Mode (see Settings - Maintenance Mode).

Press  until LED Test is displayed in the information window.

Press  to enter the LED Test. All lights on the display should be on.

Check for any burned out lights.

To exit the LED Test, press .

If any of the LED's do not illuminate, they may not be functioning and the display electronics should be replaced.





Diagnostics - Keypad Test

Keypad Test

The Keypad Test can be used to verify that all keys are functioning on the display assembly.

To engage the Keypad Test

Enter the Maintenance Mode (see Settings - Maintenance Mode).

Press  until Keypad Test is displayed in the information window.

Press  to enter the Keypad Test.

Press each key on the display. Each time you press a key, the information window will display which key has been pressed.

To exit the keypad test, press .

If any of the keys do not respond, they may not be functioning and the display keypad must be replaced.





Diagnostics - Heart Rate Test, Measurements

Heart Rate Test

Heart Rate can be checked using the Heart Rate Test.

To verify heart rate operation:

Enter the Maintenance Mode (see Settings - Maintenance Mode).

Press  until Heart Rate Test is displayed in the information window.

Press  to enter Heart Rate Test.

The display will read TELEMETRY.

If checking contact heart rate it will read "CONTACT" and the heart rate number.

If checking Polar, the display will read "TELEMETRY" and the heart rate number.

5. To exit the heart rate test, press 

Measurements Mode

Measurements can be done to verify the voltage of the battery.

To verify the battery voltage:

Enter the Maintenance Mode (see Settings - Maintenance Mode).

Press  until Measurements is displayed in the information window.

Press  to enter Measurements.

The display will read "BATT VLT =" and the voltage of the battery.

To exit the measurements, press 



Pro Stepper Service Manual

Trouble Shooting - How do I use the Stepper?

Q. Why does the stepper not have any resistance when I increase the level?

A. When pressing the up ▲ or down ▼ key you are actually changing the workout level of the user.

Press the increase (UP) ▲ level key the pedals will fall faster and there is less resistance so you have to work harder to keep up with it.

Press the down level (DOWN) ▼ it makes the pedals move slower so it is easier to keep up with it.



Do not let the pedals touch the floor. Step fast enough to keep the pedals in their middle range, with step heights from 2 to 16 inches. If the pedals sink to the floor, step faster or decrease your work level by pressing the level down key ▼.



Trouble Shooting - FAQ

Symptom	Possible Problem	Solution	Page #
Squeaking noise	Loose bearing	Check all bearings	14
Clicking Noise	Possible spacer missing	Examine clutch assembly	23
Popping noise	Frozen link on chain	Examine chain links	27
Pedals Slip	Possible clutch failure	Perform clutch and belt test	19
Loose Pedals	Bushing wear	Inspect bushings on pedal arms and pedals	16
No Power	Low battery	Check battery and connections	29
No resistance (Pedals fall) at level1 to 5	Possible low battery or RPM sensor out of alignment	Check battery voltage and rpm sensor alignment	28
Too much resistance (Pedals won't move) at level 10 to 15	Possible model error or LCB failure	Check model in Maintenance mode. Swap LCB	12
Turns on but does not give speed	RPM sensor	Check RPM sensor LED on LCB (Load control board)	18
Start Pedaling	Wrong Model Selected	Change Model to Pro Stepper	12
Start Striding	Wrong Model Selected	Change Model to Pro Stepper	12
I forgot where the wires go on the alternator	Wires may be in the wrong position	Refer to the wiring photo	21
I'm replacing the LCB but am not sure where the connectors plug in.	The connectors are all different shapes so it is not possible to plug them in the wrong place	Refer to the LCB wiring diagram	20



Trouble Shooting - Incorrect Model Setting

The display electronics on the Pro Stepper can be configured to operate with many different models of Star Trac products. For them to operate properly, the correct model must be set in the Maintenance mode.

If the correct model is not set, the following may happen:



When the unit is powered up, the display will read "Pro Bike" (or Pro CrossTrainer or Elite CrossTrainer) in the level profile window.

The display will read "Start Pedaling" or "Start Striding" instead of "Start Stepping".

Also, some programs will not work when the keys are pressed. i.e. When pressing the Hr Training Program Key, the Total Body program or Warm Up program will start.

If you experience any of these symptoms, engage the Maintenance mode to correct the Model setting.

Engaging Maintenance Mode

Press and hold the ,  and  keys together. A beep will sound and the "MAINTENANCE MODE" will display momentarily in the information window. Release all keys. "SERIAL NO XXXXX" will display in the information window.

Press the  until the display reads "Model".

Press the  until the correct setting shows.
Stepper = Pro Stepper

Press  to save the setting and exit the maintenance mode. Test for functionality.



Trouble Shooting - Noise

Noise is one of the hardest things to diagnose because it may only make the noise under certain conditions. To find the part that is making the noise will require some patience and trial and error. It may also require the help of another person to slowly and safely move the part while another person listens.

NOTE: Always use safe work practices and do not allow clothing, hair or fingers to get caught in moving parts.

Try these methods when trying to locate the noise:

- Move the product to a quiet location to help in diagnosing the noise when possible.
- Loosen or tighten screws to make the noise louder or eliminate the noise. Often a noise will change its pitch when you do this and that may point you towards the correct part.
- Gently and carefully when possible spray a little lube on the bearing or shaft to see if the noise will get quieter. This is very successful when a shaft is spinning within a bearing and making a squealing noise.
- Remove part of the moving assembly to help isolate the noise.
- Try swapping parts, such as with the pedal springs, one spring may make a noise and not the other. Swap the springs to determine if the spring is at fault or the pulley, etc.
- Check for worn or damaged parts such as a worn spot on a plastic pulley.
- Look for metal shavings which might indicate a worn bearing or a set screw that is not tight.

The following pages discuss some areas that have moving parts and could be the source of noise.

Proper cleaning and lubrication as suggested in maintenance can prevent noises.

Trouble Shooting - Noise- Clutch Pillow Blocks

The noise that you might hear as a result of the pillow block bearings being loose is a slight click or ticking sound.

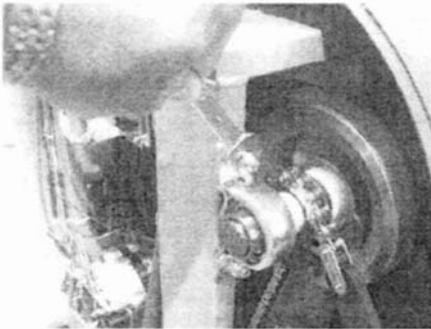

- Use two 9/16 wrenches (or socket and wrench) to verify that all 4 bolts and nuts on the upper and lower pillow block assemblies are tight.
- Loosen the nuts and then ride it a little to let it settle, then tighten the nuts to determine if the noise is from the alignment of the shaft to the bearing.

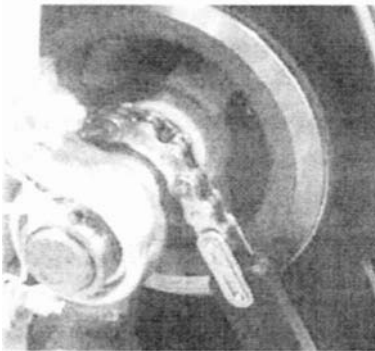

- Loosen the set screws and rotate the shaft so the set screw is in the detent in the shaft. Tighten the set screw in the detent first then the other set screw and repeat the procedure on the other side.

Trouble Shooting - Noise - Springs

Noise from the springs may make a pinging or a rubbing sound. Check the spring to make sure it is not twisted and the pulley is turning as the spring rolls over it.

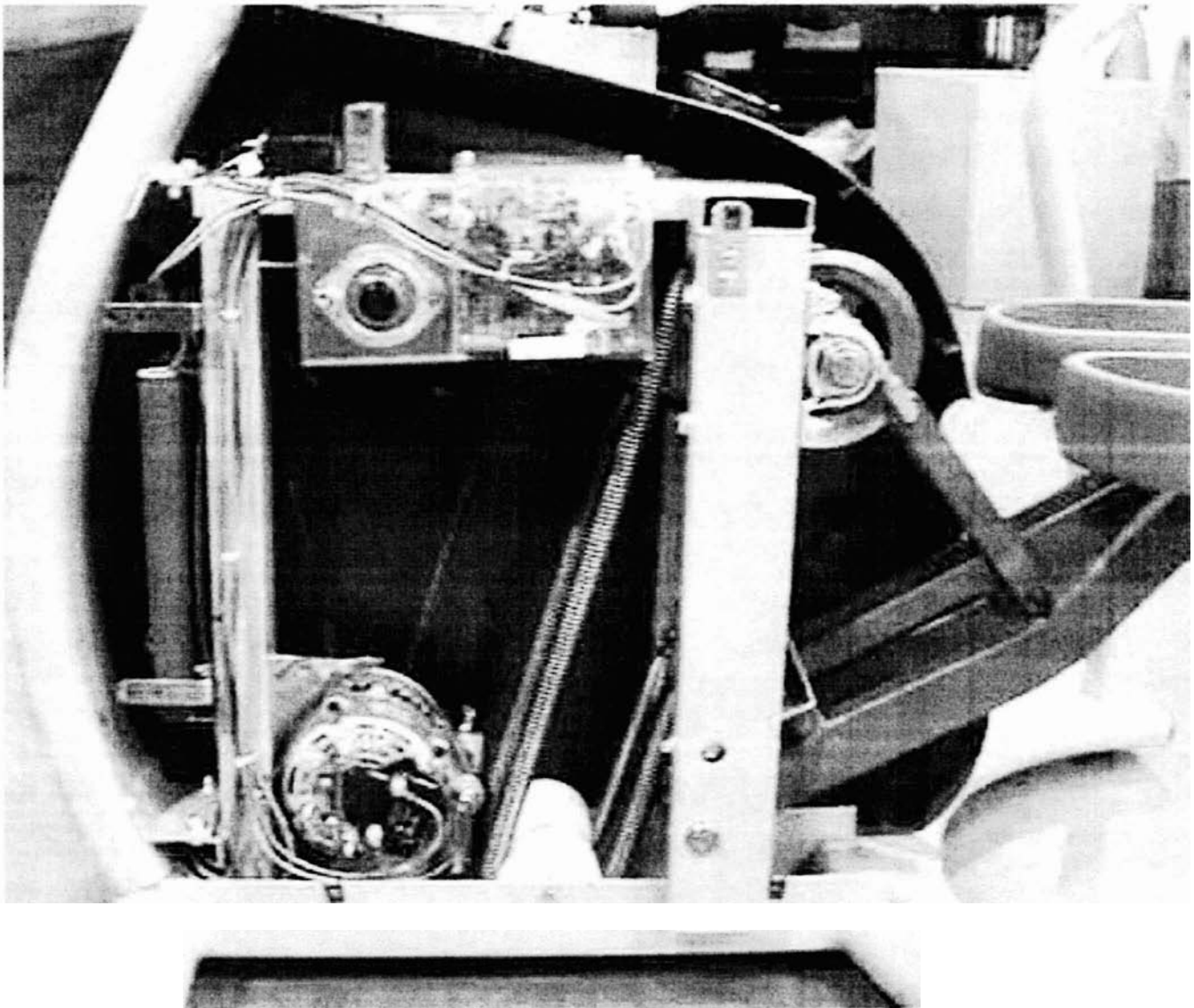



Trouble Shooting - Noise - Pedals

- Check all hardware under the pedals for looseness.
- Check clips and springs to make sure they are aligned properly so they do not come off.

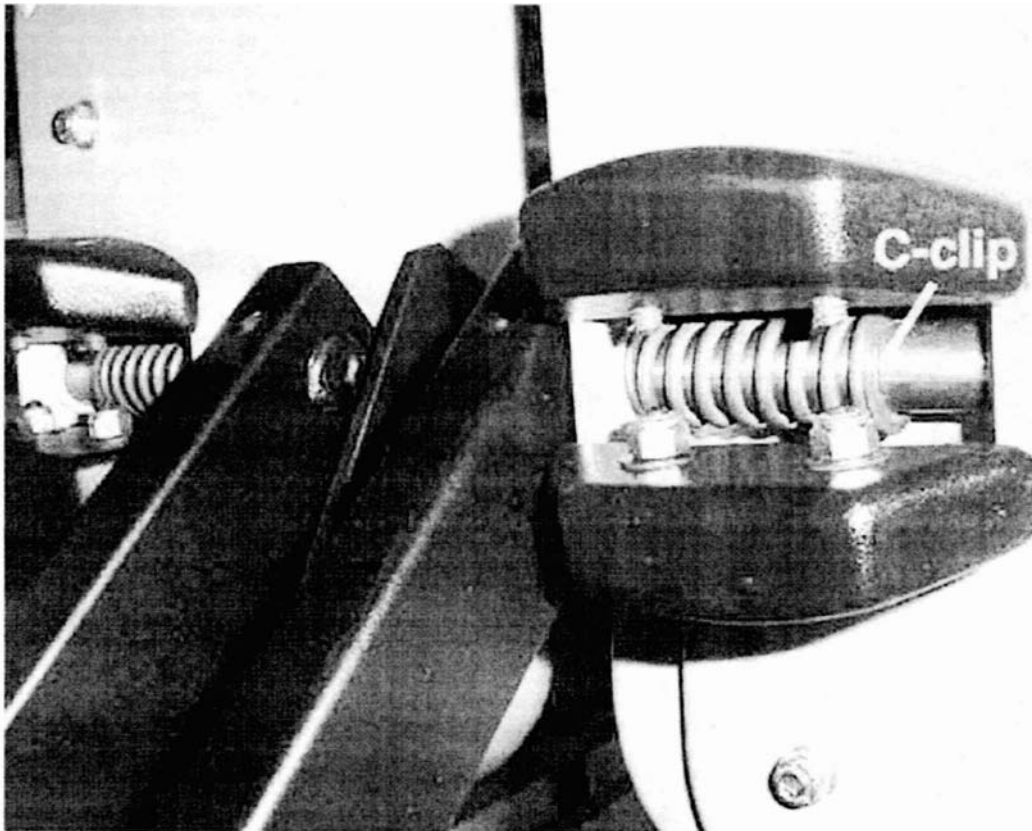

Parts Replacement – Shroud's

Parts Needed:

Shroud Left (711-3165-01)

Shroud Right (711-3165-02)

**Tools Needed:**

Phillips Head Screwdriver

Procedure:

Remove the Shroud by unscrewing the 6 screws on each side of the shroud and lift the shroud off the frame. Be careful not to pull on any of the cables as you remove the shroud.

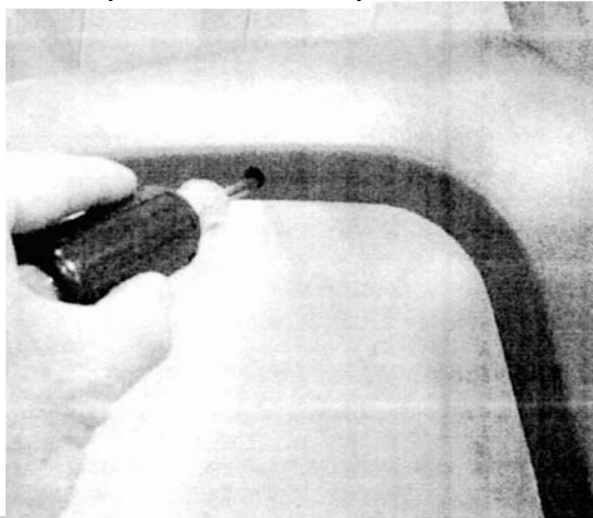

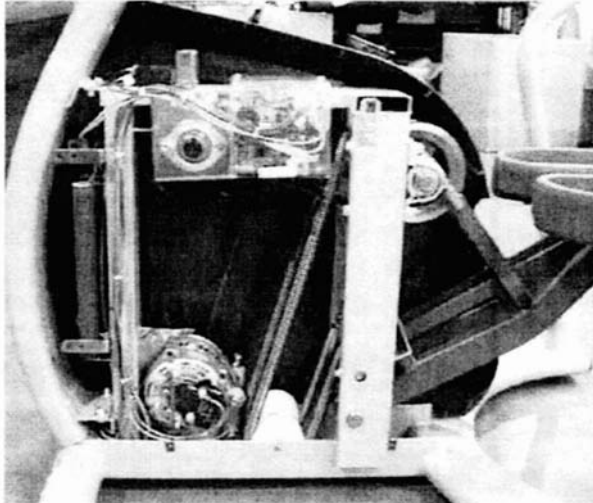
Part Installation Procedure - Shrouds

Open the left side for testing the alternator and the cables.

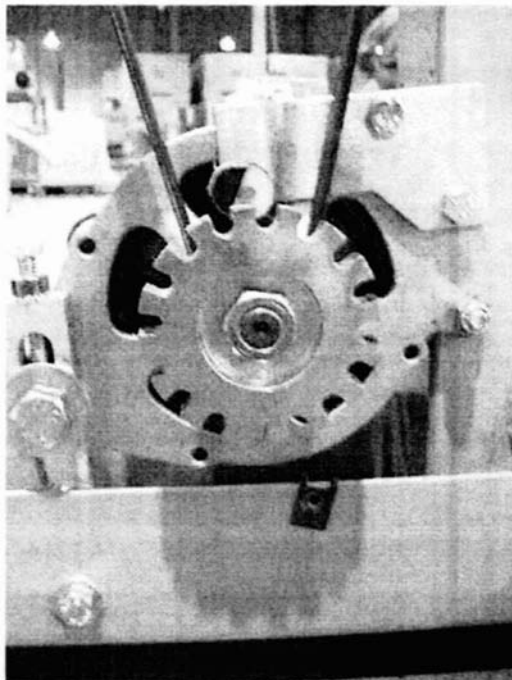

The RPM sensor and alternator adjustments are accessible from the right side.

The gap on the RPM sensor should be approx. 1 credit card.

Part Adjustment - Adjusting Belt Tension

To adjust the tension of the main drive belt perform the following check.



- If the drive belt is slipping on the adjustable bracket assembly or the main pulley in-between the clutch sprockets, the belt will have to be tightened.
- Using a 9/16" inch open end wrench, loosen the large nuts holding the adjustable bracket on the frame of the stepper.

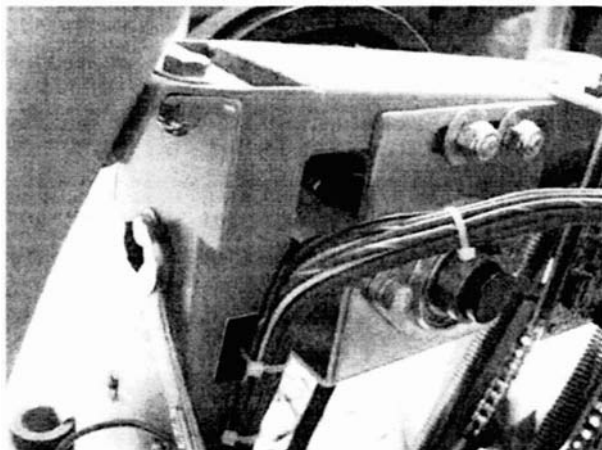

- Using a 7/16" open end wrench or socket wrench, turn the bolt in the front of the frame.
- To tighten the belt, turn the bolt clockwise this will pull the adjustable bracket forward. This will tighten the belt.
- To loosen the belt, turn the bolt counter clockwise. This will push the adjustable bracket closer to the pedals. This will loosen the belt.



Part Installation Procedure - Load Control board Wiring

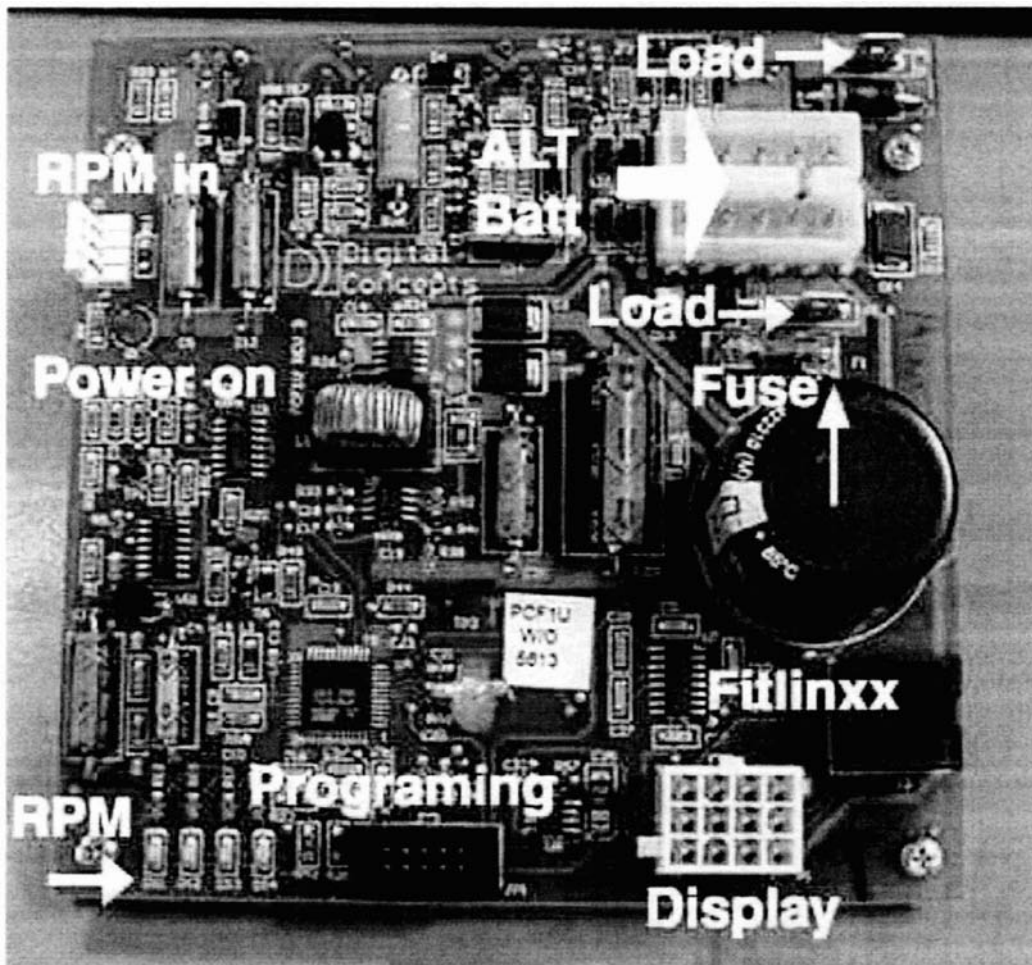

Lea Wiring

- The LCB is protected from sweat and moisture by a clear plastic cover, remove this cover while accessing the LCB.
- All the connectors are keyed and will only fit properly in one direction.
- Make sure the connector is fully seated and locked.
- Run wires away from moving parts and tie wrap as needed.
- Not the RPM led, this will be lit when the rpm sensor is detecting the rotation of the alt flywheel.

Part Installation Procedure - Alternator Wiring

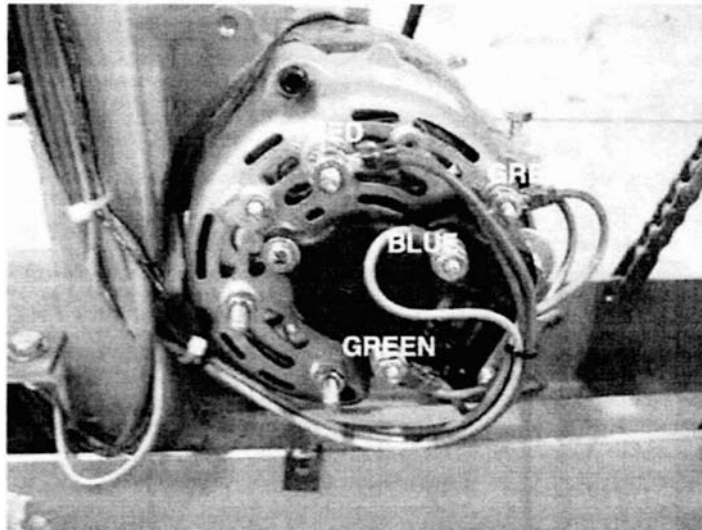

Alternator Wiring

The alternator is wired as shown in the above photo. Make sure contacts are clean and secure.

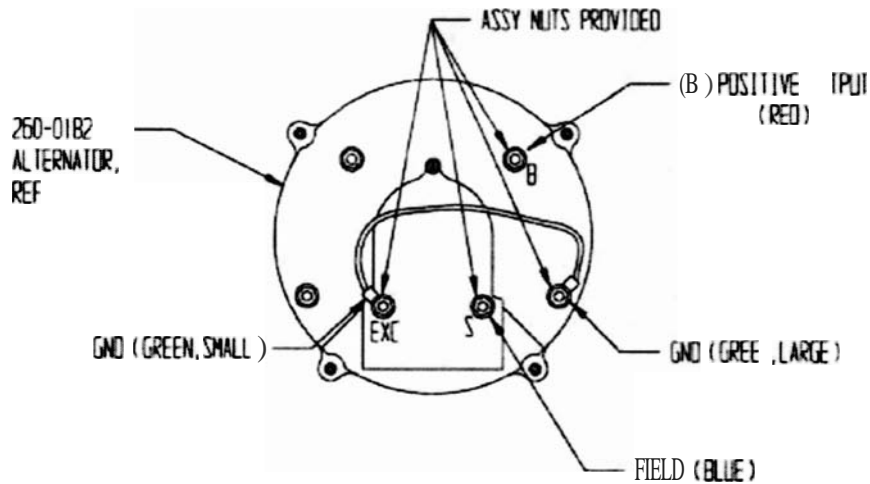

**Alternator Wiring Diagram
Pro Stepper**



Part Assemblies - Hardware Kit

711-3182 Kit, Hardware 5100 Stepper

KEW M6X16 (NECK JOINT)

ITEM NO.	PART NUMBER	DESCRIPTION
1	110-0506	SCREW, 1/4-28x3/8, BHC, HK, SS, BO
2	110-3172	SCREW, ISO10642, M6x16
3	290-0040	HEX L-KEY, 5/32 "

Part Assemblies - Clutch Assembly

Kit Part Number 800-3114 Drive Shaft Assembly

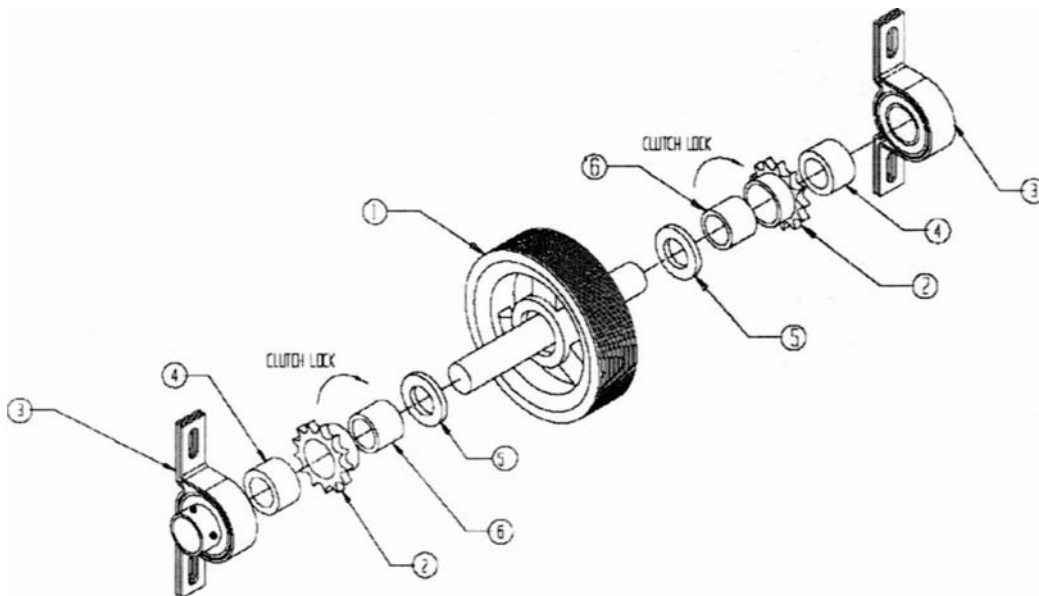

ITEM	P/N	DESCRIPTION	QTY
1	71 J-0105	PIIIEY, MAIN DRIVE WELDED	1
2	130-1537	SPROCKET 13 TEETH	2
3	130-0401	PILLOW BLOCK \'	2
4	020-o019	SPACER MAIN DRIVE .91' LG	2
5	020-o018	SPACER MAIN DRIVE .20' THK	2
6	020-1760	CLUTCH ROLLER 1"	2

Part Assemblies - Display Assembly

Drawing # 711-3151

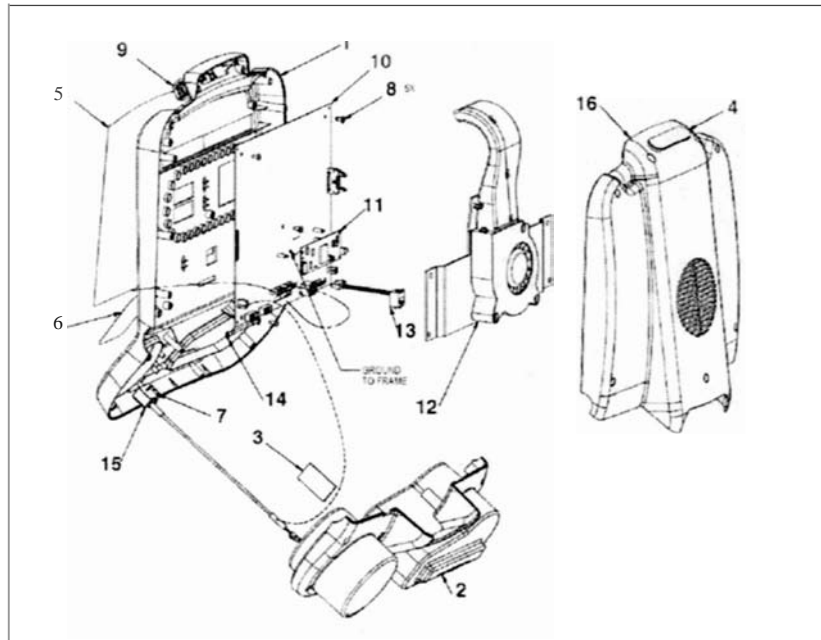

1 : \1	PART NO	DESCRIPTION	QTY
	020-6413	DISPLAY FRONT UB/RB PRO	1
2	020-6416	DISPLAY BOTTOM PRO BIKE	1
3	020-6460	WINDOW R READER UB/RB	1
4	050-1687	LABEL LOGO STAR TRAC PRO BIKE	1
	050-1926	KEYPAD PRO STEPPER, ENGL	1
	050-1932	LABEL INFO CENTER, UNIVERSAL	1
	110-3163	SCREW, M3x0.5x8L PHT PH,CS,ZI	1
8	110-3252	SCREW, M4x0.7x10L PHT PH,CS,BD	5
	718-1107	ASSY AIR VENT UB/RB	1
10	718-1108	ASSY DISPLAY BOARD POPULATED UB/RB PRO	1
11	718-1129	POB HR CONTACT UB/RB PRO	1
12	720-5068	ASSY FAN WBRACKET PRO BIKE	1
13	721-0033	ASSY, CONN., FITLINX/CARDIO	1
14	721-1065	ASSY HARNESS GROUND, EL6200	1
15	715-3518	ASSY CABLE POLA- RECEIVER, PRO/IS	1
16	020-6416	DISPLAY BACK, PRO BIKE	1

Part Assemblies - Left Pedal Assembly

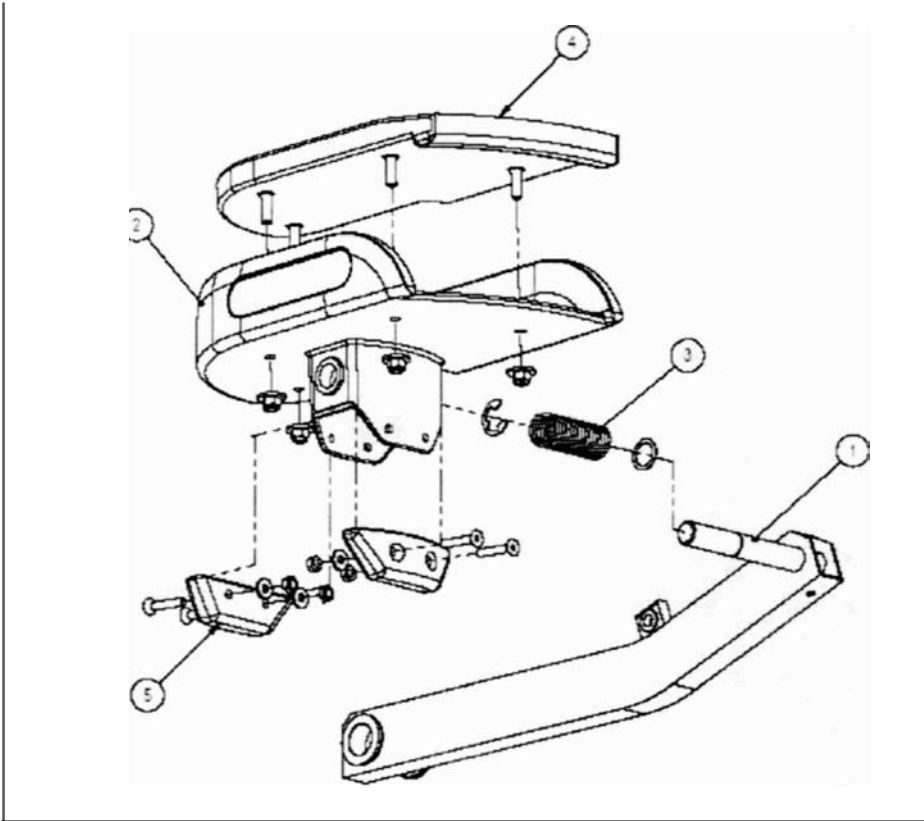

Drawing

711-1045-01 Pedal assy Left

	PART NUMBER	DESCRIPTION	QTY
	711-3173-01	ASSY, PEDAL ARM, W/BUSHING, LEFT	1
	711-3174-01	ASSY, PEDAL W/BUSHING, LEFT	1
	711-3175	KIT, SPRING FOOT PIVOT	1
	711-3176-01	KIT PEDAL PAD LEFT	1
	711-3177	KIT, PEDAL STOPS, 5100 STEPPER	1

Part Assemblies - Right Pedal Assembly

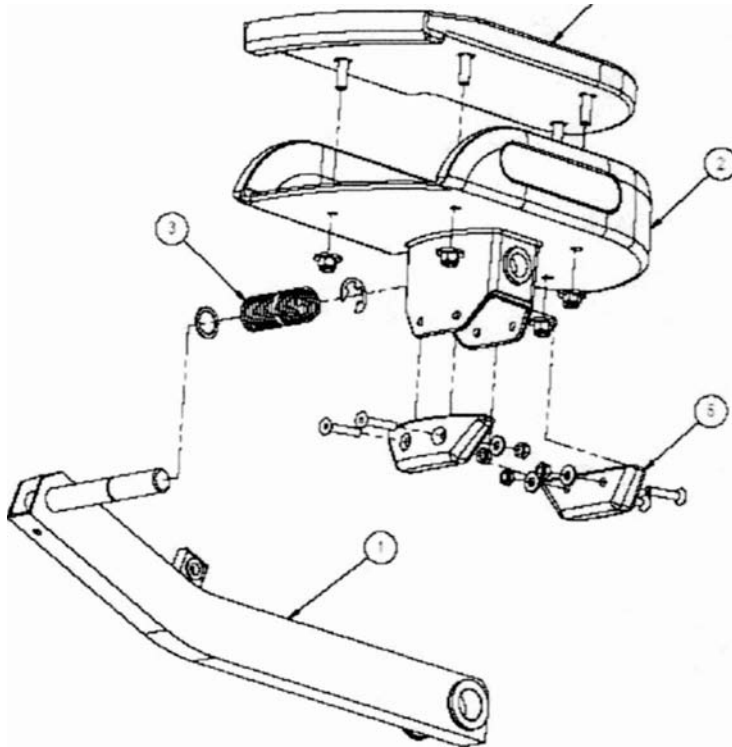

Drawing

711-1045-02 Pedal assy Right

ITEM NO.	PART NO.	DESCRIPTION	QTY
1	711-3173-02	ASSY. PEDAL ARM W/ BUSHING, RIGHT	1
2	711-3174-02	ASSY. PEDAL W/ BUSHING, RIGHT	1
3	711-3175	KIT, SPRING FOOT PIVOT	1
4	711-3176-02	KIT, PEDAL PAD, RIGHT	1
5	711-3177	KIT, PEDAL STOPS, 5100 STEPPER	1

Part Assemblies - Chain Link Assembly

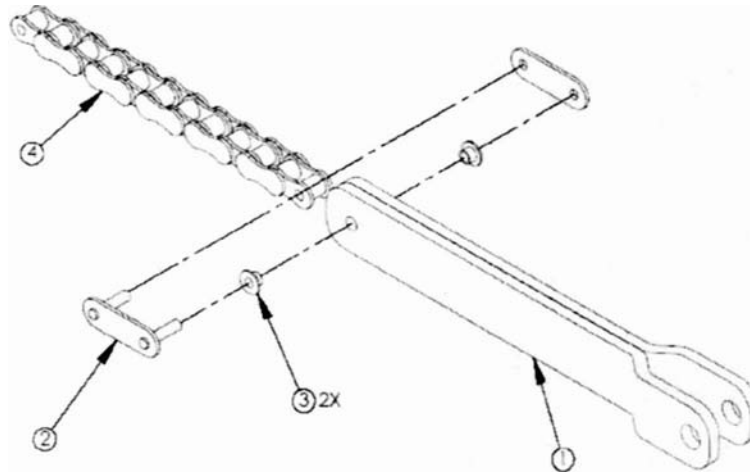

ITEM	PART NO.	DESCRIPTION	QTY
1	020-6810	WELDMENT, CONN, CHAIN, STEPPER	1
2	130-1543	LINK, CONN, CHAIN	2
3	130-1636	BEARING, IGLIDE, 4MMx4MM	2
4	130-1641	CHAIN, 40 NPX, .5 PIT, 14.5 L	

Part Assemblies - Electrical Components

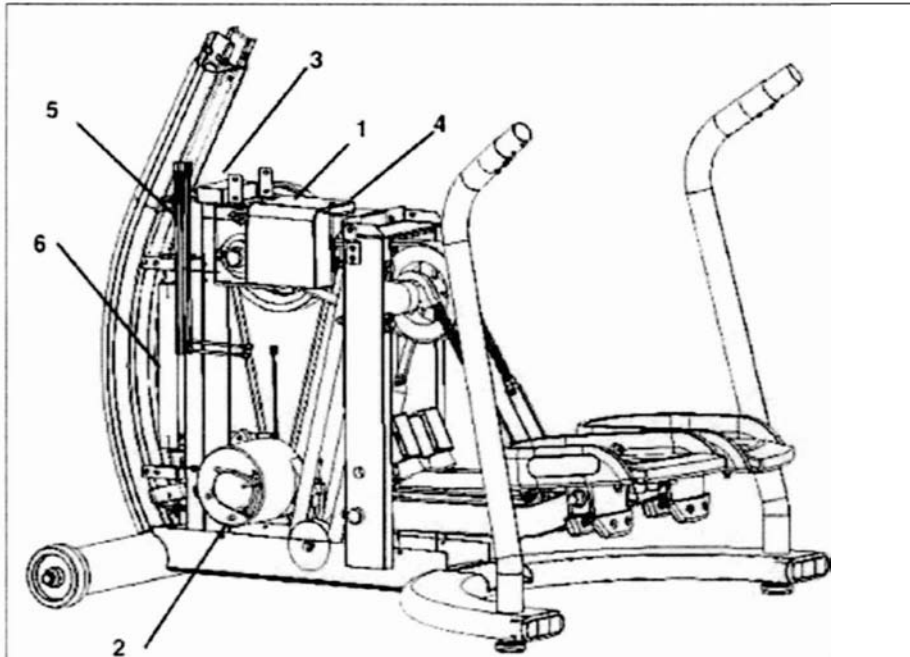

Electrical Components

ITEM NO	PART NUMBER	DESCRIPTION	QTY
1	020-6748	Shroud . Left , Stepper	1
2	800-3122	All , Mando , Raw All no Pullev	1
3	800-3102	Battery , 6v, Ub/RblSc	1
4	711-3162	Assy , Lcb Stepper	1
5	711-3166	Cable . Alt And Lcb, Stepper	1
6	711-3167	Cable . Resistor, Stepper	1

Part Assemblies - Frame Assembly Right

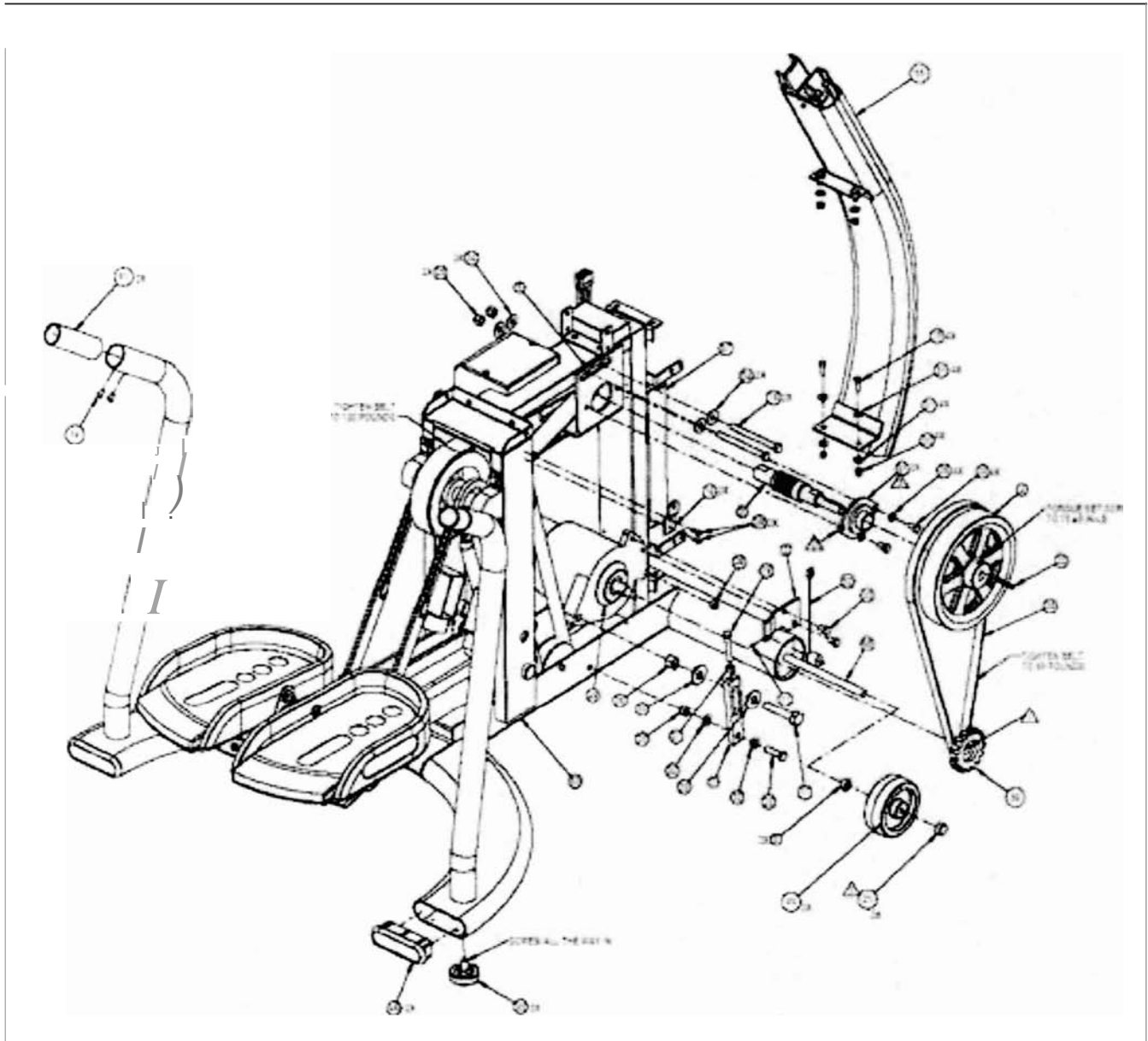

Part Assemblies - Frame Assembly Left

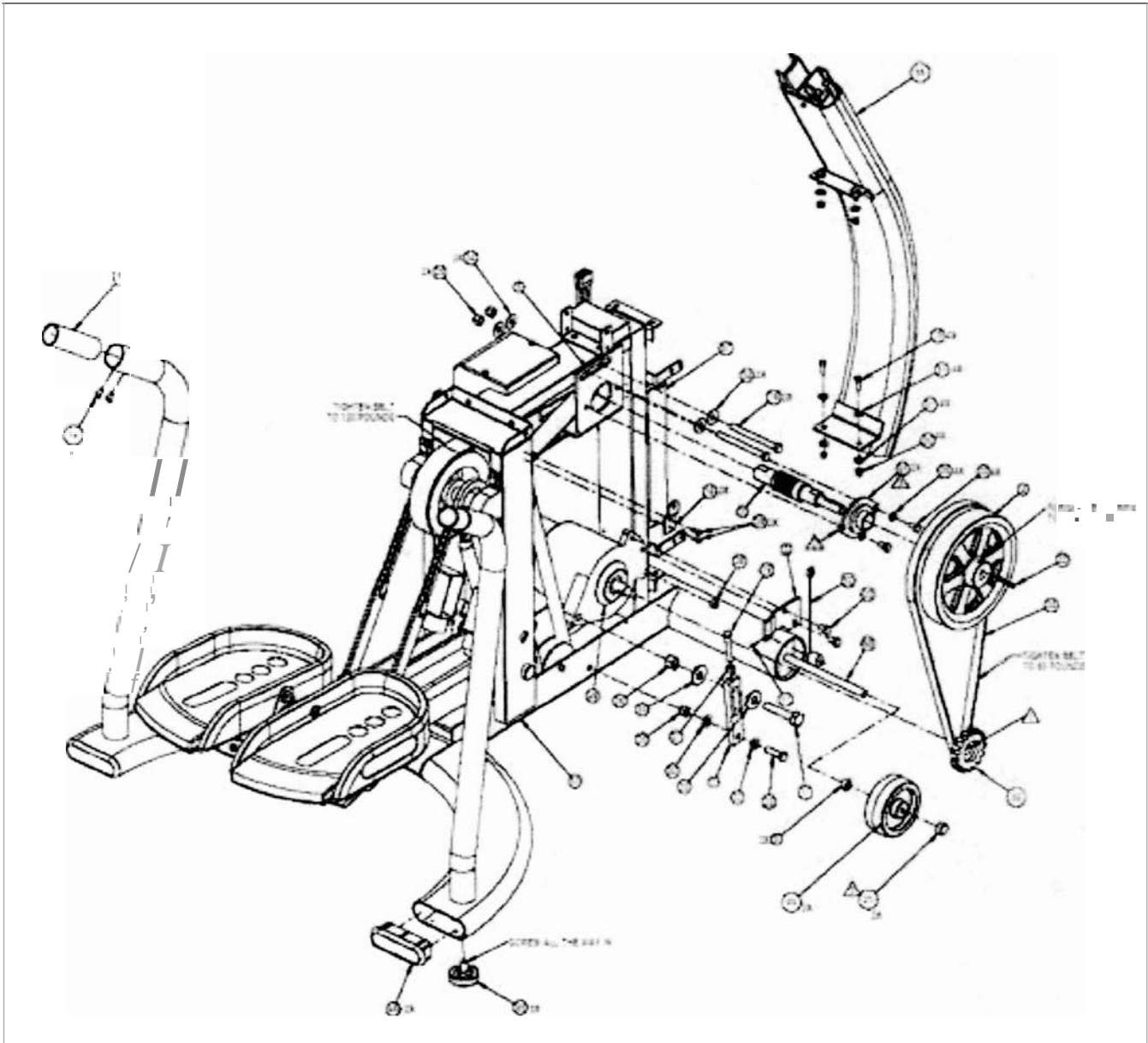



Pro Stepper Service Manual

Part Assemblies - Frame Assembly Parts list

ITEM NO.	PART NO.	DESCRIPTION	QTY
	020-0021	BRACKET ALTERNATOR ADJUST	1
	020-0023	BRACKET RPM SENSOR/ALTERNATOR	1
	020-0141	SHAFT/PLEY 16/130 STP	1
	020-068	FLYWHEEL 3" J' OD X 625 D	1
	020-0690	BRACKET ADJUSTABLE	1
	020-4604	SPACER 1.2 ID X 3/4 OD X 3 1/2 L	1
	020-4748	COVER LOWER JARD STEPPER	1
8	020-4883	BRACKET S. ROUD MOUNT STEP	1
1	020-4858	BRACKET SHROUD STEP-2	1
10	020-4859	BRACKET SHROUD S EP-3	2
	110-0133	SCREW #6-32x1/4 SHC -, AS NP	
12	110-0280	SCREW #6-32x1/8 PHM SLCS ZI	
13	110-050	SCREW 1/4-20x3/25 HHC CS ZP	1
14	110-0502	SCREW 1/4-28x3/8 BHSS SS BLKID	
	10-0-1-1	S. REW #4-2 X 3/4 -- -- HECS ZP	
16	110-060	SCREW 3/8-16x1/2 SHC HECS ZP	
1	110-0610	BOLT 1/2-13x2 1/2 HHC HECS ZI	1
18	110-0652	BOLT 5/16-18x1/2 HHC HECS ZP	1
19	110-0696	BOLT 5/16-18 X 2 0" HHC FULL THRD	
20	110-0687	SCREW 5/16-18x1/2 HHC HECS Z	6
	110-1415	CAP 1/2 PUSH ON	
22	110-1442	KEY MACHINE 3 16X3 16X 5'	
..	110-1530	SCREW 3/8-16x1/25 HHC HECS Z	
24	110-1740	NUT 6-32 KEP	
	110-1830	NUT 3/8-16 NYLOK HEX	3
26	110-1833	NUT 1/2-13 NYLOK HEX	1
27	110-1870	NUT 5/16-8 KEPS	1
28	110-1871	NUT 5/16-18 NYLOC	1
..	110-3026	SCREW 1/2-24X 50 PF-TCS	16
30	110-3096	NUT 1/4-20 HEX NYLOC	
31	120-0410	WASHER 1/4 SAE FLAT	
32	120-0460	WASHER 3/8 SAE FLAT	
33	120-0462	WASHER 1/2 FLAT 9 16ID 1-3 80D	2
34	120-0463	WASHER 3/8 X 1 OD	
35	120-0480	WASHER 5/16 X 7/8 OD 067 THK	
36	120-0495	WASHER 5/16 SPL T LOCK	
37	20-0900	SPACER #8 1/4" OD x 1/2" L N	
38	130-0123	BELT R450/7 POLY VEE	
39	130-1302	DRIVE PULLEY 7/130 STEPPER	1
40	130-894	WHEEL 1 1/2" OD X 0.5" BORE	
41	130-7008	FLANGE BEARING ASSY	
42	40-0210	STRAP 3 5	2
43	140-0490	TAPE VELCRO -HOOKS	5 FT
44	140-0492	TAPE VELCRO LOOPS	5 FT
45	140-3247	LEVELER FEET ADJUSTMENT	
46	140-3310	END CAP STEP BASE	2
47	140-3325	TIE MT 2-WAY EX 1/2"	
48	170-0688	BRACKET RESISTOR	
49	260-0133	ALTERNATOR MONDO	
50	580-0275	WIRE BERRY 6V NP	
51	710-0521	INSERT SIDERAIL UNIVERSAL	
	711-0225	RPM SENSOR COIL ASSY STEPPER	
53	711-3 55	KIT STEP FRAME	
54	711-3162	ASSY LOWER STEPPER	
	711-3163	ASSY BASE NECK STEPPER	1
56	711-3166	CABLE ALT AND LOWER STEP 5100	1
57	711-316	CABLE RESISTOR STEPPER	1
58	115-3430	AXLE ELEVATION PRO TR	1



Part Assemblies - Frame Assembly

Drawing # 711-3155
Frame
Assembly

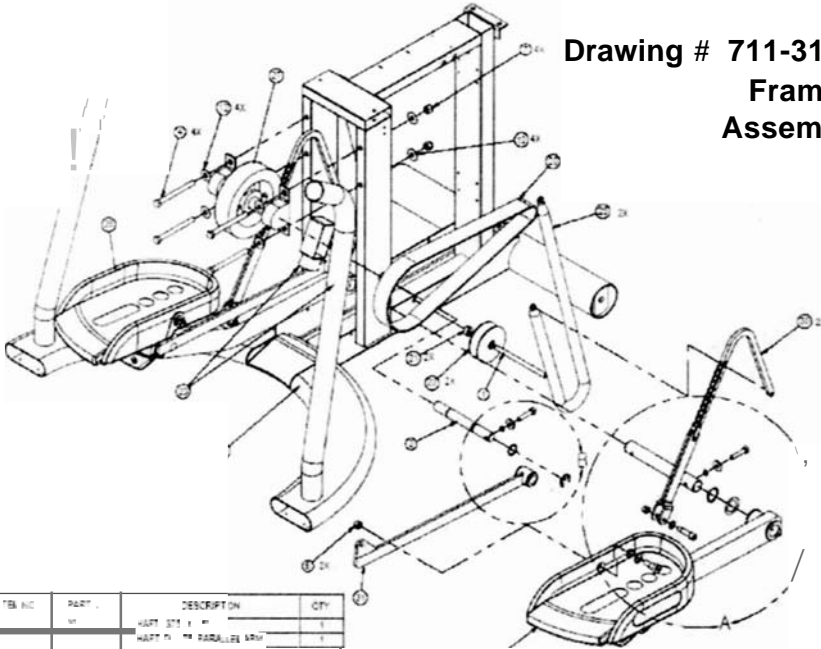

PART NO.	PART	DESCRIPTION	QTY
1	8000	WFT STE	1
2	8000	WFT STE	1
3	8000	WFT STE	1
4	8000	WFT STE	1
5	8000	WFT STE	1
6	8000	WFT STE	1
7	8000	WFT STE	1
8	8000	WFT STE	1
9	8000	WFT STE	1
10	8000	WFT STE	1
11	8000	WFT STE	1
12	8000	WFT STE	1
13	8000	WFT STE	1
14	8000	WFT STE	1
15	8000	WFT STE	1
16	8000	WFT STE	1
17	8000	WFT STE	1
18	8000	WFT STE	1
19	8000	WFT STE	1
20	8000	WFT STE	1
21	8000	WFT STE	1
22	8000	WFT STE	1
23	8000	WFT STE	1
24	8000	WFT STE	1
25	8000	WFT STE	1
26	8000	WFT STE	1
27	8000	WFT STE	1
28	8000	WFT STE	1
29	8000	WFT STE	1
30	8000	WFT STE	1
31	8000	WFT STE	1
32	8000	WFT STE	1
33	8000	WFT STE	1
34	8000	WFT STE	1
35	8000	WFT STE	1
36	8000	WFT STE	1
37	8000	WFT STE	1
38	8000	WFT STE	1
39	8000	WFT STE	1
40	8000	WFT STE	1
41	8000	WFT STE	1
42	8000	WFT STE	1
43	8000	WFT STE	1
44	8000	WFT STE	1
45	8000	WFT STE	1
46	8000	WFT STE	1
47	8000	WFT STE	1
48	8000	WFT STE	1
49	8000	WFT STE	1
50	8000	WFT STE	1
51	8000	WFT STE	1
52	8000	WFT STE	1
53	8000	WFT STE	1
54	8000	WFT STE	1
55	8000	WFT STE	1
56	8000	WFT STE	1
57	8000	WFT STE	1
58	8000	WFT STE	1
59	8000	WFT STE	1
60	8000	WFT STE	1
61	8000	WFT STE	1
62	8000	WFT STE	1
63	8000	WFT STE	1
64	8000	WFT STE	1
65	8000	WFT STE	1
66	8000	WFT STE	1
67	8000	WFT STE	1
68	8000	WFT STE	1
69	8000	WFT STE	1
70	8000	WFT STE	1
71	8000	WFT STE	1
72	8000	WFT STE	1
73	8000	WFT STE	1
74	8000	WFT STE	1
75	8000	WFT STE	1
76	8000	WFT STE	1
77	8000	WFT STE	1
78	8000	WFT STE	1
79	8000	WFT STE	1
80	8000	WFT STE	1
81	8000	WFT STE	1
82	8000	WFT STE	1
83	8000	WFT STE	1
84	8000	WFT STE	1
85	8000	WFT STE	1
86	8000	WFT STE	1
87	8000	WFT STE	1
88	8000	WFT STE	1
89	8000	WFT STE	1
90	8000	WFT STE	1
91	8000	WFT STE	1
92	8000	WFT STE	1
93	8000	WFT STE	1
94	8000	WFT STE	1
95	8000	WFT STE	1
96	8000	WFT STE	1
97	8000	WFT STE	1
98	8000	WFT STE	1
99	8000	WFT STE	1
100	8000	WFT STE	1

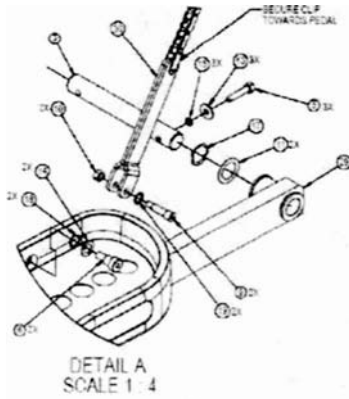
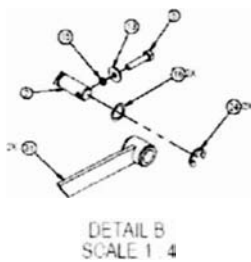



Pro Stepper Service Manual

Maintenance Log



Model, _____ Serial Number _____ Mfg Date _____

Date	Cleaning	Problem/Adjustment	Part Replaced	Service performed by
------	----------	--------------------	---------------	-------------------------

Comments:





Pro Stepper Service Manual

Warranty

STAR TRAC LIMITED WARRANTY COMMERCIAL FITNESS PRODUCTS

STAR TRAC by DYNISE, INC. warrants to the original purchaser that its Commercial Fitness Products are free of defects in workmanship and materials. Parts are covered for a period of two (2) years from date of purchase. Sport Treadmill, TR4500 Treadmill, and Pro S Treadmill drive motors and motor control boards are covered for a period of three (3) years from date of purchase. P.O.Treadmill and Elite Treadmill drive motors and motor control boards are covered for a period of five (5) years from date of purchase. Frame welds are warranted for the life of the product. Treadmill wear items, such as running belt, running deck, and me: brushes are warranted for six (6) months from date of purchase (see Exclusions, below). Other wear items, such as bicycle seat upholstery and handlebar grips are warranted for one (1) year from date of purchase (see Exclusions, below). During the applicable warranty period, Star Trac will either repair or replace, at its option defective part(s) at no charge. Additionally, Star Trac will cover labor costs for required repairs of Sport Treadmill, TR4500 Treadmill, and Pro S Treadmill drive motors and motor control boards for a period of three (3) years from date of purchase. Star Trac will cover labor costs for required repairs of Pro Treadmill and Elite Treadmill drive motors and motor control boards for a period of five (5) years from date of purchase. Star Trac will cover labor costs for required repairs of non wear item parts for a period of one (1) year from date of purchase. Star Trac will cover labor costs for required repairs of wear item parts for a period of six (6) months from date of purchase. The manufacturer does not warrant the heart rate system performance on this product, as the heart rate system performance varies, based on a user's physiology, fitness level, age, method of use and other factors. Furthermore, the heart rate system is not for medical use.

In order to implement the provisions of this limited warranty, the original purchaser must contact Star Trac Product Support at (800)503-1221. Be prepared to provide the product serial number and a detailed description of the problem. Proof of purchase or warranty registration will be needed to verify warranty effectiveness and obtain warranty service and/or parts. Do not return defective part(s) for repair or replacement without prior authorization from Star Trac.

Star Trac reserves the right to review defective part(s). All costs of shipping defective part(s) to and from Star Trac for inspection shall be borne solely by the original purchaser. Any repair or modification of defective part(s) by anyone other than a Star Trac Technical Representative or Authorized Service Provider will void this warranty. If Star Trac determines, in its sole discretion, that it is impractical to ship defective part(s) to Star Trac, Star Trac may designate, in its sole discretion, a repair facility to inspect and estimate the cost to repair such defective part(s). The cost, if any, of shipping defective part(s) to and from such repair facility and/or such estimates shall be borne solely by the original consumer purchaser. Defective part(s) must remain available for inspection until the claim is finalized. Whenever claims are settled, Star Trac reserves the right to be subrogated under any existing insurance policies the claimant may have.

Exclusions

For Sport treadmills, TR4500 Treadmills, and Pro S Treadmills, running belt waxing is the original purchaser's responsibility. For all treadmills tracking and tension adjustments are the original purchaser's responsibility. Running belts that have separated due to heel and belts with chaffed edges or creases caused by folding will not be covered. This limited warranty does not apply to cosmetic damage, imperfections that are within design specification(s) or that do not materially affect functionality, or damage due to acts of God, accident, abuse, misuse, negligence, lack of normal maintenance, abnormal service or handling that differs from that specified for this model, improper installation or operation. In addition, alteration or modification of the product, or repair by anyone other than a Star Trac technical representative or authorized service provider will void this warranty. This warranty is valid only in the continental United States.

Disclaimer of Warranties; Limitation of Liability

This warranty is in lieu of all other warranties, express or implied, including without limitation, the implied warranties of merchantability and fitness for a particular purpose. Repair or replacement as provided above shall be the sole and exclusive remedy available to the purchaser. Correction of defects, in the manner and for the period of time described above, shall constitute complete fulfillment of all liabilities and responsibilities of Star Trac to the purchaser with respect to contract, negligence, strict liability or otherwise. Star Trac shall not be liable or in any way responsible for any incidental or consequential damages based upon breach of any express or implied warranty on this product or otherwise.

Some states do not allow the exclusion or limitation of implied warranties or incidental or consequential damages, so the above exclusions and limitations may not apply to you. This warranty gives you specific legal rights, and you may also have other rights, which may vary, from state to state.

PIN: 620-7135, REVISION: E, DOC. WARRANTY COMMERCIAL

Effective August 2004



800-503-1221

<http://support.startrac.com/>