

# **NordicTrack**<sup>®</sup> **X9i** INCLINE TRAINER

[www.nordictrack.com](http://www.nordictrack.com)

Model No. NTL19010.2

Serial No. \_\_\_\_\_

Write the serial number in the space above for reference.

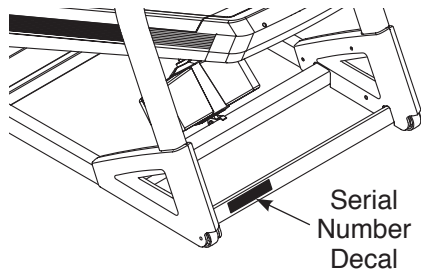

## QUESTIONS?

If you have questions, or if parts are damaged or missing, **DO NOT CONTACT THE STORE**; please contact Customer Care.

**IMPORTANT:** Please register this product (see the limited warranty on the back cover of this manual) before contacting Customer Care.

CALL TOLL-FREE:

**1-800-TO-BE-FIT**

(1-800-862-3348)

Mon.–Fri. 6 a.m.–6 p.m. MT

Sat. 8 a.m.–4 p.m. MT

ON THE WEB:

[www.nordictrackservice.com](http://www.nordictrackservice.com)

## USER'S MANUAL



## CAUTION

Read all precautions and instructions in this manual before using this equipment. Save this manual for future reference.



# TABLE OF CONTENTS

WARNING DECAL PLACEMENT .....	2
IMPORTANT PRECAUTIONS .....	3
BEFORE YOU BEGIN .....	5
PART IDENTIFICATION CHART .....	6
ASSEMBLY .....	7
THE CHEST HEART RATE MONITOR .....	13
OPERATION AND ADJUSTMENT .....	14
HOW TO MOVE THE INCLINE TRAINER .....	27
TROUBLESHOOTING .....	28
EXERCISE GUIDELINES .....	31
PART LIST .....	33
EXPLODED DRAWING .....	35
ORDERING REPLACEMENT PARTS .....	Back Cover
LIMITED WARRANTY .....	Back Cover

## WARNING DECAL PLACEMENT

This drawing shows the locations of the warning decals. **If a decal is missing or illegible, call the telephone number on the front cover of this manual and request a free replacement decal. Apply the decal in the location shown. Note: The decals may not be shown at actual size.**

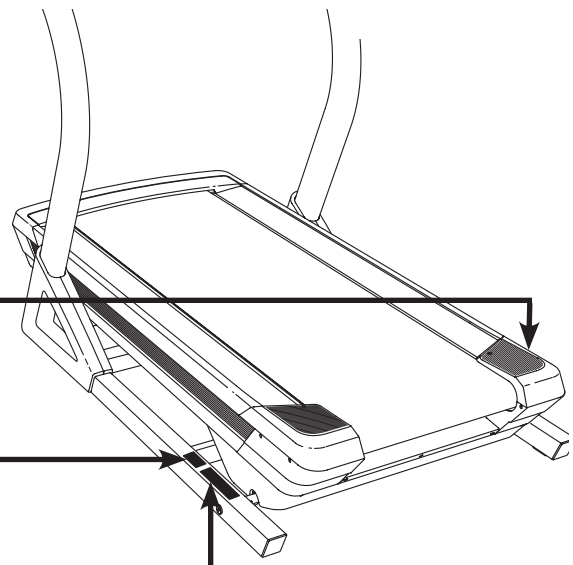

**▲WARNING:** Protect yourself and others from risk of serious injury. Read the user's manual or obtain proper instruction before use and:

<ul style="list-style-type: none"> <li>• Stand only on side rails when starting or stopping treadmill.</li> <li>• Change speed in small increments.</li> <li>• Hold handrails to prevent falling, and always wear the safety clip while operating treadmill.</li> <li>• Stop if you feel faint, dizzy, or short of breath.</li> </ul>		<ul style="list-style-type: none"> <li>• Never allow children on or around treadmill.</li> <li>• Remove key when not in use.</li> </ul>		<ul style="list-style-type: none"> <li>• Keep clothing, fingers, and hair away from moving belt.</li> <li>• Never try to adjust or fix the belt while it is moving.</li> <li>• Always wear athletic shoes while operating treadmill.</li> </ul>	
---	--	---	--	---	--

# IMPORTANT PRECAUTIONS

**⚠ WARNING:** To reduce the risk of serious injury, read all important precautions and instructions in this manual and all warnings on your incline trainer before using your incline trainer. ICON assumes no responsibility for personal injury or property damage sustained by or through the use of this product.

1. Before beginning any exercise program, consult your physician. This is especially important for persons over age 35 or persons with pre-existing health problems.
2. It is the responsibility of the owner to ensure that all users of this incline trainer are adequately informed of all warnings and precautions.
3. Use the incline trainer only as described.
4. Keep the incline trainer indoors, away from moisture and dust. Do not put the incline trainer in a garage or covered patio, or near water.
5. Place the incline trainer on a level surface, with at least 8 ft. (2.4 m) of clearance behind it and 2 ft. (0.6 m) on each side. Do not place the incline trainer on any surface that blocks air openings. To protect the floor or carpet from damage, place a mat under the incline trainer.
6. Do not operate the incline trainer where aerosol products are used or where oxygen is being administered.
7. Keep children under age 12 and pets away from the incline trainer at all times.
8. The incline trainer should be used only by persons weighing 350 lbs. (159 kg) or less.
9. Never allow more than one person on the incline trainer at a time.
10. Wear appropriate exercise clothes while using the incline trainer. Do not wear loose clothes that could become caught in the incline trainer. Athletic support clothes are recommended for both men and women. *Always wear athletic shoes. Never use the incline trainer with bare feet, wearing only stockings, or in sandals.*
11. Plug the power cord into a surge suppressor (not included), and plug the surge suppressor into an appropriate outlet (see page 14). To avoid overloading the circuit, do not plug other electrical devices, except for low-power devices such as cell phone chargers, into the surge suppressor or into an outlet on the same circuit.
12. Use only a surge suppressor that meets all of the specifications described on page 14. To purchase a surge suppressor, see your local NORDICTRACK dealer, call the telephone number on the front cover of this manual, or see your local electronics store.
13. Failure to use a properly functioning surge suppressor could result in damage to the control system of the incline trainer. If the control system is damaged, the walking belt may slow, accelerate, or stop unexpectedly, which may result in a fall and serious injury.
14. Keep the power cord and the surge suppressor away from heated surfaces.
15. Never move the walking belt while the power is turned off. Do not operate the incline trainer if the power cord or plug is damaged, or if the incline trainer is not working properly. (See TROUBLESHOOTING on page 28 if the incline trainer is not working properly.)
16. Read, understand, and test the emergency stop procedure before using the incline trainer (see HOW TO TURN ON THE POWER on page 16).
17. Never start the incline trainer while you are standing on the walking belt. Always hold the handrails while using the incline trainer.
18. The incline trainer is capable of high speeds. Adjust the speed in small increments to avoid sudden jumps in speed.

19. The heart rate monitor is not a medical device. Various factors, including the user's movement, may affect the accuracy of heart rate readings. The heart rate monitor is intended only as an exercise aid in determining heart rate trends in general.
20. Never leave the incline trainer unattended while it is running. Always remove the key, unplug the power cord, and press the power switch into the off position when the incline trainer is not in use. (See the drawing on page 5 for the location of the power switch.)
21. Do not attempt to move the incline trainer until it is properly assembled. (See ASSEMBLY on page 7, and HOW TO MOVE THE INCLINE TRAINER on page 27.) You must be able to safely lift 45 lbs. (20 kg) to raise, lower, or move the incline trainer.
22. Never insert any object into any opening on the incline trainer.
23. Inspect and properly tighten all parts of the incline trainer regularly.
24. **DANGER:** Always unplug the power cord immediately after use, before cleaning the incline trainer, and before performing the maintenance and adjustment procedures described in this manual. Never remove the motor hood unless instructed to do so by an authorized service representative. Servicing other than the procedures in this manual should be performed by an authorized service representative only.
25. This incline trainer is intended for home use only. Do not use this incline trainer in a commercial, rental, or institutional setting.
26. Over exercising may result in serious injury or death. If you feel faint or if you experience pain while exercising, stop immediately and cool down.

**SAVE THESE INSTRUCTIONS**

# BEFORE YOU BEGIN

Thank you for selecting the revolutionary NORDICTRACK® INCLINE TRAINER X9i INTERACTIVE. The INCLINE TRAINER X9i INTERACTIVE offers a selection of features designed to make your workouts at home more enjoyable and effective.

**For your benefit, read this manual carefully before using the incline trainer.** If you have questions after

reading this manual, please see the front cover of this manual. To help us assist you, note the product model number and serial number before contacting us. The model number and the location of the serial number decal are shown on the front cover of this manual.

Before reading further, please familiarize yourself with the parts that are labeled in the drawing below.

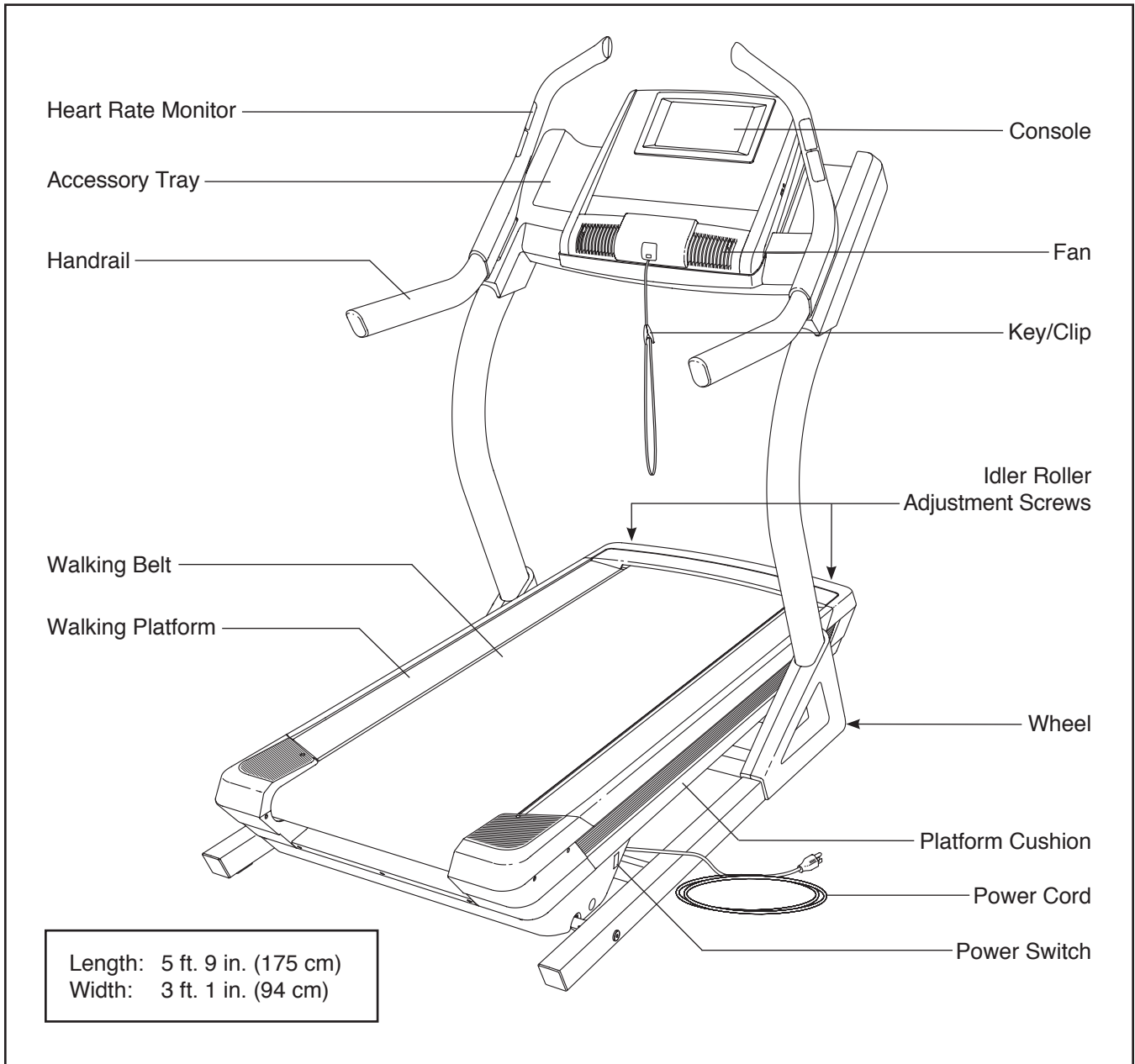

# PART IDENTIFICATION CHART

Use the drawings below to identify small parts used for assembly. The number in parentheses below each drawing is the key number of the part, from the PART LIST near the end of this manual. The number following the key number is the quantity used for assembly. **Note: If a part is not in the hardware kit, check to see if it is pre-tapped. Extra hardware may be included.**

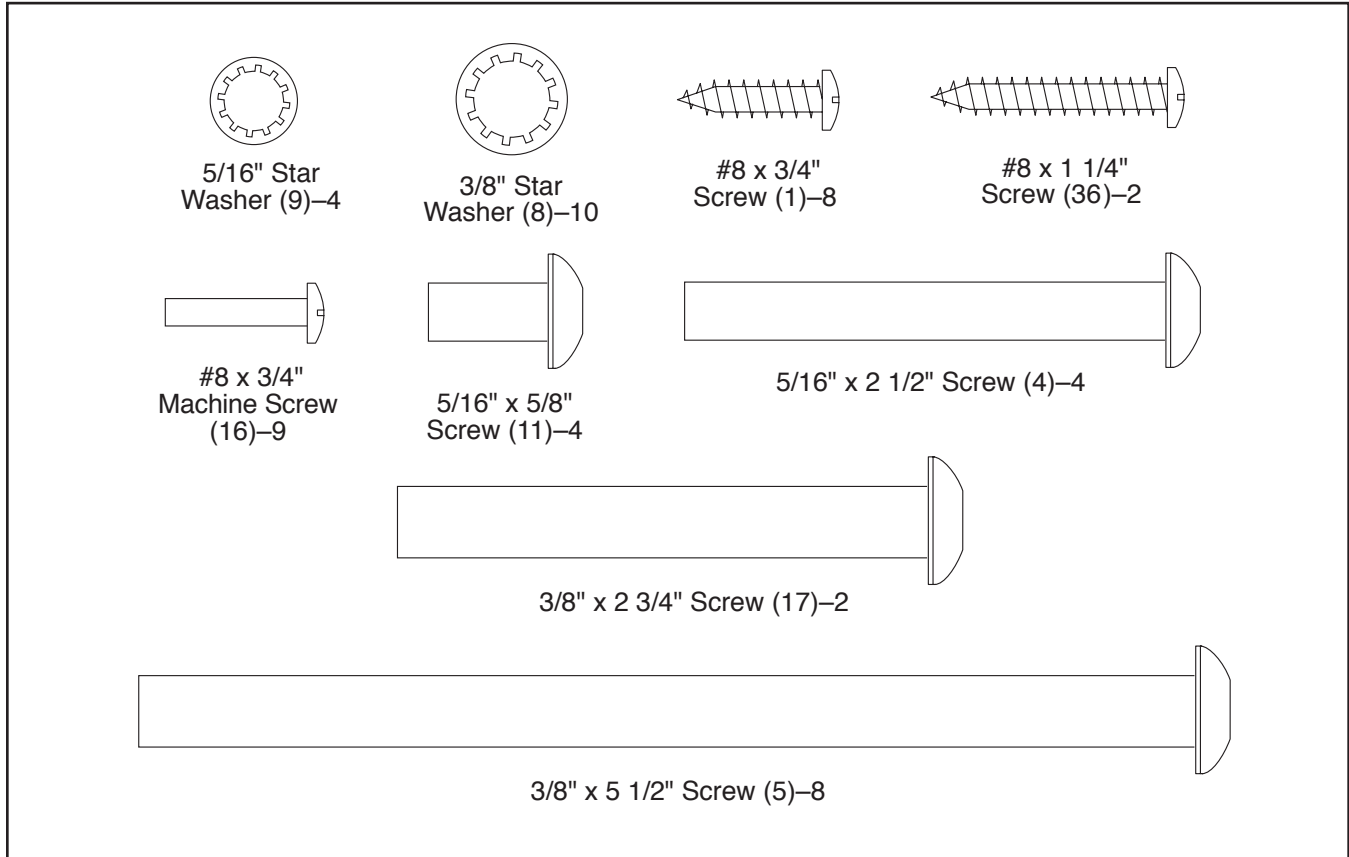

# ASSEMBLY

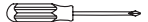
- Assembly requires two persons.
- Place all parts in a cleared area and remove the packing materials. Do not dispose of the packing materials until you finish all assembly steps.
- The underside of the walking belt is coated with high-performance lubricant. After shipping, there may be some lubricant on top of the walking belt or on the shipping carton. This is normal. If there is lubricant on top of the walking belt, wipe it off with a soft cloth and a mild, non-abrasive cleaner.
- To identify small parts, see page 6.
- Assembly requires the following tools:
  - the included hex keys 
  - one Phillips screwdriver 
- To avoid damaging parts, do not use power tools.

## 1. Make sure that the power cord is unplugged.

Identify the right Upright (77), which has a wire tie in it. Hold the Upright near the right side of the incline trainer.

**See the inset drawing.** Tie the wire tie in the right Upright (77) around the end of the Upright Wire (78). Then, pull the other end of the wire tie until the Upright Wire is routed out of the top of the Upright.

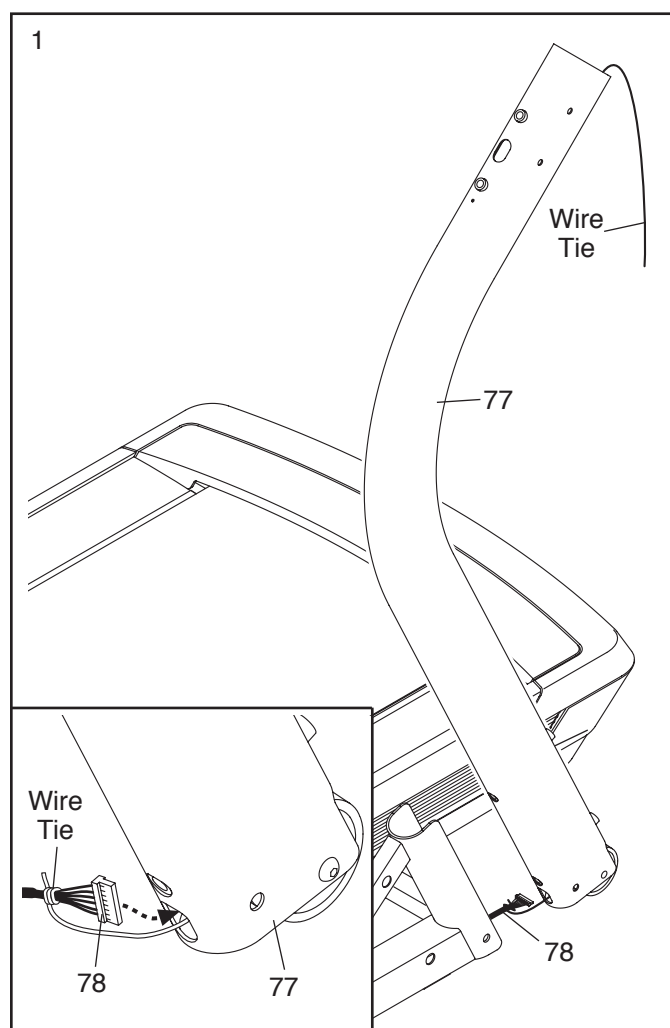

2. Attach the Upright (77) to the Base (80) with two  $3/8" \times 5 1/2"$  Screws (5) and a  $3/8" \times 2 3/4"$  Screw (17) with three  $3/8"$  Star Washers (8) as shown. **Start all three Screws, and then tighten them. Be careful not to pinch the Upright Wire (not shown) in the Upright.**

**Attach the other Upright (not shown) as described above.** Note: There is not a wire on the left side.

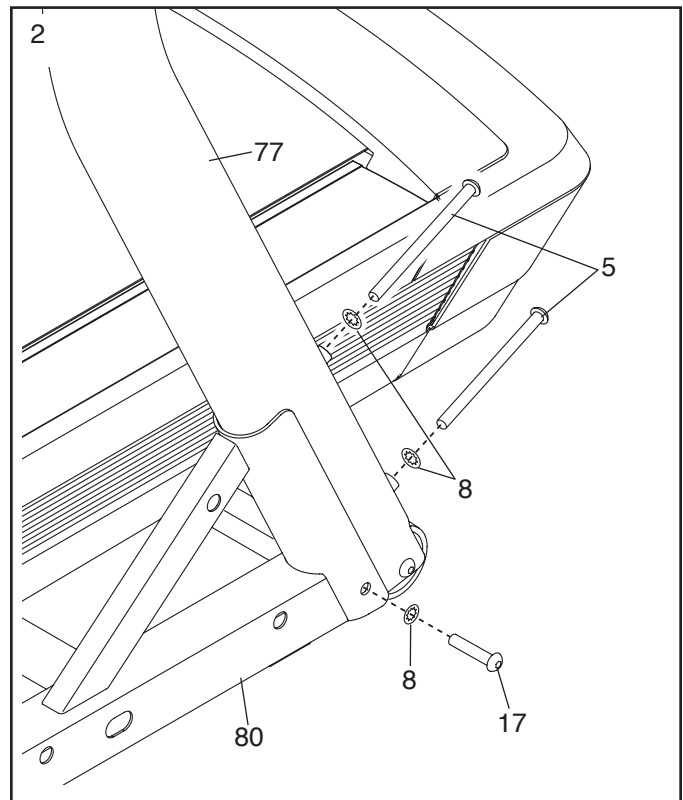

3. Set the Console (37) face down on a soft surface to avoid scratching the Console. Remove and discard the four screws (A) from the Console Base Back (89). Lift off the Console Base Back.

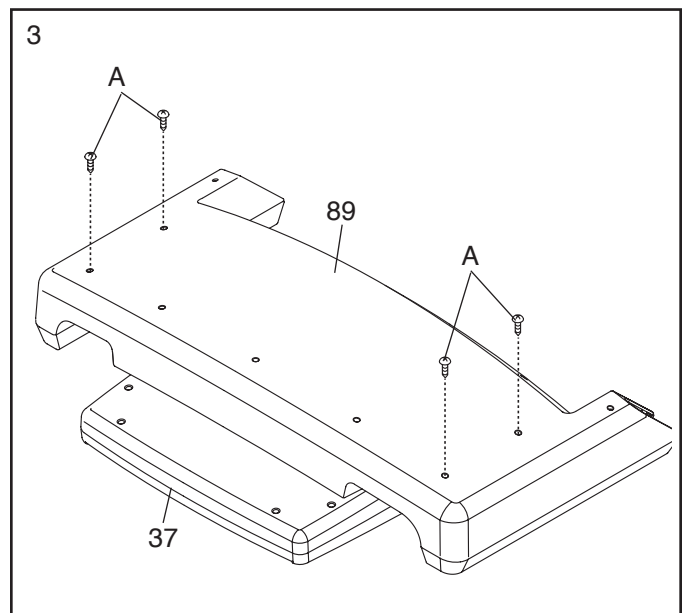



4. Have a second person hold the console assembly near the Uprights (77). Insert the console wire and the "R" pulse wire from the console assembly through the indicated tie.

Connect the Upright Wire (78) to the console wire. **See the inset drawing. The connectors should slide together easily and snap into place.** If they do not, turn one connector and try again. **IF YOU DO NOT CONNECT THE CONNECTORS PROPERLY, THE CONSOLE MAY BECOME DAMAGED WHEN YOU TURN ON THE POWER.**

Remove the wire tie from the Upright Wire (78).

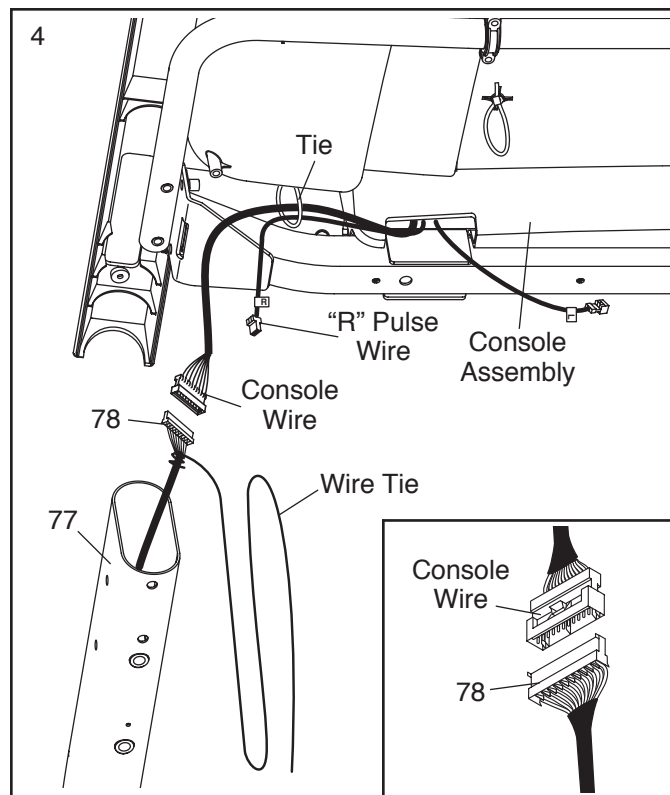

5. Insert the Upright Wire (78) into the right Upright (77) as you insert the Console Crossbar (101) into the Uprights. **Be careful not to pinch the Upright Wire.**

Loosen the four #8 x 1" Screws (102) (only two are shown) one turn.

Tighten two 5/16" x 2 1/2" Screws (4) with two 5/16" Star Washers (9) into the side of the right Upright (77) and into the Crossbar (103). **Do not overtighten the Screws. Be careful not to pinch the Upright Wire (78).**

Next, tighten two 5/16" x 5/8" Screws (11) into the right Upright (77) and the Console Crossbar (101). **It may be necessary to slide the Console Crossbar (101) to align the holes.** Then, tighten the two #8 x 1" Screws (102).

**Repeat this step on the other side of the incline trainer.**

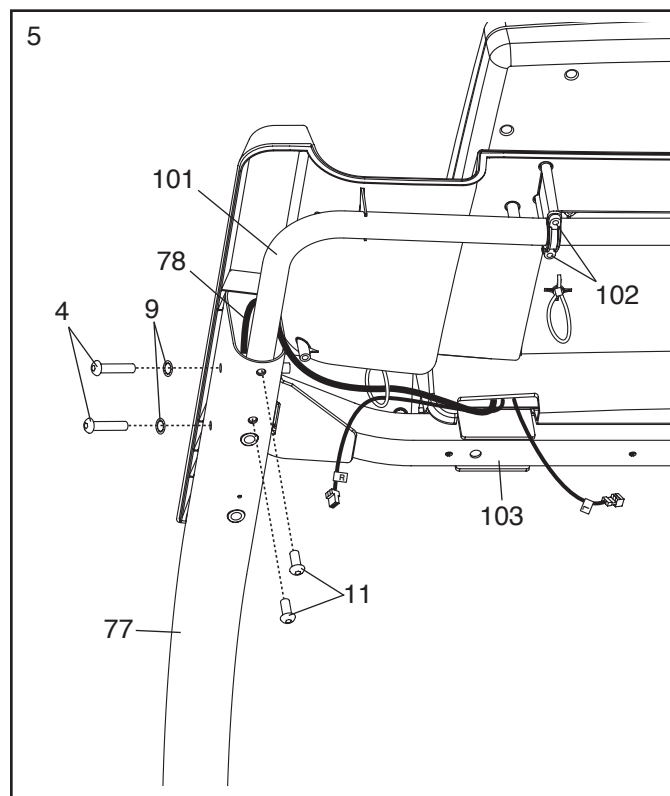

6. Tighten two #8 x 3/4" Screws (1) into the Console Base (87). **Do not overtighten the Screws.**

Identify the Right Handrail Assembly (93). Hold the Right Handrail Assembly near the right Upright (77). Insert the pulse wire from the Right Handrail Assembly into the hole in the top of the Upright and pull it out of the end of the Upright.

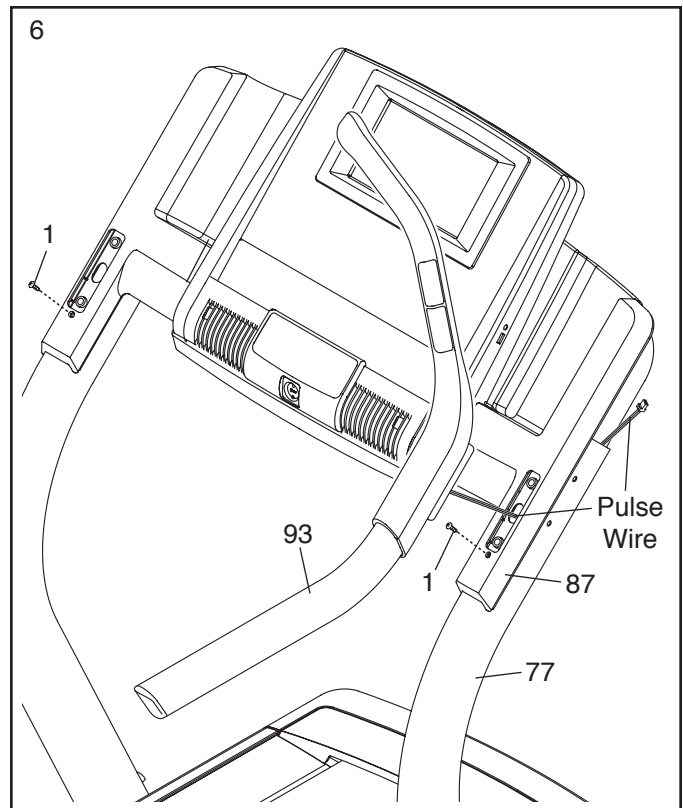

7. Set the Right Handrail Assembly (93) onto the right Upright (77). **Make sure that no wires are pinched.**

Attach the Right Handrail Assembly (93) with two 3/8" x 5 1/2" Screws (5) and two 3/8" Star Washers (8). **Note: Start the lower Screw first.**

Then, connect the two "R" pulse wires.

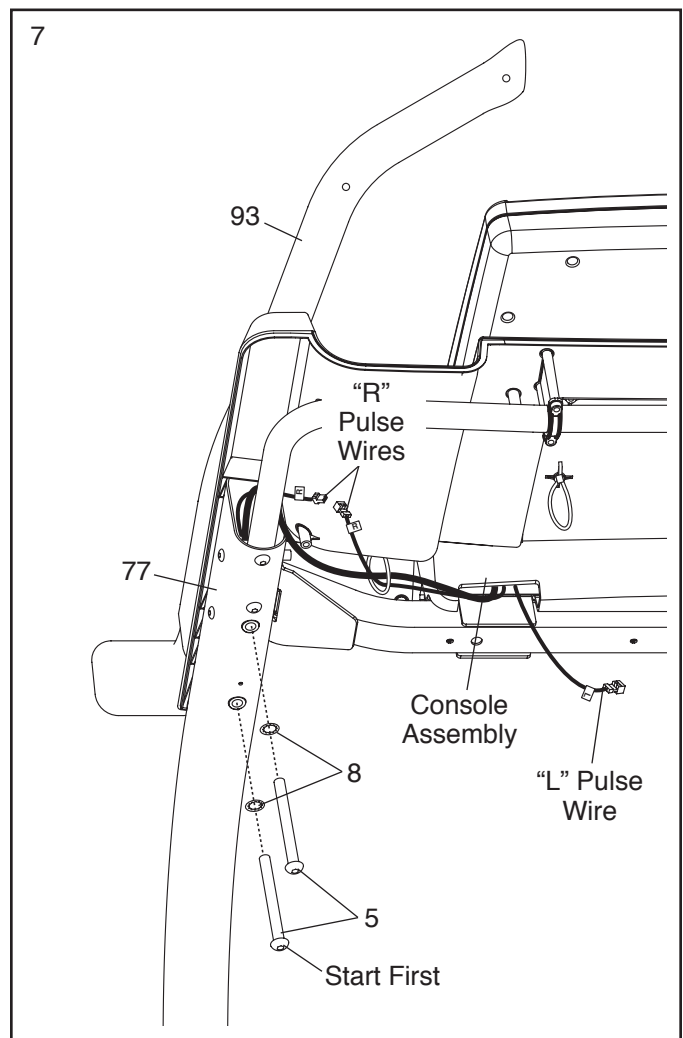

8. Hold the Left Handrail Assembly (86) near the left Upright (77). Insert the pulse wire from the left handrail assembly into the hole in the top of the Upright and pull it out of the end of the Upright.

Set the Left Handrail Assembly (86) onto the left Upright (77). **Make sure that no wires are pinched.**

Attach the Left Handrail Assembly (86) with two 3/8" x 5 1/2" Screws (5) and two 3/8" Star Washers (8). **Note: Start the lower Screw first.**

Insert the pulse wire through the three ties (only two are shown). Connect the two "L" pulse wires (see step 7).

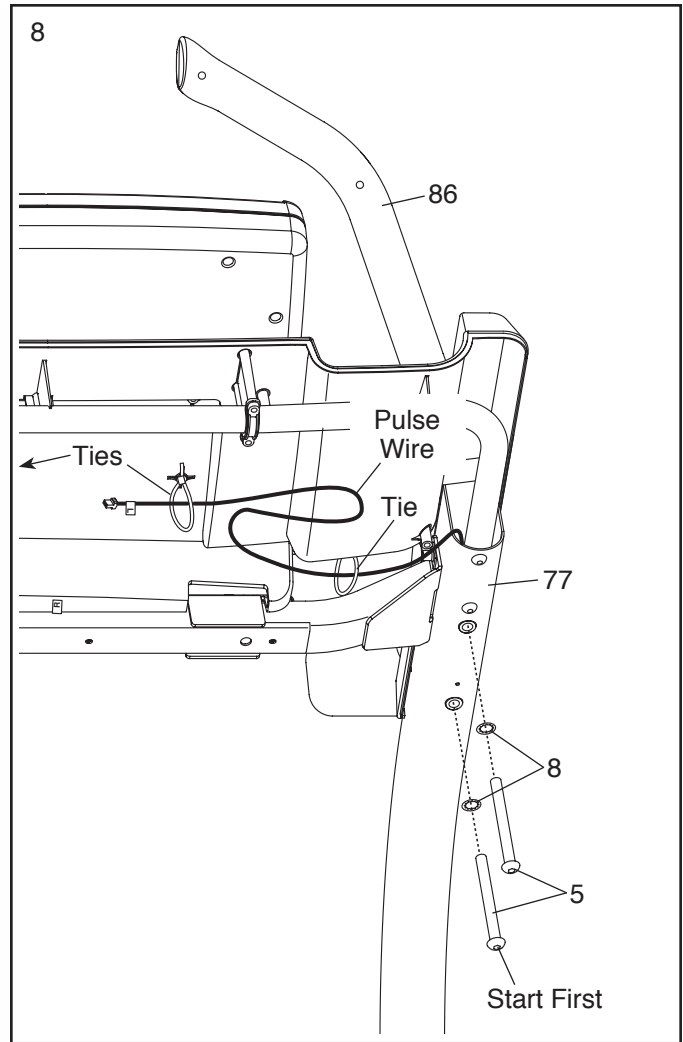

9. Attach the Console Base Back (89) to the Console Base (87) with nine #8 x 3/4" Machine Screws (16) and two #8 x 3/4" Screws (1) in the locations shown. **Start all eleven Screws, and then tighten them. Do not overtighten the Screws. Make sure that no wires are pinched.**

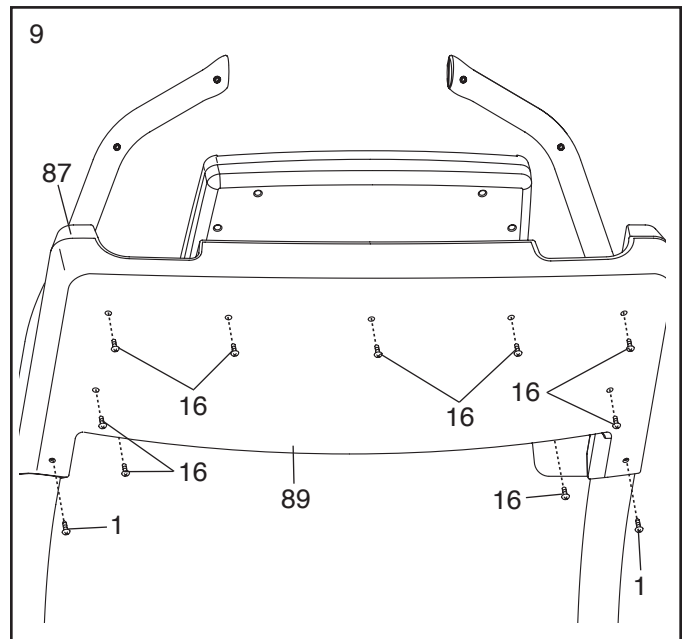

10. See page 14 and plug in the power cord. Next, see page 16 and turn on the power. Then, touch the 1 Step Incline button numbered 40 on the console. The Frame (58) will adjust to an incline of 40 percent. Then, turn off the incline trainer and **unplug the power cord.**

Identify the Left Inside Cover (3) and the Left Outside Cover (106). Next, hold the Left Inside Cover against the left Upright (77). Then, hold the Left Outside Cover against the Left Inside Cover.

Attach the Left Outside Cover (106) to the Left Inside Cover (3) with a #8 x 1 1/4" Screw (36) and two #8 x 3/4" Screws (1). **Start all three Screws and then tighten them.**

**Attach the Right Inside Cover and the Right Outside Cover (not shown) as described above.**

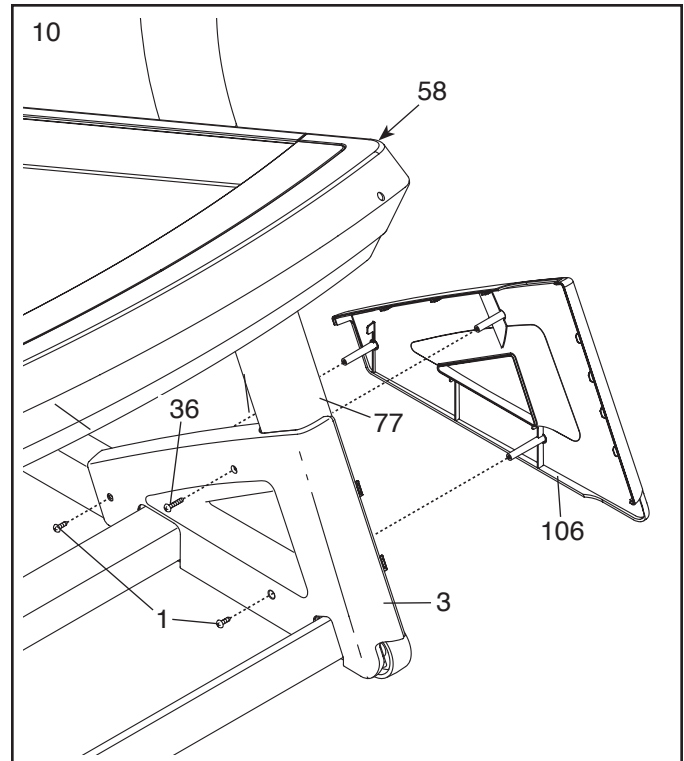

11. If necessary, move the incline trainer to the desired location (see HOW TO MOVE THE INCLINE TRAINER on page 27).

After the incline trainer is placed in the location where it will be used, make sure that the incline trainer rests firmly on the floor. If the incline trainer rocks even slightly, turn the Leveling Feet (110) as needed until the rocking motion is eliminated.

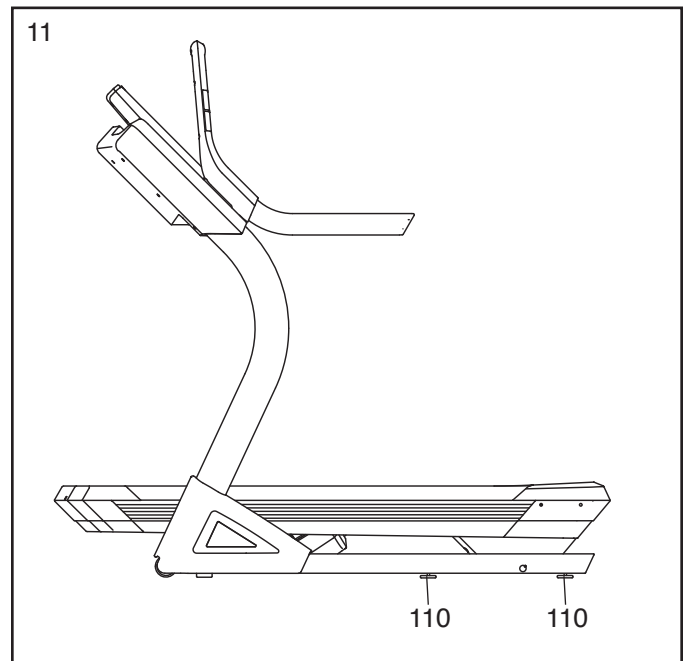

12. **Make sure that all parts are properly tightened before you use the incline trainer.** Keep the included hex keys in a secure place. One of the hex keys is used to adjust the walking belt (see pages 29 and 30). **To protect the floor or carpet from damage, place a mat under the incline trainer.**

# THE CHEST HEART RATE MONITOR

## HOW TO PUT ON THE HEART RATE MONITOR

The heart rate monitor consists of a chest strap and a sensor. Insert the tab on one end of the chest strap into the hole in one end of the sensor as shown. Then, press the end of the sensor under the buckle on the chest strap. The tab should be flush with the front of the sensor.

The heart rate monitor must be worn under your clothes, tight against your skin. Wrap the heart rate monitor around your chest in the location shown. Make sure that the logo is right-side-up. Then, attach the other end of the chest strap to the sensor. Adjust the length of the chest strap, if necessary.

Pull the sensor away from your body a few inches and locate the two electrode areas, which are covered by shallow ridges. Using saline solution such as saliva or contact lens solution, wet the electrode areas. Then, return the sensor to a position against your chest.

## CARE AND MAINTENANCE

- Thoroughly dry the sensor with a soft towel after each use. Moisture may keep the sensor activated, shortening the life of the battery.
- Store the heart rate monitor in a warm, dry place. Do not store the heart rate monitor in a plastic bag or other container that may trap moisture.

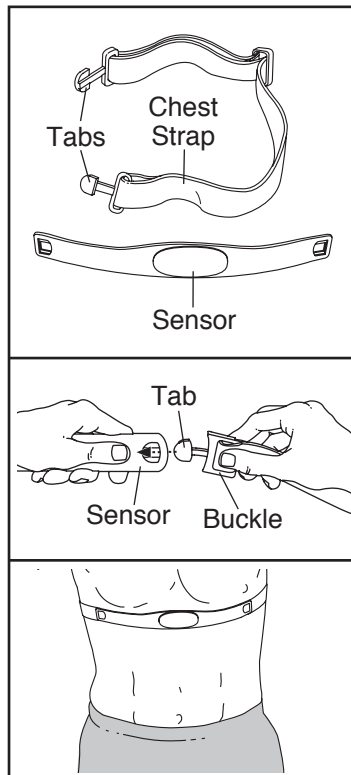

- Do not expose the heart rate monitor to direct sunlight for extended periods of time; do not expose it to temperatures above 122° F (50° C) or below 14° F (-10° C).
- Do not excessively bend or stretch the sensor when using or storing the heart rate monitor.
- To clean the sensor, use a damp cloth and a small amount of mild soap. Then, wipe the sensor with a damp cloth and thoroughly dry it with a soft towel. Never use alcohol, abrasives, or chemicals to clean the sensor. Hand wash and air dry the chest strap.

## TROUBLESHOOTING

If the heart rate monitor does not function properly, try the steps below.

- Make sure that you are wearing the heart rate monitor as described at the left. If the heart rate monitor does not function when positioned as described, move it slightly lower or higher on your chest.
- If heart rate readings are not displayed until you begin perspiring, rewet the electrode areas.
- For the console to display heart rate readings, you must be within arm's length of the console.
- If there is a battery cover on the back of the sensor, replace the battery with a new battery of the same type.
- The heart rate monitor is designed to work with people who have normal heart rhythms. Heart rate reading problems may be caused by medical conditions such as premature ventricular contractions (pvc's), tachycardia bursts, and arrhythmia.
- The operation of the heart rate monitor can be affected by magnetic interference from high power lines or other sources. If you suspect that magnetic interference is causing a problem, try relocating the fitness equipment.

# OPERATION AND ADJUSTMENT

## HOW TO CONNECT THE POWER CORD

### Use a Surge Suppressor

Your treadmill, like other electronic equipment, can be damaged by sudden voltage changes in your home's power. Voltage surges, spikes, and noise interference can result from weather conditions or from other appliances being turned on or off. **To decrease the risk of damaging the treadmill, always use a surge suppressor with the treadmill. To purchase a surge suppressor, see precaution 12 on page 3.**

Use only a surge suppressor that is UL 1449 listed as a transient voltage surge suppressor (TVSS). The surge suppressor must have a UL suppressed voltage rating of 400 volts or less and a minimum surge dissipation of 450 joules. The surge suppressor must also be electrically rated for 120 volts AC and 15 amps. There must be a monitoring light on the surge suppressor to indicate whether it is functioning properly. **Failure to use a properly functioning surge suppressor could result in damage to the control system of the treadmill and serious injury to users.**

### Plug in the Power Cord

**The treadmill must be grounded.** If it should malfunction or break down, grounding provides a path of least resistance for electric current to reduce the risk of electric shock. The treadmill power cord has a plug with a grounding pin (see drawing 1 on this page).

**⚠ DANGER:** Improper connection of the power cord increases the risk of electric shock. Do not modify the plug—if it will not fit an outlet, have a proper outlet installed by a qualified electrician. If you are unsure whether the treadmill is properly grounded, contact a qualified electrician.

Plug the power cord into a surge suppressor, and plug the surge suppressor into an appropriate outlet that is properly installed and grounded in accordance with all local codes and ordinances. **The outlet must be on a**

nominal 120-volt circuit capable of carrying 15 or more amps. To avoid overloading the circuit, do not plug other electrical devices, except for low-power devices such as cell phone chargers, into the surge suppressor or into an outlet on the same circuit. **IMPORTANT: The treadmill is not compatible with GFCI-equipped outlets and may not be compatible with AFCI-equipped outlets.**

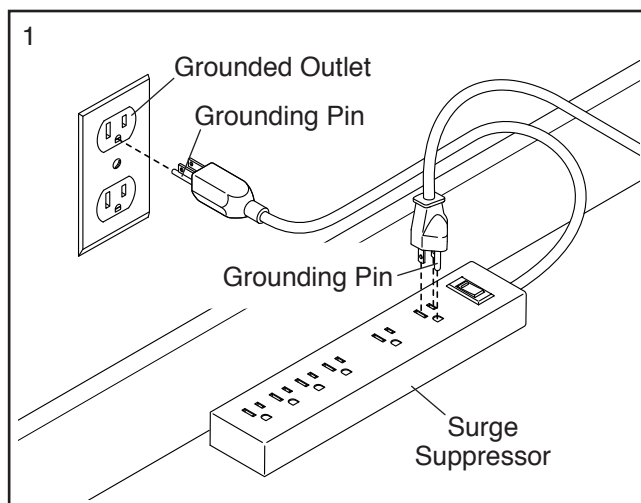

A temporary adapter may be used to connect the surge suppressor to a 2-pole receptacle if a properly grounded outlet is not available.

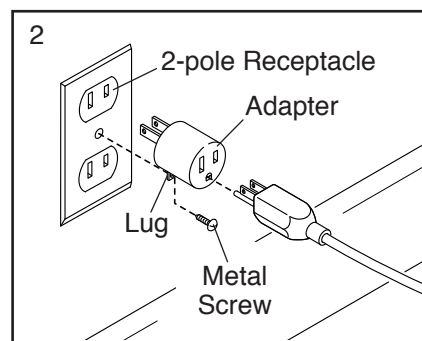

The lug or wire extending from the adapter must be connected with a metal screw to a permanent ground such as a properly grounded outlet box cover. **Some 2-pole receptacle outlet box covers are not grounded. Before using an adapter, contact a qualified electrician to determine whether the outlet box cover is grounded. The temporary adapter should be used only until a properly grounded outlet can be installed by a qualified electrician.**

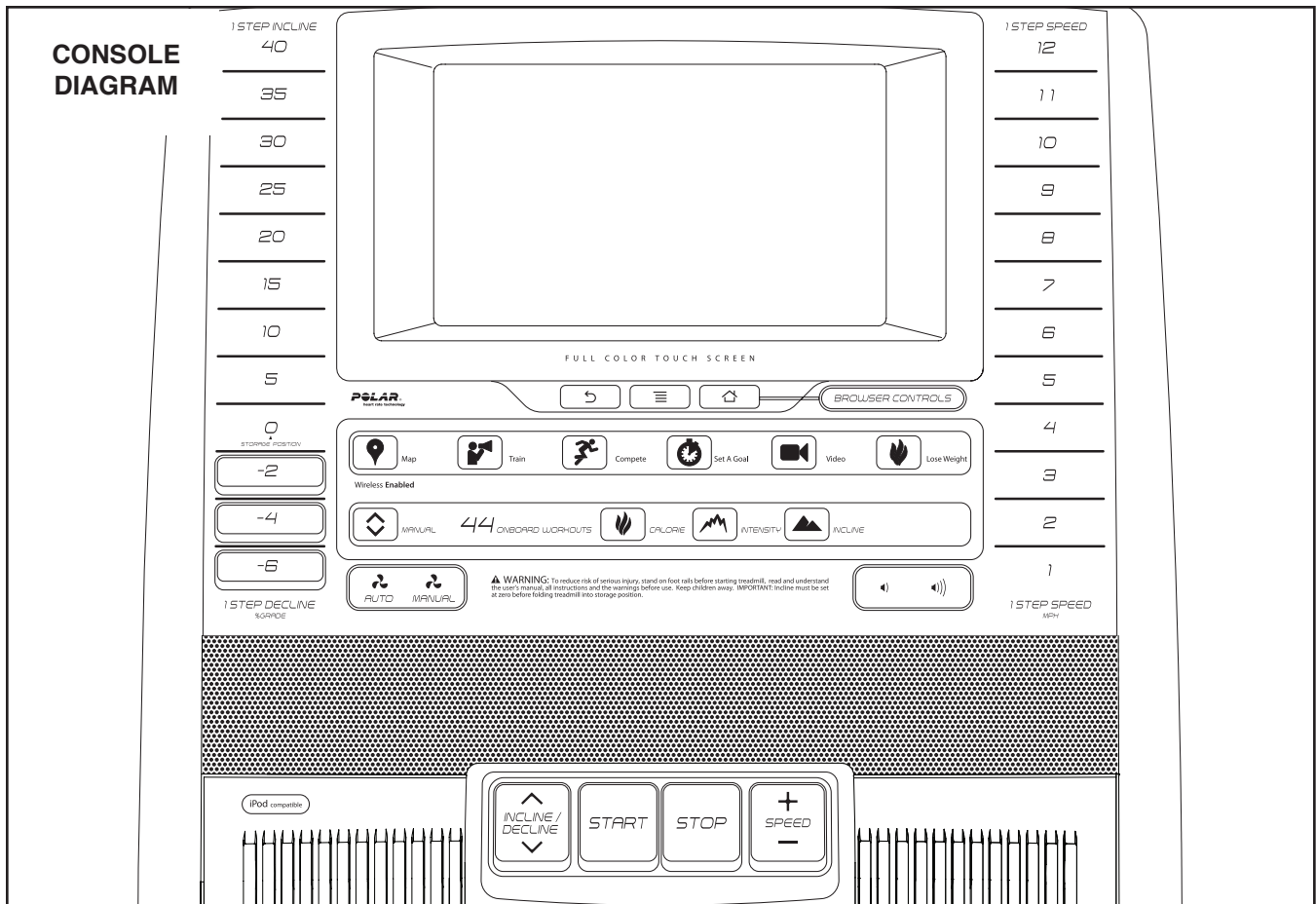

## FEATURES OF THE CONSOLE

The incline trainer console offers an impressive array of features designed to make your workouts more effective and enjoyable. The console features revolutionary iFit Live technology that enables the incline trainer to communicate with your wireless network. With iFit Live technology, you can download personalized workouts, create your own workouts, track your workout results, and access many other features. **See [www.iFit.com](http://www.iFit.com) for complete information.**

In addition, the console features a selection of onboard workouts, including at least eight calorie workouts, eight intensity workouts, eight speed workouts, eight incline workouts, and six iFit Live demo workouts. Each workout automatically controls the speed and incline of the incline trainer as it guides you through an effective exercise session. In addition, you can set a calorie, time, distance, or pace goal.

When you use the manual mode, you can change the speed and incline of the incline trainer with the touch of a button.

As you exercise, the console will display instant exercise feedback. You can also measure your heart rate using the handgrip heart rate monitor or the chest heart rate monitor.

You can even browse the Internet or listen to your favorite workout music or audio books with the console's stereo sound system while you exercise.

**To turn on the power, see page 16. To learn how to use the touch screen, see page 16. To set up the console, see page 17.**

Note: The console can display speed and distance in either miles or kilometers. To find which unit of measurement is selected, see step 4 on page 23. For simplicity, all instructions in this section refer to miles.

## HOW TO TURN ON THE POWER

**IMPORTANT:** If the incline trainer has been exposed to cold temperatures, allow it to warm to room temperature before you turn on the power. If you do not do this, you may damage the console display or other electrical components.

Plug in the power cord (see page 14). Next, locate the power switch on the incline trainer frame near the power cord. Make sure that the switch is in the reset position.

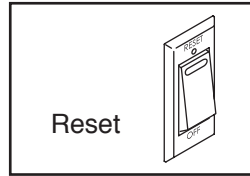

**IMPORTANT:** The console features a display demo mode, designed to be used if the incline trainer is displayed in a store. If the demo mode is turned on, the screen will show a demo presentation after you plug in the power cord and press the power switch into the reset position, before you insert the key. To turn off the demo mode, see step 5 on page 23.

Next, stand on the foot rails of the incline trainer. Locate the clip attached to the key, and slide the clip securely onto the waistband of your clothes. Then, insert the key into the console. **Note:** It may take a minute for the console to be ready for use. **IMPORTANT:** In an emergency, the key can be pulled from the console, causing the walking belt to slow to a stop. Test the clip by carefully taking a few steps backward; if the key is not pulled from the console, adjust the position of the clip.

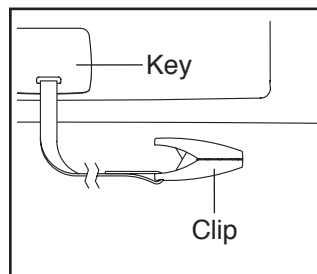

## HOW TO USE THE TOUCH SCREEN

The console features a tablet with a full-color touch screen. The following information will help you become familiar with the tablet's advanced technology:

- The console functions similarly to other tablets. You can slide or flick your finger against the screen to move certain images on the screen, such as the displays in a workout (see step 5 on page 18). However, you cannot zoom in and out by sliding your fingers on the screen.
- The screen is not pressure sensitive. You do not need to press hard on the screen.
- To type information into a text box, touch the text box to view the keyboard. To use numbers or other characters on the keyboard, touch the ?123 button. To view more characters, touch the Alt button. Touch the Alt button again to return to the number keyboard. To return to the letter keyboard, touch the ABC button. To use a capital character, touch the button with an upward-facing arrow. To use multiple capital characters, touch the arrow button again. To return to the lowercase keyboard, touch the arrow button a third time. To clear the last character, touch the button with a backward-facing arrow and an X.
- Use the buttons on the console shown below to navigate the tablet. Press the back button to return to the previous screen. Press the home button to return to the main menu. Note: The center button does not function.

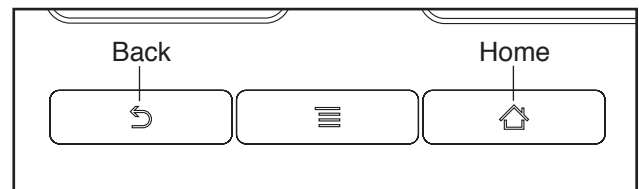



## HOW TO SET UP THE CONSOLE

Before using the incline trainer for the first time, set up the console.

### 1. Connect to your wireless network.

Note: In order to access the Internet, download iFit Live workouts, and use several other features of the console, you must be connected to a wireless network. See HOW TO USE THE WIRELESS NETWORK MODE on page 25 to connect the console to your wireless network.

### 2. Check for firmware updates.

First, see step 1 on page 23 and step 2 on page 24 and select the maintenance mode. Then, see step 3 on page 24 and check for firmware updates.

### 3. Calibrate the incline system.

See step 4 on page 24 and calibrate the incline system of the incline trainer.

### 4. Create an iFit Live account.

Touch the globe button near the lower-left corner of the screen and touch the iFit Live button.

Note: For information about navigating in the browser, see page 26. The browser will open to the iFit.com home page. Touch the Register button in the upper-right corner of the screen.

The browser will open to the iFit.com registration page. Touch an entry box to view the keyboard. Slide your finger up or down the screen to scroll up or down the page.

Next, enter a username and password and your e-mail address. Enter the activation code from the iFit Live flier that came with the incline trainer. Touch the Place of Purchase drop-down menu for a list of options; then, touch the location where you purchased your product. Touch the words MEDICAL DISCLAIMER, read the medical disclaimer, touch the I Accept button, and check the medical disclaimer checkbox. Then, touch the Confirm Activation Code button.

Enter the requested personal information. When you have entered all of the information, touch the Finish button. Then, touch the home button on the console to exit the browser.

The console is now ready for you to begin working out. The following pages explain the various workouts and other features that the console offers.

**To use the manual mode**, see page 18. **To use an onboard workout**, see page 20. **To use a set-a-goal workout**, see page 21. **To use an iFit Live workout**, see page 22.

**To use the equipment settings mode**, see page 23. **To use the maintenance mode**, see page 24. **To use the wireless network mode**, see page 25. **To use the stereo sound system**, see page 26. **To use the Internet browser**, see page 26.

**IMPORTANT: If there are sheets of plastic on the console, remove the plastic. To prevent damage to the walking platform, wear clean athletic shoes while using the incline trainer. The first time you use the incline trainer, observe the alignment of the walking belt, and center the walking belt if necessary (see page 30).**

## HOW TO USE THE MANUAL MODE

### 1. Insert the key into the console.

See HOW TO TURN ON THE POWER on page 16. **Note: It may take a minute for the console to be ready for use.**

### 2. Select the main menu.

When you turn on the power, the main menu will appear after the console boots up. Touch the home button in the lower-left corner of the screen (not shown here) to return to the main menu at any time.

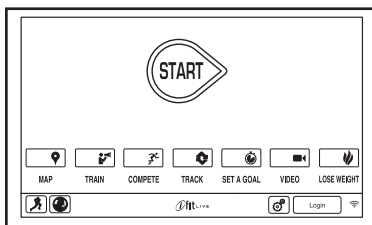

### 3. Start the walking belt and adjust the speed.

Touch the Start button on the screen or press the Start button on the console to start the walking belt. You can also press the Manual button on the console, and then touch the Resume button on the screen. The walking belt will begin to move at 1 mph. As you exercise, change the speed of the walking belt as desired by pressing the Speed increase and decrease buttons. Each time you press one of the buttons, the speed setting will change by 0.1 mph; if you hold down the button, the speed setting will change in increments of 0.5 mph.

If you press one of the numbered 1 Step Speed buttons, the walking belt will gradually change speed until it reaches the selected speed setting.

To stop the walking belt, press the Stop button. To restart the walking belt, press the Start button.

### 4. Change the incline of the incline trainer as desired.

To change the incline of the incline trainer, press the Incline/Decline buttons or one of the numbered 1 Step Incline/Decline buttons. Each time you press one of the buttons, the incline will gradually change until it reaches the selected incline setting.

**Note:** For your safety, as you adjust the incline setting to negative levels or to levels above 15%, the maximum speed of the incline trainer will decrease at set intervals.

**Note:** The first time you adjust the incline, you must first calibrate the incline system (see step 4 on page 24).

### 5. Monitor your progress.

The console offers several display modes. The display mode that you select will determine which workout information is shown. To select the desired display mode, simply flick or slide the screen. You can also view additional information by touching the red boxes on the screen.

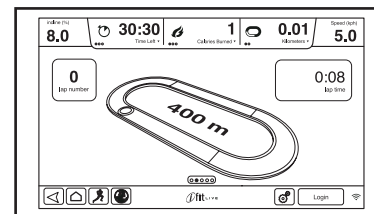

As you walk or run on the incline trainer, the screen can show the following workout information:

- The incline level of the incline trainer
- The time elapsed
- The time left (**Note:** The manual mode does not have a time left countdown.)
- The approximate number of calories you have burned
- The approximate number of calories you are burning per hour
- The distance that you have walked or run
- The number of vertical feet you have climbed
- The speed of the walking belt
- A track representing 1/4 mile (400 m)
- Your pace in minutes per mile
- Your current lap number
- Your heart rate (see step 6)

The displays at the top of the screen can show two types of information. Touch each display until the display shows the desired information.

If desired, adjust the volume by pressing the volume increase and decrease buttons on the console.

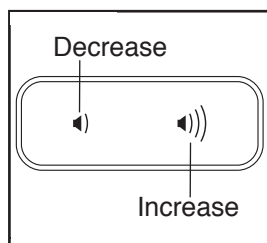

To pause the workout, touch one of the menu buttons or press the Stop button on the console. To continue the workout, touch the Resume button or the Start button. To end the workout session, touch the End Workout button.

#### 6. Measure your heart rate if desired.

**Note: If you use the handgrip heart rate monitor and the chest heart rate monitor at the same time, the console will not display your heart rate accurately.** For information about the chest heart rate monitor, see page 13.

Before using the handgrip heart rate monitor, remove the sheets of plastic from the metal contacts. In addition, make sure that your hands are clean.

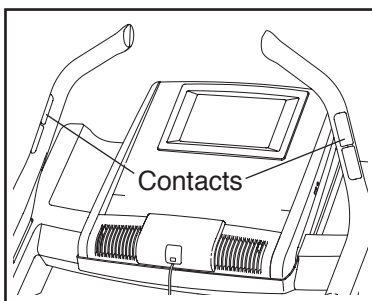

To measure your heart rate, **stand on the foot rails** and hold the contacts with your palms for approximately ten seconds; **avoid moving your hands**. When your pulse is detected, your heart

rate will be shown. **For the most accurate heart rate reading, continue to hold the contacts for about 15 seconds.**

#### 7. Turn on the fan if desired.

The fan features several speed settings and an auto mode. When the auto mode is selected, the speed of the fan will automatically increase and decrease as the speed of the walking belt increases and decreases.

Press the Manual fan button repeatedly to select a fan speed or to turn off the fan. Press the Auto fan button to select the auto mode or to turn off the fan.



#### 8. When you are finished exercising, remove the key from the console.

Step onto the walking platform and touch the home button or the back button on the screen or press the Stop button on the console. A workout summary will appear on the screen. After you view the workout summary, touch the Finish button to return to the main menu. You may also be able to either save or publish your results using one of the options on the screen. Then, remove the key from the console and put it in a secure place.

When you are finished using the incline trainer, press the power switch into the off position and unplug the power cord. **IMPORTANT: If you do not do this, the incline trainer's electrical components may wear prematurely.**

## HOW TO USE AN ONBOARD WORKOUT

### 1. Insert the key into the console.

See HOW TO TURN ON THE POWER on page 16.

### 2. Select an onboard workout.

To select an onboard workout, press the Calorie button, the Intensity button, or the Incline button on the console. Note: You can also touch the runner icon on the screen to select the Workouts menu.

Then, select the desired workout. The screen will show the name, duration, and distance of the workout. The screen will also show the approximate number of calories you will burn during the workout and a profile of the incline settings of the workout.

### 3. Start the workout.

Touch the Start Workout button to start the workout. A moment after you touch the button, the walking belt will begin to move. Hold the handrails and begin walking.

Each workout is divided into several segments. One speed setting and one incline setting are programmed for each segment. Note: The same speed setting and/or incline setting may be programmed for consecutive segments.

During the workout, the profile will show your progress. To view the profile, flick or slide the screen. The vertical colored line will indicate the current segment of the workout. The bottom profile represents the incline setting of the current segment. The top profile represents the speed setting of the current segment.

At the end of the first segment of the workout, the incline trainer will automatically adjust to the speed and/or incline settings for the next segment.

The workout will continue in this way until the last segment ends. The walking belt will then slow to a stop and a workout summary will appear on the screen. After you view the workout summary, touch the Finish button to return to the main menu. You may also be able to either save or publish your results using one of the options on the screen.

If the speed or incline setting is too high or too low at any time during the workout, you can override the setting by pressing the Speed or Incline buttons; **however, when the next segment begins, the incline trainer will automatically adjust to the speed and incline settings for the next segment.**

To pause the workout, touch either the back button or the home button in the lower-left corner of the screen, or press the Stop button on the console. To continue the workout, touch the Resume button or press the Start button on the console. To end the workout, touch the End Workout button.

**Note: The calorie goal is an estimate of the number of calories that you will burn during the workout. The actual number of calories that you burn will depend on your metabolic rate. In addition, if you manually change the speed or incline of the incline trainer during the workout, the number of calories you burn will be affected.**

### 4. Monitor your progress.

See step 5 on page 18. The screen can also show a profile of the speed and incline settings of the workout.

### 5. Measure your heart rate if desired.

See step 6 on page 19.

### 6. Turn on the fan if desired.

See step 7 on page 19.

### 7. When you are finished exercising, remove the key from the console.

See step 8 on page 19.

## HOW TO USE A SET-A-GOAL WORKOUT

### 1. Insert the key into the console.

See HOW TO TURN ON THE POWER on page 16.

### 2. Select the main menu.

See step 2 on page 18.

### 3. Select a set-a-goal workout.

To select a set-a-goal workout, touch the Set A Goal button on the screen or press the Set A Goal button on the console.

To set a calorie, time, distance, or pace goal, touch the Calories, Time, Distance, or Pace button.

Then, touch the increase

and decrease buttons on the screen to select a calorie, time, distance, or pace goal and to select the speed and incline for the workout. The screen will show the duration and distance of the workout, and the approximate number of calories you will burn during the workout.

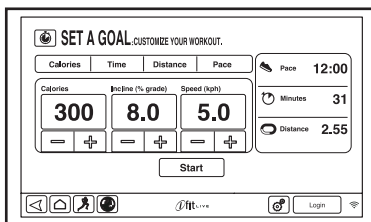

### 4. Start the workout.

Touch the Start button to start the workout. A moment after you touch the button, the walking belt will begin to move. Hold the handrails and begin walking.

The workout will function in the same way as the manual mode (see pages 18 and 19).

The workout will continue until you reach the goal that you set. The walking belt will then slow to a stop, and a workout summary will appear on the screen. After you view the workout summary, touch the Finish button to return to the main menu. You may also be able to either save or publish your results using one of the options on the screen.

**Note: The calorie goal is an estimate of the number of calories that you will burn during the workout. The actual number of calories that you burn will depend on your metabolic rate.**

### 5. Monitor your progress.

See step 5 on page 18.

### 6. Measure your heart rate if desired.

See step 6 on page 19.

### 7. Turn on the fan if desired.

See step 7 on page 19.

### 8. When you are finished exercising, remove the key from the console.

See step 8 on page 19.

## HOW TO USE AN iFIT LIVE WORKOUT

Note: To use an iFit Live workout, you must have access to a wireless network (see HOW TO USE THE WIRELESS NETWORK MODE on page 25). An iFit Live account is also required.

### 1. Insert the key into the console.

See HOW TO TURN ON THE POWER on page 16.

### 2. Select the main menu.

See step 2 on page 18.

### 3. Log in to your iFit Live account.

If you have not already done so, touch the Login button to log in to your iFit Live account. The screen will ask for your iFit.com username and password. Enter them and touch the Submit button. Touch the Cancel button to exit the login screen.

### 4. Select an iFit Live workout.

To download an iFit Live workout in your schedule, touch the Map, Train, Video, or Lose Weight button to download

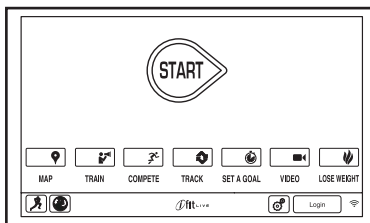

the next workout of that type in your schedule.

Note: You may be able to access demo workouts through these options, even if you do not log in to an iFit Live account.

To compete in a race that you have previously scheduled, touch the Compete button. To view your Workout History, touch the Track button. To use a set-a-goal workout, touch the Set A Goal button (see page 21). Note: You can also press one of the iFit Live buttons on the console.

To switch users within the account, touch the user button near the lower right corner of the screen.

Before some workouts will download, you must add them to your schedule on iFit.com.

**For more information about the iFit Live workouts, please see [www.iFit.com](http://www.iFit.com).**

When you select an iFit Live workout, the screen will show the name, duration, and distance of the workout. The screen will also show the approximate number of calories you will burn during the workout. If you select a competition workout, the display will count down to the beginning of the race.

### 5. Start the workout.

See step 3 on page 20.

During some workouts, the voice of a personal trainer will guide you through your workout.

### 6. Monitor your progress.

See step 5 on page 18. The screen may also show a map of the trail you are walking or running.

During a competition workout, the screen will show the speeds of the runners and the distances they have run. The screen will also show the numbers of seconds that the other runners are ahead of you or behind you.

### 7. Measure your heart rate if desired.

See step 6 on page 19.

### 8. Turn on the fan if desired.

See step 7 on page 19.

### 9. When you are finished exercising, remove the key from the console.

See step 8 on page 19.

**For more information about the iFit Live mode, go to [www.iFit.com](http://www.iFit.com).**

## HOW TO USE THE EQUIPMENT SETTINGS MODE

The console features an equipment settings mode that allows you to select a language and the unit of measurement, to turn on and turn off the display demo mode, and to enable or disable the key.

### 1. Select the settings main menu.

Insert the key into the console (see HOW TO TURN ON THE POWER on page 16). Next, select the main menu (see step 2 on page 18). Then, touch the gears button near the lower right corner of the screen to select the settings main menu.

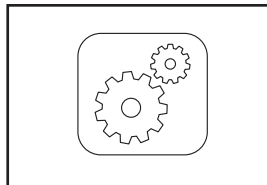

### 2. Select the equipment settings mode.

In the settings main menu, touch the Equipment Settings button.

### 3. Select a language.

To select a language, touch the Language button and select the desired language. Then, touch the back button on the screen to return to the equipment settings mode. Note: This feature may not be enabled.

### 4. Select the unit of measurement.

Touch the US/Metric button to view the selected unit of measurement. Change the unit of measurement, if desired. Then, touch the back button on the screen.

### 5. Turn on or turn off the display demo mode.

The console features a display demo mode, designed to be used if the incline trainer is displayed in a store. While the demo mode is turned on, the console will function normally when you plug in the power cord, press the power switch into the

reset position, and insert the key into the console. However, when you remove the key, the screen will show a demo presentation.

To turn on or turn off the display demo mode, first touch the Demo Mode button. Next, touch the On checkbox or the Off checkbox. Then, touch the back button on the screen.

### 6. Enable or disable the key.

Note: This feature may not be enabled on your incline trainer.

You can disable the key so that the incline trainer does not require the use of the key if desired. Touch the Safety Key button. To disable the key, touch the Disable checkbox. **CAUTION: Read the safety warning on the screen before disabling the key.** To enable the key again, touch the Enable checkbox.

### 7. Enable or disable a passcode.

The console features a child safety passcode, designed to prevent unauthorized users from using the incline trainer.

Touch the Passcode button. To enable a passcode, touch the Enable checkbox. Then, enter a 4-digit passcode of your choice. Touch Save to use this passcode. Touch Cancel to return to the equipment settings mode and not use a passcode. To disable the passcode, touch the Disable checkbox.

Note: If a passcode is enabled, the console will regularly ask for you to enter the passcode. The console will remain locked until the correct passcode is entered. **IMPORTANT: If you forget your passcode, enter the following master passcode to unlock the console: 1985.**

### 8. Exit the equipment settings mode.

To exit the equipment settings mode, touch the back button on the screen.

## HOW TO USE THE MAINTENANCE MODE

The console features a maintenance mode that allows you to update the console firmware, calibrate the incline of the incline trainer, calibrate the screen, view technical information, and view a button's keycode.

### 1. Select the settings main menu.

See step 1 on page 23.

### 2. Select the maintenance mode.

In the settings main menu, touch the Maintenance button to enter the maintenance mode.

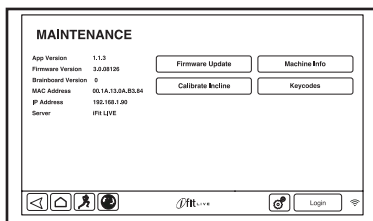

The maintenance mode main screen will show information about the model and version of the incline trainer.

### 3. Update the console firmware.

**For the best results, regularly check for firmware updates.**

Touch the Firmware Update button to check for firmware updates using your wireless network. The update will begin automatically.

**To avoid damaging the incline trainer, do not turn off the power or remove the key while the firmware is being updated.**

Note: Occasionally, a firmware update may cause your console to function slightly differently. These updates are always designed to improve your exercise experience.

Note: If you cannot update the console firmware over your wireless network, you can update the firmware using a USB drive. Go to [www.iFit.com](http://www.iFit.com) and download the latest firmware update onto your

USB drive. Safely remove the USB drive from your computer and plug it into the USB port on the side of the console. The update should begin automatically.

The screen will show the progress of the update. When the update is complete, the incline trainer will turn off and then turn back on. If it does not, press the power switch into the off position. Wait for several seconds, and then press the power switch into the reset position. Note: It may take a few minutes for the console to be ready for use.

### 4. Calibrate the incline system of the incline trainer.

Touch the Calibrate Incline button. Then, touch the Begin button to calibrate the incline system. The incline trainer will automatically rise to the maximum incline level, lower to the minimum incline level, and then return to the starting position. This will calibrate the incline system. Press the Cancel button to return to the maintenance mode. When the incline system is calibrated, touch the Finish button.

**IMPORTANT: Keep pets, feet, and other objects away from the incline trainer while the incline system is calibrating. In an emergency, pull the key from the console to stop the incline calibration.**

### 5. View machine information.

Touch the Machine Info button to view information about your incline trainer. After you view the information, touch the back button on the screen.

### 6. Find keycodes.

The Keycodes button is intended to be used by service technicians to identify whether a certain button is working correctly.

### 7. Exit the maintenance mode.

To exit the maintenance mode, press the back button on the console.



## HOW TO USE THE WIRELESS NETWORK MODE

The console features a wireless network mode that allows you to set up a wireless network connection.

### 1. Select the settings main menu.

See step 1 on page 23.

### 2. Select the wireless network mode.

In the settings main menu, touch the Wireless Network button to enter the wireless network mode.

### 3. Enable Wi-Fi.

Make sure that the Wi-Fi checkbox is marked with a green checkmark. If it is not, touch the Wi-Fi menu option once and wait for a few seconds. The console will search for available wireless networks.

### 4. Set up and manage a wireless network connection.

When Wi-Fi is enabled, the screen will show a list of available networks. Note: It may take several seconds for the list of wireless networks to appear.

Make sure that the checkbox on the Network notification menu option is marked with a green checkmark to have the console notify you when a wireless network is within range and available.

Note: You must have your own wireless network and an 802.11b/n router with SSID broadcast enabled (hidden networks are not supported).

When a list of networks appears, touch the desired network. Note: You will need to know your network name (SSID). If your network has a password, you will also need to know the password.

An information box will ask if you want to connect to the wireless network. Touch the Connect button to connect to the network or touch the Cancel button to return to the list of networks. If the network has a password, touch the password entry box. A keyboard will appear on the screen. To view the password as you type it, touch the Show Password checkbox.

To use the keyboard, see HOW TO USE THE TOUCH SCREEN on page 16.

When the console is connected to your wireless network, the WiFi menu option at the top of the screen will display the word CONNECTED. Then, press the back button on the console to return to the wireless network mode.

To disconnect from a wireless network, select the wireless network and then touch the Forget button.

If you are having problems connecting to an encrypted network, make sure that your password is correct. Note: Passwords are case-sensitive.

Note: The iFit Live mode supports unsecured and secured (WEP, WPA, and WPA2) encryption. A broadband connection is recommended; performance depends on connection speed.

**Note: If you have questions after following these instructions, go to [www.iFit.com/support](http://www.iFit.com/support) for assistance.**

### 5. Exit the wireless network mode.

To exit the wireless network mode, press the back button on the console.

## HOW TO USE THE STEREO SOUND SYSTEM

To play music or audio books through the console's speakers, you must connect your MP3 player, CD player, or other personal audio player to the console.

Plug one end of your audio wire into the audio jack on the side of the console. Plug the other end into a jack on your MP3 player, CD player, or other personal audio player. **Make sure that the audio wire is fully plugged in.**

Next, press the play button on your MP3 player, CD player, or other personal audio player. Then, adjust the volume level on your personal audio player or press the volume increase and decrease buttons on the console.

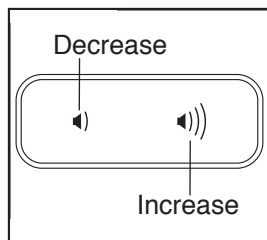

If you are using a personal CD player and the CD skips, set the CD player on the floor or another flat surface instead of on the console.

Note: The USB port on the side of the console is for firmware updates only.

## HOW TO USE THE INTERNET BROWSER

Note: To use the browser, you must have access to a wireless network including an 802.11b/n router with SSID broadcast enabled (hidden networks are not supported).

To open the browser, touch the globe button near the lower left corner of the screen. Then, select a website.

To return to the previous web page, press the back button on the console or touch the Browser Back button on the screen. To exit the browser, press the home button on the console or touch the Return button on the screen.

To use the keyboard, see HOW TO USE THE TOUCH SCREEN on page 16.

To enter a different web address in the URL bar, first, slide your finger down the screen to view the URL bar, if necessary. Then, touch the URL bar, use the keyboard to enter the address, and touch the Go button.

Note: While you are using the browser, the speed, incline, fan, and volume buttons will still function, but the workout buttons will not function.

**Note: If you have questions after following these instructions, go to [www.iFit.com/support](http://www.iFit.com/support) for assistance.**

# HOW TO MOVE THE INCLINE TRAINER

Before moving the incline trainer, insert the key into the console, raise the incline to the maximum incline level, remove the key, and unplug the power cord.

Due to the size and weight of the incline trainer, moving it requires two or three persons. Hold the uprights firmly near the console. Tip the incline trainer back until it rolls freely on the wheels. **CAUTION: To decrease the possibility of injury or of damage to the incline trainer, do not lift the incline trainer by the plastic belly pan. Do not pull on the console.**

Carefully roll the incline trainer on the wheels to the desired location, and then lower it to the level position. **CAUTION: To reduce the risk of injury, use extreme caution while moving the incline trainer. Do not attempt to move the incline trainer over uneven surfaces.**

Make sure that the incline trainer rests firmly on the floor. If the incline trainer rocks even slightly, turn the Leveling Feet (110) as needed until the rocking motion is eliminated.

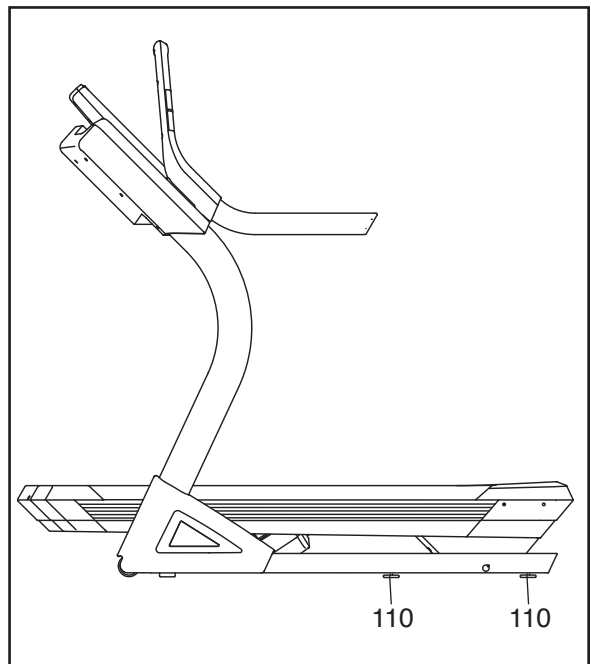
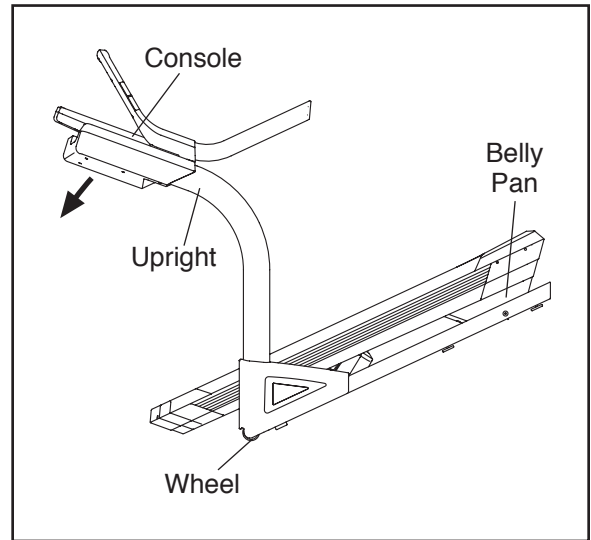

# TROUBLESHOOTING

Most incline trainer problems can be solved by following the simple steps below. Find the symptom that applies, and follow the steps listed. If further assistance is needed, see the front cover of this manual.

## SYMPTOM: The power does not turn on

- Make sure that the power cord is plugged into a surge suppressor, and that the surge suppressor is plugged into a properly grounded outlet (see page 14). Use only a surge suppressor that meets all of the specifications described on page 14.  
**IMPORTANT: The incline trainer is not compatible with GFCI-equipped outlets and may not be compatible with AFCI-equipped outlets.**
- After the power cord has been plugged in, make sure that the key is inserted into the console.
- Check the power switch located on the incline trainer frame near the power cord. If the switch protrudes as shown, the switch has tripped. To reset the power switch, wait for five minutes and then press the switch back in.

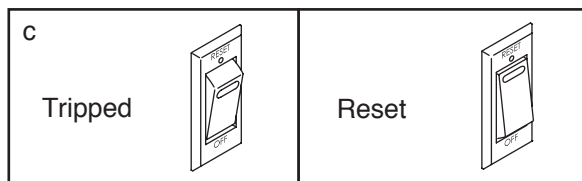

## SYMPTOM: The power turns off during use

- Check the power switch (see the drawing above). If the switch has tripped, wait for five minutes and then press the switch back in.
- Make sure that the power cord is plugged in. If the power cord is plugged in, unplug it, wait for five minutes, and then plug it back in.

- Remove the key from the console, and then reinsert it.
- If the incline trainer still will not run, please see the front cover of this manual.

## SYMPTOM: The console displays remain lit when you remove the key from the console

- The console features a display demo mode, designed to be used if the incline trainer is displayed in a store. If the screen remains lit when you remove the key, the demo mode is turned on. To turn off the demo mode, see step 5 on page 23.

## SYMPTOM: The console does not display speed and distance correctly

- Remove the key from the console and **UNPLUG THE POWER CORD**. Next, remove the three indicated #8 x 1/2" Cover Screws (18) and the #8 x 1 1/4" Screw (36). Lift off the Left Roller Cover (38).

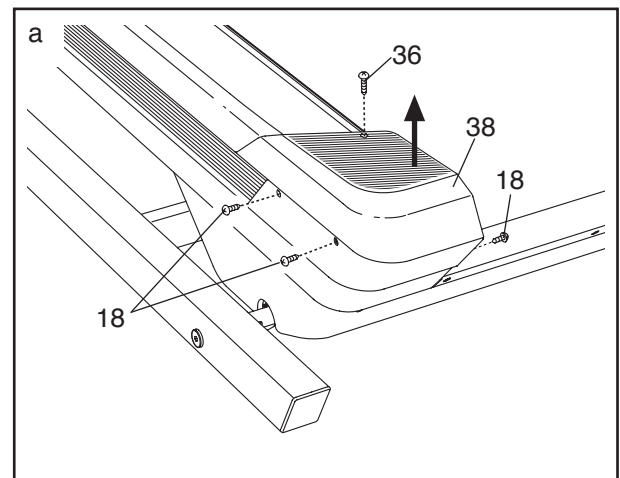

Locate the Reed Switch (55) and the Magnet (41) on the left side of the Pulley (42). Turn the Pulley until the Magnet is aligned with the Reed Switch. **Make sure that the gap between the Magnet and the Reed Switch is about 1/8 in. (3 mm).** If necessary, loosen the #8 x 3/4" Clamp Screw (20), move the Reed Switch slightly, and then retighten the Screw. Reattach the Left Roller Cover (not shown) and run the incline trainer for a few minutes to check for a correct speed reading.

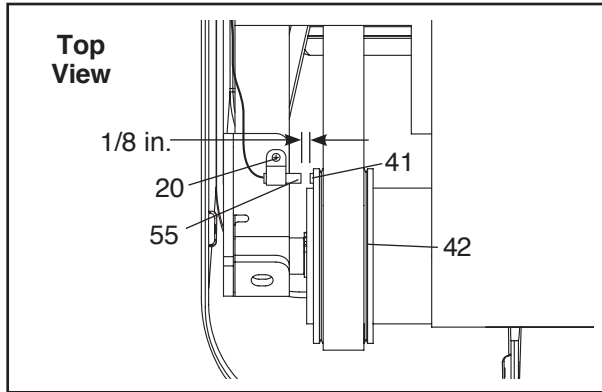

**SYMPTOM: The incline of the incline trainer does not change correctly**

- a. Calibrate the incline system (see step 4 on page 24).

**SYMPTOM: The walking belt slows when walked on**

- a. Use only a surge suppressor that meets all of the specifications described on page 14.

- b. If the walking belt is overtightened, incline trainer performance may decrease and the walking belt may become damaged. First, adjust the incline to 40 percent. Then, remove the key and **UNPLUG THE POWER CORD**. Using the hex key, turn both idler roller screws counterclockwise, 1/4 of a turn. When the walking belt is properly tightened, you should be able to lift each edge of the walking belt 3 to 4 in. (8 to 10 cm) off the walking platform. Be careful to keep the walking belt centered. Then, plug in the power cord, insert the key, and run the incline trainer for a few minutes. Repeat until the walking belt is properly tightened.

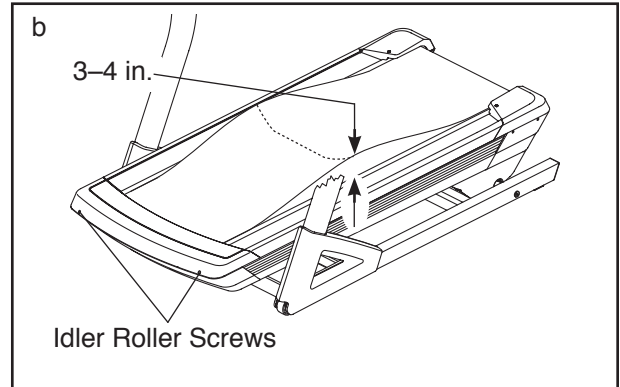

- c. Your incline trainer features a walking belt coated with high-performance lubricant. **IMPORTANT: Never apply silicone spray or other substances to the walking belt or the walking platform unless instructed to do so by an authorized service representative. Such substances may deteriorate the walking belt and cause excessive wear.** If you suspect that the walking belt needs more lubricant, see the front cover of this manual.
- d. If the walking belt still slows when walked on, see the front cover of this manual.

**SYMPTOM: The walking belt is off-center or slips when walked on**

- a. **If the walking belt is off-center**, first adjust the incline to 40 percent. Remove the key and **UNPLUG THE POWER CORD**. **If the walking belt has shifted to the left**, use the hex key to turn the left idler roller screw clockwise 1/2 of a turn; **if the walking belt has shifted to the right**, turn the left idler roller screw counterclockwise 1/2 of a turn. Be careful not to overtighten the walking belt. Then, plug in the power cord, insert the key, and run the incline trainer for a few minutes. Repeat until the walking belt is centered.

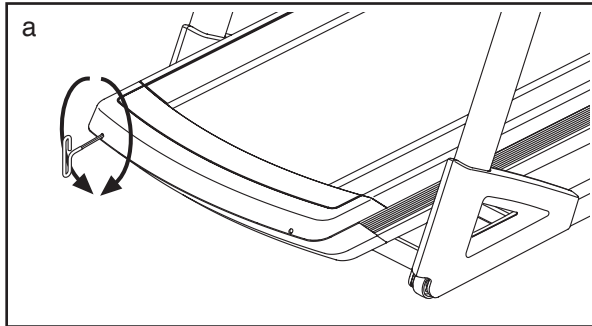

- b. **If the walking belt slips when walked on**, first adjust the incline to 40 percent. Remove the key and **UNPLUG THE POWER CORD**. Using the hex key, turn both idler roller screws clockwise, 1/4 of a turn. When the walking belt is correctly tightened, you should be able to lift each edge of the walking belt 3 to 4 in. (8 to 10 cm) off the walking platform. Be careful to keep the walking belt centered. Then, plug in the power cord, insert the key, and carefully walk on the incline trainer for a few minutes. Repeat until the walking belt is properly tightened.

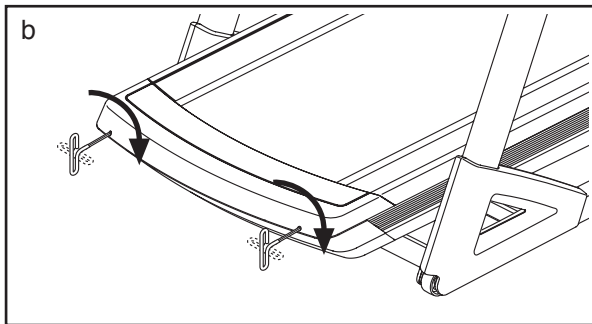

**SYMPTOM: The iFit Live mode does not function correctly**

- a. If the iFit Live mode is not functioning correctly, make sure that the incline trainer has the most current firmware available (see step 3 on page 24).

**SYMPTOM: The incline trainer will not connect to the wireless network**

- a. Make sure that the wireless settings on your console are correct (see step 4 on page 25).
- b. Make sure that the settings for your wireless network are correct.
- c. If you still have questions, see the front cover of this manual.

# EXERCISE GUIDELINES

**⚠ WARNING:** Before beginning this or any exercise program, consult your physician. This is especially important for persons over age 35 or persons with pre-existing health problems.

The heart rate monitor is not a medical device. Various factors may affect the accuracy of heart rate readings. The heart rate monitor is intended only as an exercise aid in determining heart rate trends in general.

These guidelines will help you to plan your exercise program. For detailed exercise information, obtain a reputable book or consult your physician. Remember, proper nutrition and adequate rest are essential for successful results.

## EXERCISE INTENSITY

Whether your goal is to burn fat or to strengthen your cardiovascular system, exercising at the proper intensity is the key to achieving results. You can use your heart rate as a guide to find the proper intensity level. The chart below shows recommended heart rates for fat burning and aerobic exercise.

165	155	145	140	130	125	115	♥
145	138	130	125	118	110	103	♥
125	120	115	110	105	95	90	♥
<hr/>							
20	30	40	50	60	70	80	

To find the proper intensity level, find your age at the bottom of the chart (ages are rounded off to the nearest ten years). The three numbers listed above your age define your "training zone." The lowest number is the heart rate for fat burning, the middle number is the heart rate for maximum fat burning, and the highest number is the heart rate for aerobic exercise.

**Burning Fat**—To burn fat effectively, you must exercise at a low intensity level for a sustained period of time. During the first few minutes of exercise, your body uses carbohydrate calories for energy. Only after the first few minutes of exercise does your body begin to use stored fat calories for energy. If your goal is to burn fat, adjust the intensity of your exercise until your heart rate is near the lowest number in your training zone. For maximum fat burning, exercise with your heart rate near the middle number in your training zone.

**Aerobic Exercise**—If your goal is to strengthen your cardiovascular system, you must perform aerobic exercise, which is activity that requires large amounts of oxygen for prolonged periods of time. For aerobic exercise, adjust the intensity of your exercise until your heart rate is near the highest number in your training zone.

## WORKOUT GUIDELINES

**Warming Up**—Start with 5 to 10 minutes of stretching and light exercise. A warm-up increases your body temperature, heart rate, and circulation in preparation for exercise.

**Training Zone Exercise**—Exercise for 20 to 30 minutes with your heart rate in your training zone. (During the first few weeks of your exercise program, do not keep your heart rate in your training zone for longer than 20 minutes.) Breathe regularly and deeply as you exercise—never hold your breath.

**Cooling Down**—Finish with 5 to 10 minutes of stretching. Stretching increases the flexibility of your muscles and helps to prevent post-exercise problems.

## EXERCISE FREQUENCY

To maintain or improve your condition, complete three workouts each week, with at least one day of rest between workouts. After a few months of regular exercise, you may complete up to five workouts each week, if desired. Remember, the key to success is to make exercise a regular and enjoyable part of your everyday life.

## SUGGESTED STRETCHES

The correct form for several basic stretches is shown at the right. Move slowly as you stretch—never bounce.

### 1. Toe Touch Stretch

Stand with your knees bent slightly and slowly bend forward from your hips. Allow your back and shoulders to relax as you reach down toward your toes as far as possible. Hold for 15 counts, then relax. Repeat 3 times. Stretches: Hamstrings, back of knees and back.

### 2. Hamstring Stretch

Sit with one leg extended. Bring the sole of the opposite foot toward you and rest it against the inner thigh of your extended leg. Reach toward your toes as far as possible. Hold for 15 counts, then relax. Repeat 3 times for each leg. Stretches: Hamstrings, lower back and groin.

### 3. Calf/Achilles Stretch

With one leg in front of the other, reach forward and place your hands against a wall. Keep your back leg straight and your back foot flat on the floor. Bend your front leg, lean forward and move your hips toward the wall. Hold for 15 counts, then relax. Repeat 3 times for each leg. To cause further stretching of the achilles tendons, bend your back leg as well. Stretches: Calves, achilles tendons and ankles.

### 4. Quadriceps Stretch

With one hand against a wall for balance, reach back and grasp one foot with your other hand. Bring your heel as close to your buttocks as possible. Hold for 15 counts, then relax. Repeat 3 times for each leg. Stretches: Quadriceps and hip muscles.

### 5. Inner Thigh Stretch

Sit with the soles of your feet together and your knees outward. Pull your feet toward your groin area as far as possible. Hold for 15 counts, then relax. Repeat 3 times. Stretches: Quadriceps and hip muscles.

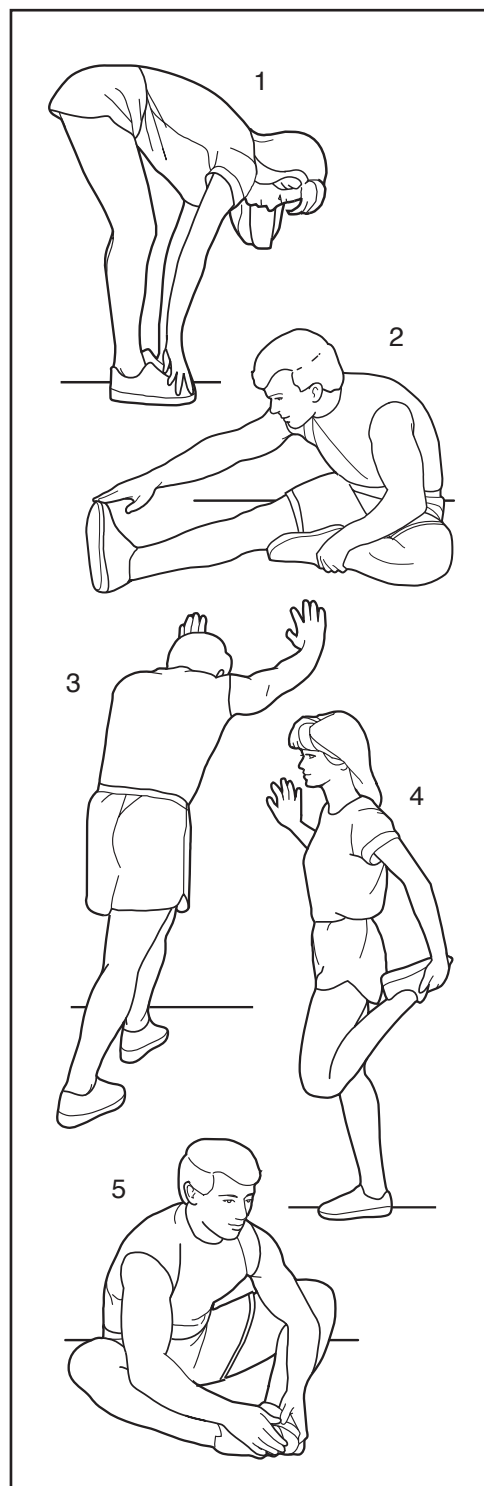



# PART LIST

Model No. NTL19010.2 R0212A

Key No.	Qty.	Description	Key No.	Qty.	Description
1	59	#8 x 3/4" Screw	51	1	Grommet
2	4	#8 x 3/4" Tek Screw	52	1	Belly Pan Cover
3	1	Left Inside Cover	53	1	Power Switch
4	4	5/16" x 2 1/2" Screw	54	1	Belly Pan
5	8	3/8" x 5 1/2" Screw	55	1	Reed Switch
6	2	3/8" Wheel Bolt	56	1	Reed Switch Clamp
7	4	5/16" Flat Washer	57	2	Axle
8	12	3/8" Star Washer	58	1	Frame
9	4	5/16" Star Washer	59	1	Electronics Cover
10	2	Base Foot	60	2	Incline Motor Spacer
11	4	5/16" x 5/8" Screw	61	1	Front Belly Pan
12	2	Wheel	62	1	Left Side Deckrail
13	12	#8 x 1/2" Screw	63	1	Top Incline Motor Cover
14	1	3/16" Hex Key	64	1	Incline Motor
15	1	7/32" Hex Key	65	1	Bottom Incline Motor Cover
16	9	#8 x 3/4" Machine Screw	66	1	Right Side Deckrail
17	2	3/8" x 2 3/4" Screw	67	2	Wire Clamp
18	6	#8 x 1/2" Cover Screw	68	1	Left Foot Rail
19	1	Key/Clip	69	1	Resistor
20	1	#8 x 3/4" Clamp Screw	70	1	Electronics Plate
21	4	#8 Belt Guide Screw	71	1	Controller
22	2	1/4" x 1 1/2" Screw	72	1	Right Foot Rail
23	4	5/16" x 1 3/4" Bolt	73	4	Cushion Cap
24	2	1/4" x 1/2" Screw	74	2	Cushion Spring
25	2	1/4" x 2 1/2" Screw	75	1	Drive Motor
26	4	Rubber Spacer	76	1	Console Frame
27	2	3/8" x 1 3/4" Bolt	77	2	Upright
28	8	#8 x 5/8" Screw	78	1	Upright Wire
29	2	5/16" Motor Screw	79	2	Cushion
30	3	#8 Star Washer	80	1	Base
31	2	1/4" Star Washer	81	3	Round Grommet
32	4	3/8" Jam Nut	82	2	Caution Decal
33	4	5/16" Nut	83	1	Warning Decal
34	2	#8 x 1" Screw	84	2	Base Cap
35	19	Clip	85	2	#8 x 3/4" Pan Head Tek Screw
36	4	#8 x 1 1/4" Screw	86	1	Left Handrail Assembly
37	1	Console	87	1	Console Base
38	1	Left Roller Cover	88	1	Console Back
39	1	Right Roller Cover	89	1	Console Base Back
40	1	Motor Belt	90	1	Chest Strap
41	1	Magnet	91	1	Chest Sensor
42	1	Drive Roller/Pulley	92	1	Right Outside Cover
43	2	Belt Guide	93	1	Right Handrail Assembly
44	1	Walking Platform	94	1	Right Inside Cover
45	1	Rear Cover	95	0	Not Used
46	4	Incline Motor Bushing	96	2	Console Fan
47	1	Idler Roller	97	1	Ground Wire
48	1	Walking Belt	98	2	Handrail Cap
49	1	Front Hood	99	4	#8 x 3/8" Screw
50	1	Power Cord	100	6	#3 x 1/4" Screw

Key No.	Qty.	Description	Key No.	Qty.	Description
101	1	Console Crossbar	107	2	Frame Bushing
102	4	#8 x 1" Screw	108	1	Computer
103	1	Crossbar	109	1	1/4" Nut
104	2	Console Clamp	110	4	Leveling Feet
105	2	3/8" x 2 1/2" Screw	*	-	User's Manual
106	1	Left Outside Cover			

Note: Specifications are subject to change without notice. For information about ordering replacement parts, see the back cover of this manual. \*These parts are not illustrated.

# EXPLODED DRAWING A

Model No. NTL19010.2 R0212A

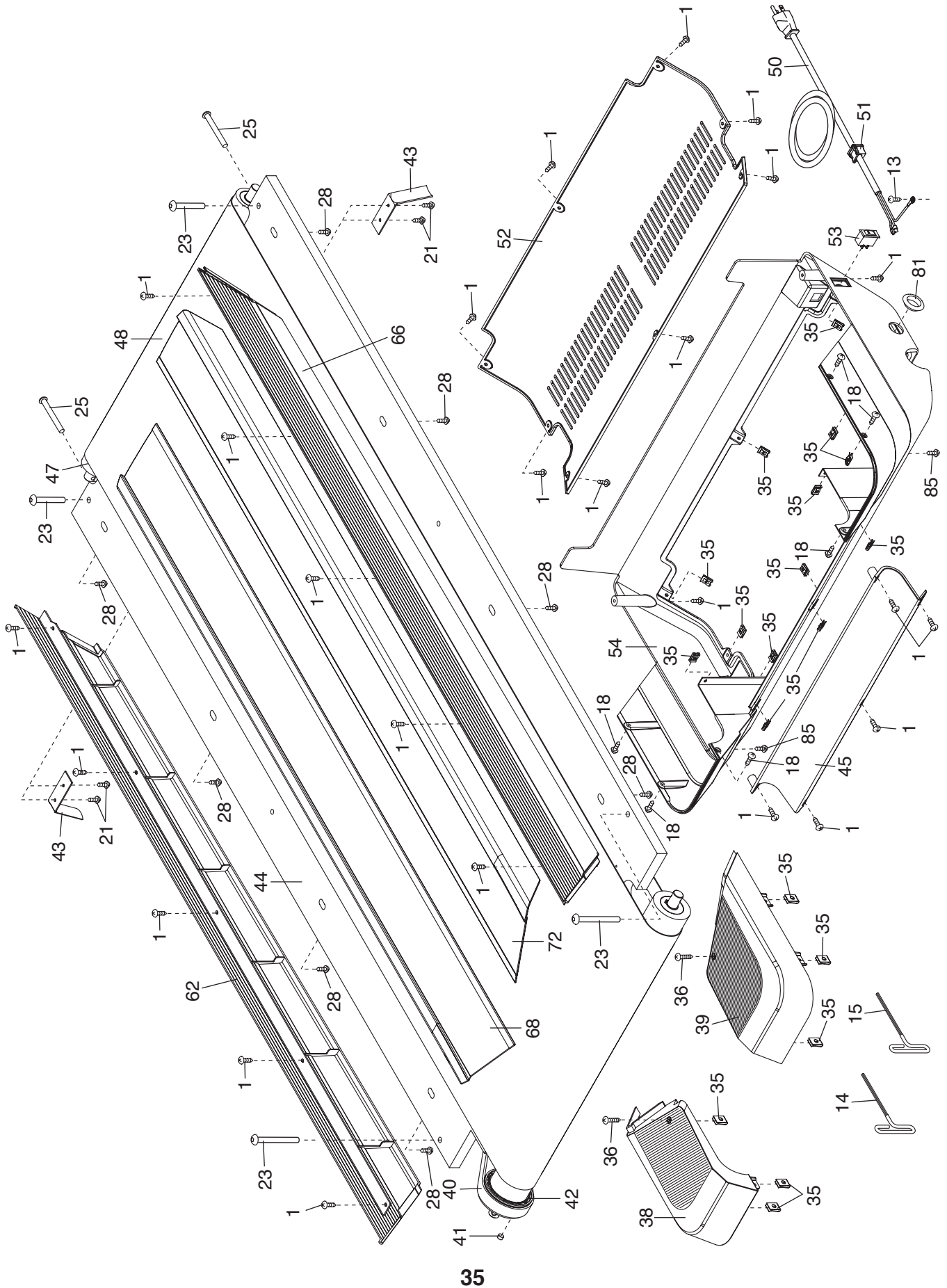

# EXPLODED DRAWING B

Model No. NTL19010.2 R0212A

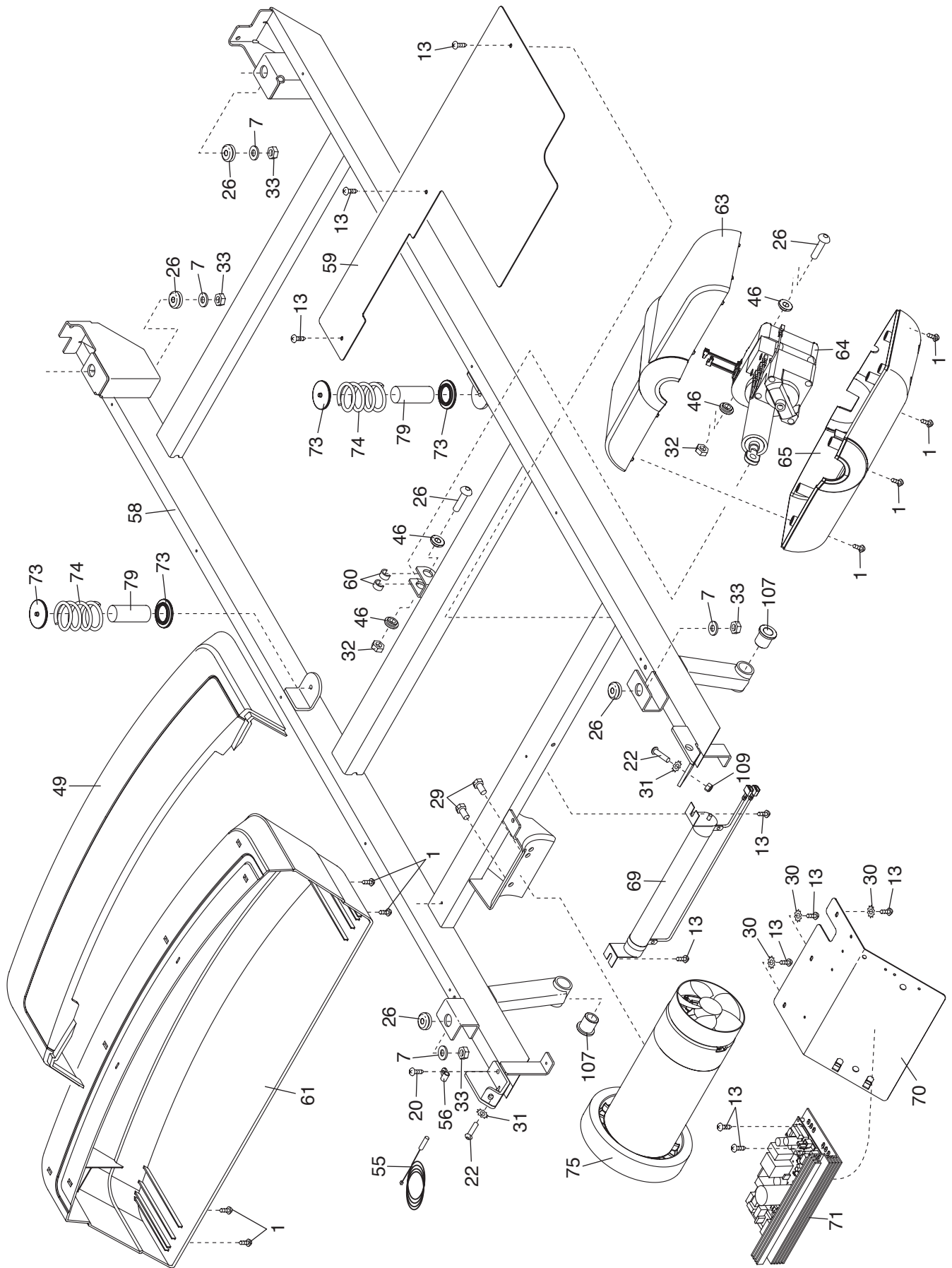

# EXPLODED DRAWING C

Model No. NTL19010.2 R0212A

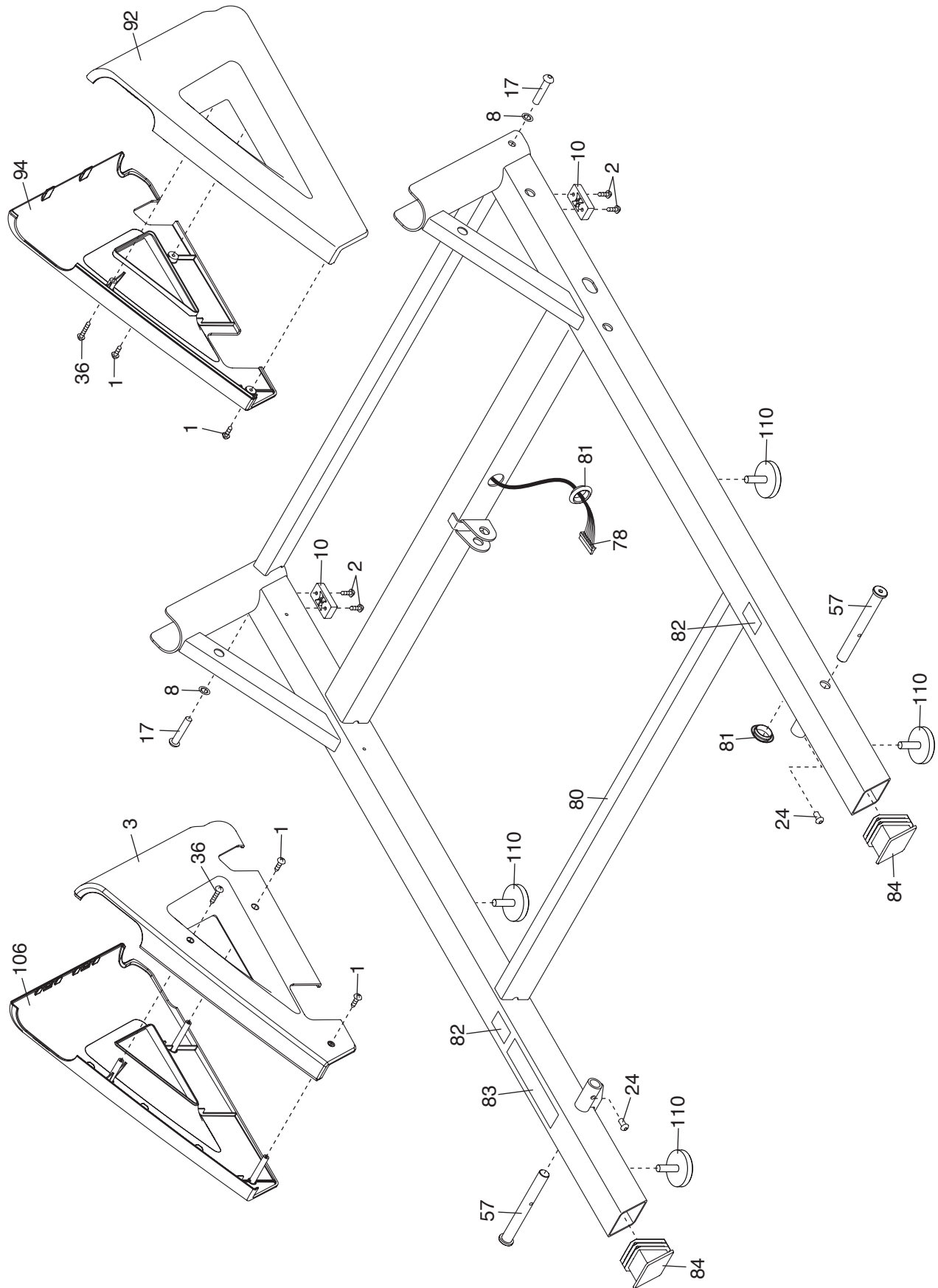

# EXPLODED DRAWING D

Model No. NTL19010.2 R0212A

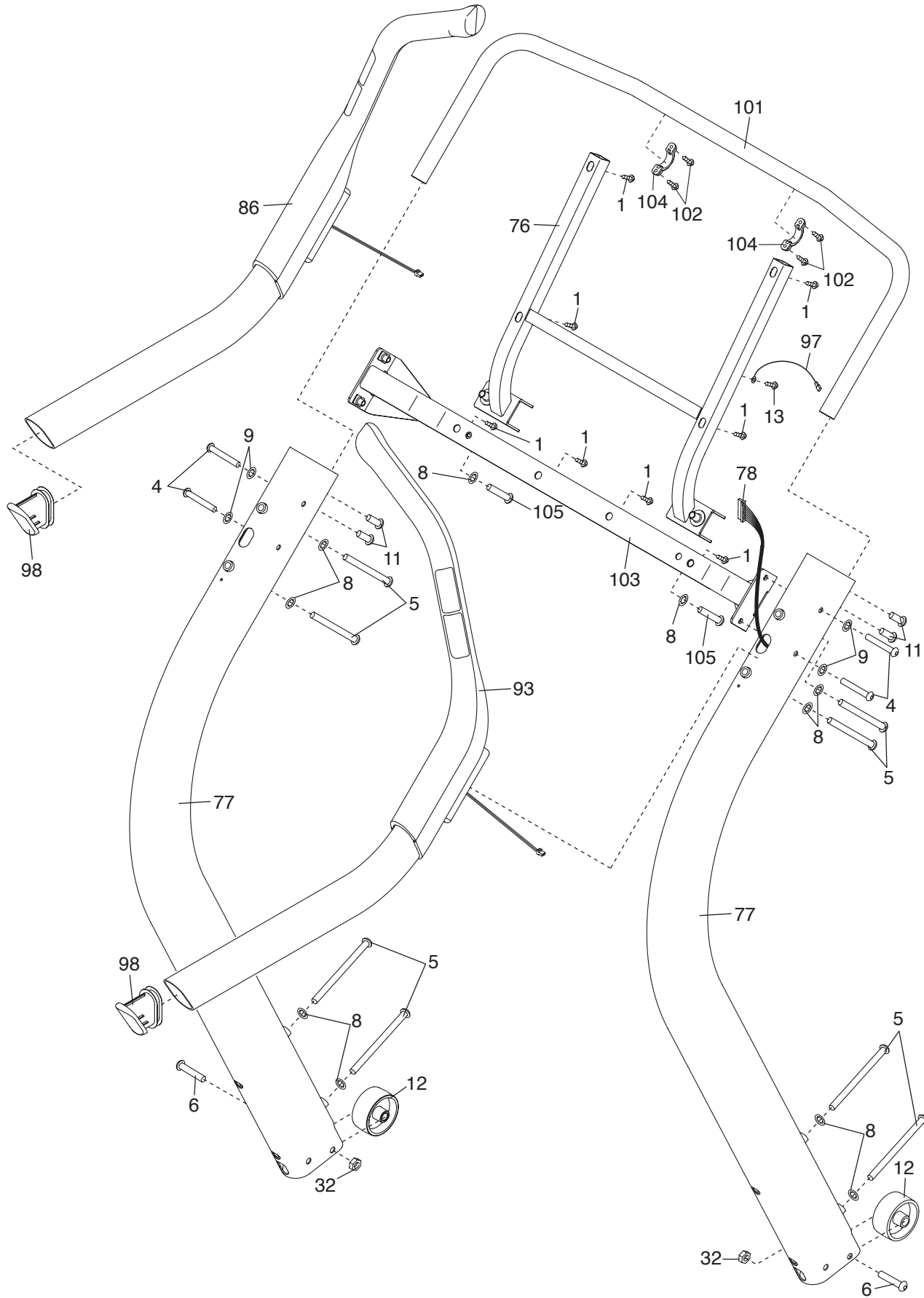

# EXPLODED DRAWING E

Model No. NTL19010.2 R0212A

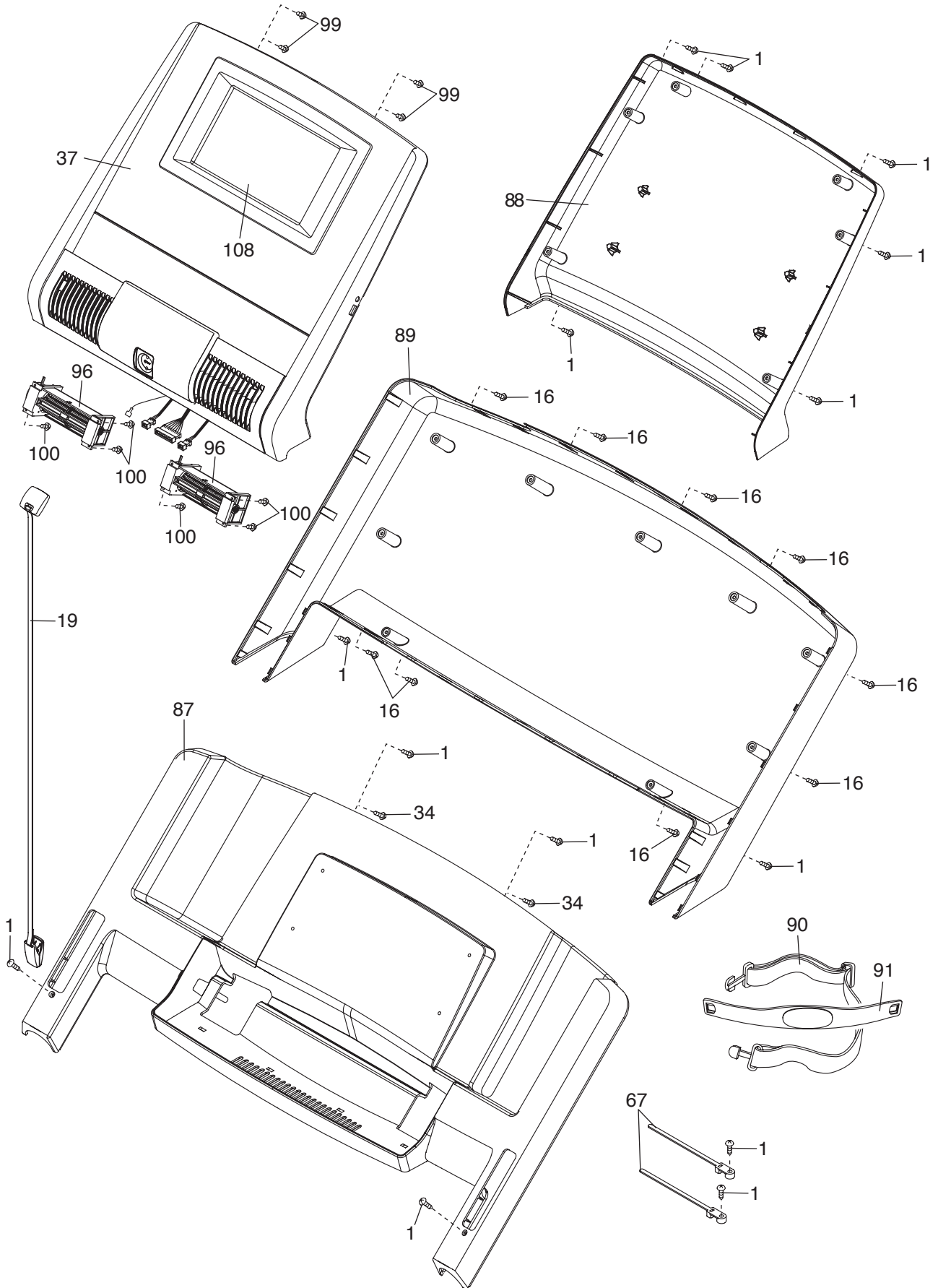

---

# ORDERING REPLACEMENT PARTS

To order replacement parts, please see the front cover of this manual. To help us assist you, be prepared to provide the following information when contacting us:

- the model number and serial number of the product (see the front cover of this manual)
- the name of the product (see the front cover of this manual)
- the key number and description of the replacement part(s) (see the PART LIST and the EXPLODED DRAWING near the end of this manual)

## LIMITED WARRANTY

**IMPORTANT: You must register this product within 30 days of the purchase date to avoid added fees for service needed under warranty. Go to [www.nordictrackservice.com/registration](http://www.nordictrackservice.com/registration).**

ICON Health & Fitness, Inc. (ICON) warrants this product to be free from defects in workmanship and material, under normal use and service conditions. The frame and drive motor are warranted for a lifetime. Parts are warranted for five (5) years from the date of purchase. Labor is warranted for two (2) years from the date of purchase.

This warranty extends only to the original purchaser (customer). ICON's obligation under this warranty is limited to repairing or replacing, at ICON's option, the product through one of its authorized service centers. All repairs for which warranty claims are made must be preauthorized by ICON. If the product is shipped to a service center, freight charges to and from the service center will be the customer's responsibility. If replacement parts are shipped while the product is under warranty, the customer will be responsible for a minimal handling charge. For in-home service, the customer will be responsible for a minimal trip charge. This warranty does not extend to freight damage to the product. This warranty will automatically be voided if the product is used as a store display model, if the product is purchased or transported outside the USA, if all instructions in this manual are not followed, if the product is abused or improperly or abnormally used, or if the product is used for commercial or rental purposes. No other warranty beyond that specifically set forth above is authorized by ICON.

ICON is not responsible or liable for indirect, special, or consequential damages arising out of or in connection with the use or performance of the product; damages with respect to any economic loss, loss of property, loss of revenues or profits, loss of enjoyment or use, or costs of removal or installation; or other consequential damages of any kind. Some states do not allow the exclusion or limitation of incidental or consequential damages. Accordingly, the above limitation may not apply to the customer.

The warranty extended hereunder is in lieu of any and all other warranties, and any implied warranties of merchantability or fitness for a particular purpose are limited in their scope and duration to the terms set forth herein. Some states do not allow limitations on how long an implied warranty lasts. Accordingly, the above limitation may not apply to the customer.

This warranty provides specific legal rights; the customer may have other rights that vary from state to state.

**ICON Health & Fitness, Inc., 1500 S. 1000 W., Logan, UT 84321-9813**