



SCHWINN[®] FITNESS

©2007. Nautilus, Inc. All rights reserved. Nautilus, the Nautilus Logo, Universal, the Universal Logo, Bowflex, StairMaster, Pearl Izumi and Nautilus Institute are either registered trademarks or trademarks of Nautilus, Inc. Schwinn is a registered trademark. All other trademarks are owned by their respective companies. Nautilus, Inc., World Headquarters, 16400 SE Nautilus Drive, Vancouver, WA 98683 1-800-NAUTILUS www.nautilus.com

Nautilus[®] Bowflex[®] Schwinn[®] Fitness Pearl Izumi[®] StairMaster[®] Universal[®] Nautilus Institute[®]

SCHWINN® FITNESS

Schwinn® IC Bikes

IC Elite, IC Pro, IC Evolution, IC Evolution SR



Service Manual



Table of Contents

Important Safety Warnings	4
Recommended Tools and Lubes	5
Reading the Serial Number	6
Basic Troubleshooting	7
Replacement Part Instructions	11
Preventative Maintenance	12
Important Contact Numbers	14

Important Safety Warnings

 This icon means a potentially hazardous situation which, if not avoided, could result in death or serious injury. Failure to follow these precautions can cause damage to the Schwinn® IC Bike series, serious injury to users and bystanders, and can also compromise the effectiveness of your exercise program.

Before using this equipment, obey the following warnings:

 Read and understand the complete Owner's Manual.
Read and understand all Warnings on this machine.

1. Keep children away from this machine and / or supervise them closely if they are near the machine or present during its operation. This machine is not suitable as a children's toy. There is a natural tendency for children to want to play on exercise equipment and parents and other in charge of children should be aware of their respective responsibilities. Moving parts that may appear to present obvious hazards to adults may not appear to do so to children.
2. Consult a physician prior to commencing an exercise program. If, at any time, you feel faint or dizzy, or experience pain, stop and consult your physician.
3. Inspect this machine for loose parts or signs of wear. Pay special attention to the Seat, Pedals, and Crank Arms. Do not use if found in this condition; contact Nautilus Customer Service.
4. Set up and operate this exercise machine on a solid level surface.
5. This machine contains moving parts. Use Caution. Do not wear loose clothing or jewelry.
6. This machine is designed for a User's Weight Limit of 300 pounds (136) kilograms. Do not use if you are over this weight.
7. Set up the machine so that there is a free area of 19.7 inches (0.5 m) on all sides of the machine. Keep third parties out of this area when the machine is in use.
8. Operate the machine in the manner described in this manual. It can be hazardous to over-exert yourself during exercise
9. Make sure that all positional adjustment devices are securely engaged.

Recommended Tools and Lubes

We recommend the following tools and lubes to properly assemble, maintain and repair all Schwinn® Indoor Cycling bikes.

Tools

1. Torque wrench w/ 8mm Allen Key socket: used to tighten the crank bolts of crank arms to 480 lbf/in.
2. Pedal wrench: Has 15mm and 9/16" wrench to tighten and loosen pedals.
3. Crank puller: needed to take off right and left crank arms.
4. ISIS Insert Plug for Crank Puller, M12 x 1.0
5. Bottom bracket tool for ISIS Overdrive BB. used to take out bottom bracket from frame.
6. Adjustable wrench: used to tighten or loosen the pop pin assembly from frame.
7. 17mm wrench: used to adjust the inside axle nuts closest to the flywheel bearings.
8. 15mm wrench: used to loosen the outside axle nut on each side of the flywheel bearings.
9. 14mm wrench: used to tighten the nuts of the seat bracket.
10. 13mm wrench: needed during assembly for the front and back stabilizers nuts and bolts.
11. 11mm wrench: used to tighten the larger bolt of the brake assembly.
12. 10mm wrench: used to adjust chain tensioner bolts during chain tightening, transport wheel nut and bolt and front nut of the resistance assembly when centering brake pads.
13. 8mm wrench: goes to the smaller resistance knob nylon nut (older models) and smaller brake assembly bolt.
14. 7mm wrench: used to loosen guide rod nut when replacing guide rod springs.
15. 5mm Allen wrench: used to tighten the bolts on Evolution stabilizers.
16. 4mm Allen wrench: used to loosen the bolt of the brake pads and the Allen chain guard screws (newer models).
17. 3mm Allen wrench: used for the screws of the water bottle cages.
18. Smart Release™ adjusting tool: high quality tool specifically designed for use with the new adjustable Smart Release™ mechanism. (SR Models only).

Lubes

1. Schwinn® Fit-Tech Silicone Spray: recommended for the brake pads and all moving parts (e.g., handle bar post, seat post & slide, pop-pins, resistance knob etc.)
2. Schwinn® Equipment Polish: recommended on a damp cloth when wiping down the frame after use.
3. Schwinn® Citrus Chain Wax: recommend to lubricate the chain through the rear hole in the chain guard as the flywheel is rotating.
4. Schwinn® Quick Shot: recommended for the threads of stabilizer bolts and pedals before tightening to crank arms.

Reading the Serial Number

Find the serial number on the underside of the machine base. Decode the information in the serial number with the below instructions:

AAABCCCCC

AAA= Day of the year manufactured (e.g., 35 = February 4th)

B= Last digit of year manufactured (e.g., 6 = 2006)

CCCCC = Unique code for each individual unit.

Serial number tags on newer models also read date of manufacture.



Serial Number

Basic Troubleshooting

Problem: Loud Squealing Sound From the Brake

Solution:

- A. Use a 4mm Allen wrench to remove the bolt and spring from the brake assembly. (See Figure 1.)
- B. Slide the brake pads out of the assembly.
- C. Rough up the surface with a wire brush if the pads look glossy.
- D. Saturate the brake pads with silicone lubricant after they have been roughed up.
- E. Replace the brake pads.
- F. Tighten the bolt and spring to the pads only finger-tight. This gives the brake pads a longer life.

Figure 1

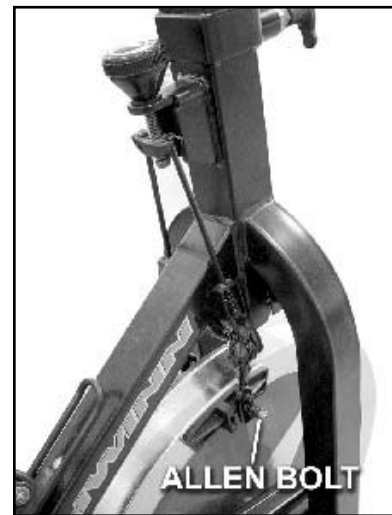

Problem: Brake Pads are too Tight on Minimum Resistance

Solution: Turn the resistance knob all the way to the right (maximum resistance) and let it sit for two hours. This compresses the guide rod springs allowing space between the pads and the flywheel. (See Figure 2.)

Figure 2



Basic Troubleshooting

Problem: Brake Pads Off Center

Solution:

- A. Use a 10mm wrench to loosen the nylon nut on the front of the bike.
- B. Adjust the brake assembly until the brake pads are evenly spaced from the flywheel.
- C. Tighten the nylon nut using moderate torque.

Figure 3



Problem: Chain is too Loose

Solution:

- A. Use a 15mm wrench or socket to loosen each axle nut of the flywheel.
- B. Use a 10mm wrench and turn each chain tensioner bolt 1/4 turn to the right.
- C. Get on the bike and check for any play in the chain by rocking back and forth on the pedals.
- D. Tighten the axle nuts on the flywheel once the pedals and the flywheel are moving as one.

NOTE: Make sure that the flywheel aligns with the frame.

Figure 4

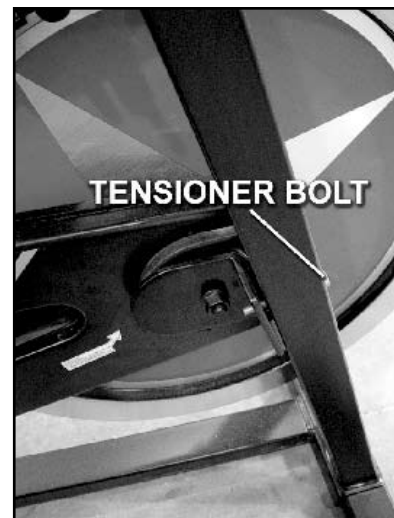

Basic Troubleshooting

Problem: Chain Makes a Grinding Sound

Solution: Chain too tight and/or the flywheel out of alignment.

- A. Use a 15mm wrench to loosen each axle nut.
- B. Adjust the 10mm chain tensioner bolts to align the flywheel with the frame. Make sure that the chain tension is adjusted properly without being too tight.
- C. Adjust the chain tension by locating the point where the chain is tightest during one revolution of the crank.
- D. Check the tension. You should be able to move the chain up and down about 3/8" (in either direction).
- E. Lubricate the chain.
- F. Take the bike for a test ride.

Problem: Bike is Wobbling or Uneven While Riding

Solution:

- A. Check the foot levelers on the bottom of the stabilizers.
- B. Adjust the levelers and the bike until it is square on the floor.
- C. Secure the leveler nuts to prevent them from loosening. (See Figure 5.)

Figure 5

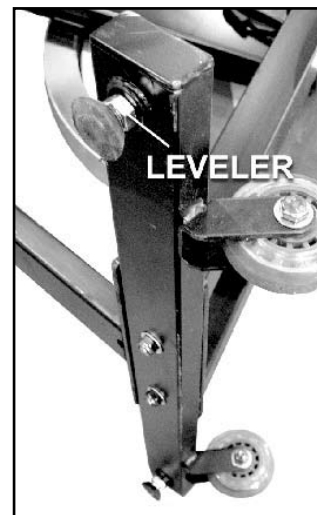

Basic Troubleshooting

Problem: Crank Arms or Pedals Feel Loose

Solution:

- A. Make sure the pedals are tightly screwed into the crank arms. (See Figure 6.)
- B. Make sure the crank bolts on both crank arms are tight.
- C. Make sure the square opening in the crank arms have not been rounded out. This problem is caused when the bike has been ridden with loose arms. Replace the crank arm if the square taper shows damage.
- D. Make sure the bottom bracket is tight in the frame and bearings operate smoothly.

Figure 6



Problem: Handlebar or Seat Post is too Tight

Solution:

- A. Clean and lubricate the handlebar/seat post extension tube and frame sleeves with silicone lube.
- B. If fit remains tight, switch the handlebar or seat post with one from another bike.
- C. If this does not fix the problem order a new sleeve.

Replacing Parts

IC Pro and IC Elite Brake Rod and Knob Replacement

Tools Required:

- #2 Phillips or Flat Head Screwdriver
- 10mm Box Wrench or Small Adjustable Wrench
- 7mm Box Wrench or Small Adjustable Wrench

Procedure:

A. Replace the Tension Control Knob

1. Turn the tension control knob to least resistance.
2. Use a flat or phillips head screwdriver to remove the shrouds. (See Figure 7.)
3. Remove the brake rods from the rod carrier by holding the rod tightly and lifting up and out of the carrier. (See Figure 8.)
4. Use a wrench to remove the 10mm nut on the end of the tension control knob.
5. Remove the square nut and rod carrier from the tension control knob.
6. Remove the tension control knob and replace with the new longer control knob. (See Figure 9.)
7. Replace the rod carrier, square nut and 10mm nut. Secure tightly. (See Figure 10.)

B. Replace the Brake Rods

1. Invert the brake rod and use a wrench to remove the 7mm nut on the end of the rod.
2. Remove the rods, springs, and rubber grommets and replace with new shorter rods, springs and rubber grommets.

Figure 7



Figure 8

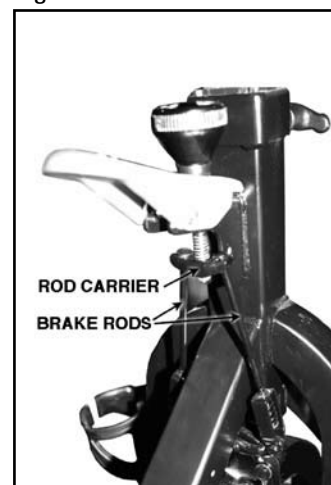

Figure 9

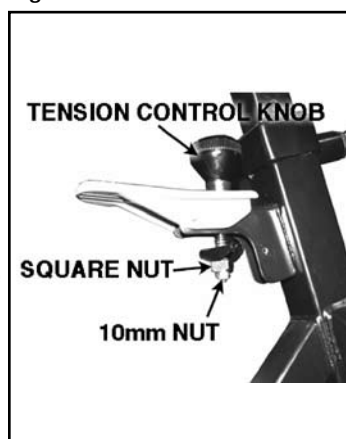



Figure 10



Preventative Maintenance

Attention: Any Schwinn® bike that is allowed to operate with torque in excess of the specified values does not qualify for warranty replacement for the crank arms.

 Do NOT torque crank bolts in excess of 360 obf/in. on IC Pro and IC Elite or 420 lbf/in on Evolution models. Overtightening causes damage to the crank or the bottom bracket interface.

Daily Maintenance

At the end of each workout:

- Release the brake resistance so that the brake pads do not contact the flywheel.
- Clean the bike with Schwinn® equipment polish and a clean damp cloth.
- Remove the handlebars from the head tube to allow the handlebar tube and sleeve to dry.
- Release the brake resistance so that the brake pads do not contact the flywheel.

Weekly Maintenance

Inspect the Schwinn® Indoor Cycling bike for loose parts, nuts, bolts, etc. Pay special attention to the brake assembly, seat and handlebar pop-pins. This will prolong the service life of the product.

Monthly Maintenance

- Check the chain for proper adjustment.
- Move the crank arms back and forth. If there is more than 1/4" movement in the chain before the flywheel turns, tighten the chain (See page 9).
NOTE: Make sure you adjust both sides equally so that the flywheel remains in alignment with the frame.
- Check the crank bolts with a torque wrench. The torque should not exceed 360 lbf/in for IC PRO and IC ELITE and 420 lbf/in for the EVOLUTION models.
- Check that both pedals are secured and properly attached to the crank arms.
NOTE: Only trained personnel should change the pedals. Unqualified people performing this procedure can cause threads to cross. Crossed threads do not qualify for warranty replacement.
- Make sure handlebar and seat pop-pins are fully tightened and operating smoothly.

 Use extreme care when servicing the Schwinn® Indoor cycling bike with the chain guard removed. If your fingers or other parts of the the body come into contact with moving parts inside the bike, amputation or other serious injury may occur. Before starting any maintenance on the chain drive, familiarize yourself with all moving parts. Never leave a Schwinn® bike unattended with the chain guard removed.

Preventative Maintenance

Adjust the Smart Release™ Mechanism

Tools:

- Smart Release™ Adjusting tool
- 45 to 50 lb. dumbbell or weight

Attention: Only a mechanic trained to work on Schwinn® IC bicycles should do this procedure. Make adjustments to the Smart Release™ mechanism only to restore the mechanism to factory specifications. Never overtighten.

Procedure:

1. Ride the bike. This forces the the Smart Release™ mechanism to break free. Pedal up to a moderate speed with little or no resistance on the flywheel while applying enough back pressure to the cranks to release the mechanism. Repeat this several times to ensure that the mechanism is up to operating temperature and to feel the initial setting.
2. From the front of the bike, insert the Smart Release™ adjusting tool into the space between the chain guard and the flywheel.
3. Rotate the flywheel until the 7mm diameter hole in the Smart Release™ adjusting plate is visible from the front of the bike.
4. Tighten the resistance mechanism to prevent the flywheel from rotating.
5. Place a 45 or 50 lb. dumbbell or weight on the right side pedal (chain guard side) with the crank in the 9 o'clock position.

Note: When properly adjusted, the Smart Release™ mechanism should break free allowing the crank arm to rotate down under this amount of weight.

6. Insert the Smart Release™ Adjusting Tool so that the bend in the tool corresponds to the shape of the flywheel. (See Figure 12.)
7. Insert the pin of the tool into the hole of the Smart Release™ adjusting plate.
8. Pull the handle of the tool UP toward the top of the flywheel to increase the release pressure (higher breakaway force) and DOWN to decrease the release pressure (lower breakaway force). (See Figure 13.)
9. Ride the bike to test that the factory specified resistance has been achieved.

Figure 11

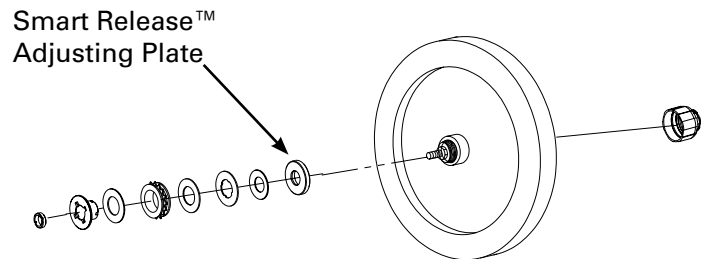

Figure 12

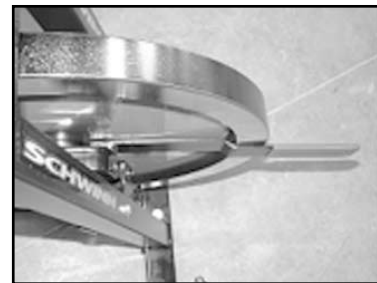
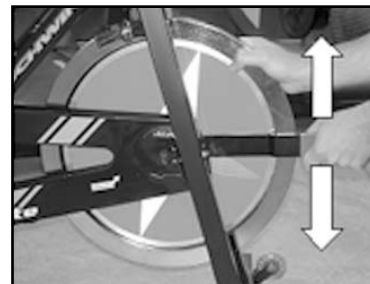

Figure 13



Important Contact Numbers

OFFICES IN THE UNITED STATES:

E-mail: customerservice@nautilus.com

TECHNICAL/CUSTOMER SERVICE

Phone: 800-NAUTILUS (800-628-8458)

Fax: (877) 686-6466

E-mail: cstech@nautilus.com

CORPORATE HEADQUARTERS

Nautilus, Inc.

World Headquarters

16400 SE Nautilus Drive

Vancouver, Washington, USA 98683

Phone: (800) NAUTILUS (800) 628-8458

INTERNATIONAL OFFICES:

For technical assistance and a list of distributors in your area, please call or fax one of the following numbers.

INTERNATIONAL CUSTOMER SERVICE

Nautilus International S.A.

Rue Jean Prouvé

1762 Givisiez / Switzerland

Tel: (41) (26) 460 77 77

Fax: (41) (26) 460 77 70

E-mail: technics@nautilus.com

GERMANY and AUSTRIA

Nautilus Deutschland GmbH

Albin-Köbis-Str. 4

51147 Köln

Tel.: (49) 02203 2020 0

Fax: (49) 02203 2020 45 45

ITALY

Nautilus Italy S.r.l., Via della Mercanzia, 103

40050 Funo di Argelato - Bologna

Tel: (39) 051 664 6201

Fax: (39) 051 664 7461

SWITZERLAND

Nautilus Switzerland SA

Rue Jean-Prouvé 6,

CH-1762 Givisiez

Tel: (41) 026 460 77 66

Fax: (41) 026 460 77 60

UNITED KINGDOM

Nautilus UK Ltd

Nautilus UK, 4 Vincent Avenue,

Crownhill, Milton Keynes, Bucks, MK8 0AB

Tel: (44) 1908 267 345

Fax: (44) 1908 567 346

CHINA

Nautilus Representative Office

Nautilus, Shanghai, 7A No.728, Yan'an Rd(West)

200050 Shanghai, China

Tel: (86) 21 523 707 00

Fax: (86) 21 523 707 09